

101, Rev. D 70-m Subnet Telecommunications Interfaces

Released: April 21, 2011

Document Owner:

Stephen D. Slobin 4-11-2011
Stephen D. Slobin Date
Antenna System Engineer

Approved by:

 4/12/11
Timothy T. Pham Date
DSN Communication System Chief Engineer

Released by:

Signature on file at DSN Library 4/21/2011
DSN Document Release Date

Change Log

Rev	Issue Date	Prepared By	Paragraphs Affected	Change Summary
Initial	1/15/2001	Stephen Slobin Robert Sniffin	All	
A	07/30/2003	Stephen Slobin Robert Sniffin	All	Revised gain and noise temperature reference point to feedhorn aperture. Documented installation of new feedcone at DSS 63. Provided diagrams of L-band microwave equipment and Low-noise S-band cone at DSS 43.
Chg 1	03/31/2004	Stephen Slobin Robert Sniffin	Figures 1, 5	Corrected S-band amplifier types in Figure 1. Replaced Figure 5 with correct graphic
B	8/25/2006	Stephen Slobin Robert Sniffin	All	Documents removal of DSS-43 Ultracone. Revised T_{AMW} formulation for noise temperature to be consistent with Rev. B of module 105.
C	9/15/2009	Stephen Slobin Robert Sniffin	Pages 1, 6, Table 1, Figure 1.	Replaced DSMS with DSN. Correctly stated that 400-kW S-band uplink is available at DSS-43 only. Included frequency range for support for this capability. DSS-14 S-band radar transmitter removed.
D	4/21/2011	Stephen Slobin Christine Chang	Tables 2, 4, 5, 6, A-3. Figures 1, 8, 9, 10.	S-band maser at DSS-14 replaced with a HEMT. 1.8 K higher noise temperature with HEMT. LNA numbering updated.

Contents

<u>Paragraph</u>	<u>Page</u>
1 Introduction.....	5
1.1 Purpose.....	5
1.2 Scope.....	5
2 General Information	5
3 Telecommunications Parameters	6
3.1 Antenna Gain.....	7
3.1.1 Frequency Effects.....	7
3.1.2 Elevation Angle Effects.....	7
3.1.3 Wind Loading	8
3.2 System Noise Temperature	8
3.3 Pointing	10
Appendix A Equations for Modeling.....	37
A.1 Equations for Gain Versus Elevation Angle	37
A.2 Equations for System Noise Temperature Versus Elevation Angle.....	37
A.3 Equation for Gain Reduction Versus Pointing Error.....	39

Illustrations

<u>Figure</u>	<u>Page</u>
Figure 1. Functional Block Diagram of S-Band and X-Band Microwave and Transmitter Equipment.....	28
Figure 2. Functional Block Diagram of L-Band Microwave Equipment	29
Figure 3. S-Band Receive Gain, All Stations, at Feedhorn Aperture	30
Figure 4. X-Band Receive Gain, DSS 14 Antenna, X-Only Configuration (S/X Dichroic Retracted), at Feedhorn Aperture.....	30
Figure 5. X-Band Receive Gain, DSS 43 Antenna, X-Only Configuration (S/X Dichroic Retracted), at Feedhorn Aperture.....	31
Figure 6. X-Band Receive Gain, DSS 63 Antenna, X-Only Configuration (S/X Dichroic Retracted), at Feedhorn Aperture.....	31
Figure 7. L-Band System Noise Temperature, All Stations, at Feedhorn Aperture	32
Figure 8. S-Band System Noise Temperature, DSS 14 Antenna, LNA-1, Non-Diplexed, at Feedhorn Aperture.....	32
Figure 9. Eastern Horizon S-Band System Noise Temperature at 6° Elevation Angle.....	33
Figure 10. Western Horizon S-Band System Noise Temperature at 6° Elevation Angle.....	33
Figure 11. X-Band System Noise Temperature, DSS 14 Antenna, LNA-1 or LNA-2, X-Only Configuration (S/X Dichroic Retracted).....	34

Figure 12. X-Band System Noise Temperature, DSS 43 Antenna, LNA-1 or LNA-2, X-Only Configuration (S/X Dichroic Retracted)..... 34
 Figure 13. X-Band System Noise Temperature, DSS 63 Antenna, LNA-1 or LNA-2, X-Only Configuration (S/X Dichroic Retracted)..... 35
 Figure 14. L-Band and S-Band Pointing Loss Versus Pointing Error 35
 Figure 15. X-Band Pointing Loss Versus Pointing Error..... 36

Tables

<u>Table</u>	<u>Page</u>
Table 1. S- and X-Band Transmit Characteristics	11
Table 2. L-, S-, and X-Band Receive Characteristics	16
Table 3. Gain Reduction Due to Wind Loading, 70-m Antenna	20
Table 4. T_{AMW} , T_{sky} , and T_{op} for CD=25% Average Clear Weather at Zenith, Referenced to Feedhorn Aperture.....	20
Table 5. DSS 14 Eastern Horizon S-Band T_{op} (K) with SPD Cone	22
Table 6. DSS 14 Western Horizon S-Band T_{op} (K) with SPD Cone	23
Table 7. DSS 43 Eastern Horizon S-Band T_{op} (K) with SPD Cone	24
Table 8. DSS 43 Western Horizon S-Band T_{op} (K) with SPD Cone	25
Table 9. DSS 63 Eastern Horizon S-Band T_{op} (K) with SPD Cone	26
Table 10. DSS 63 Western Horizon S-Band T_{op} (K) with SPD Cone	27
Table A-1. Vacuum Component of Gain Parameters, Referenced to Feedhorn Aperture.....	40
Table A-2. Zenith Year-Average Atmosphere Attenuation Above Vacuum (A_{ZEN})	40
Table A-3. Antenna-Microwave Noise Temperature Parameters, Referenced to Feedhorn Aperture	41

1 Introduction

1.1 Purpose

This module provides the performance parameters for the Deep Space Network (DSN) 70-meter antennas that are necessary to perform the nominal design of a telecommunications link. It also summarizes the capabilities of these antennas for mission planning purposes and for comparison with other ground station antennas.

1.2 Scope

The scope of this module is limited to providing those parameters that characterize the RF performance of the 70-meter antennas. The parameters do not include effects of weather, such as reduction of system gain and increase in system noise temperature, that are common to all antenna types. These are discussed in Module 105, Atmospheric and Environmental Effects. This module also does not discuss mechanical restrictions on antenna performance that are covered in Module 302, Antenna Positioning, or the effects of terrain masking that are covered in Module 301, Coverage and Geometry.

2 General Information

The DSN 70-m Antenna Subnet contains three 70-meter diameter antennas. Deep Space Station (DSS) 14 is located at Goldstone, California, DSS-43 is near Canberra, Australia, and DSS-63 is near Madrid, Spain. The precise station locations are shown in Module 301, Coverage and Geometry. All antennas support L-, S-, and X-band reception, and S-band and X-band transmission.

Figure 1 is a block diagram of the S-band and X-band microwave and transmitter equipment at DSS-14, DSS-43, and DSS-63 that is common to all three stations. A block diagram of the L-band equipment at the three stations is shown in Figure 2.

For S-band, the stations utilize the S-band Polarization Diversity (SPD) feedcone that contains the feed, the primary low-noise amplifier (LNA) and its support equipment, the diplexer, and the required switches and other waveguide. The backup LNA and the S-band transmitters are located in an area beneath the feedcones referred to as the Module III area. The S-band feed employs an orthomode junction that permits simultaneous right hand circular polarization (RCP) and left hand circular polarization (LCP) to be used. The polarizer may be switched so that either polarization may be directed to the non-diplexed path with the opposite polarization appearing on the diplexed path. The lower-noise non-diplexed path (orthomode upper arm) is used for listen-only reception, or if the spacecraft transmits and receives on opposite polarizations. If the spacecraft receives and transmits simultaneously with the same polarization, the diplexed path must be used for reception and the noise temperature is higher. A 20-kW S-band transmitter is provided for normal spacecraft communication at all three sites. An additional 400-kW S-band transmitter is available at DSS-43 for emergency commanding.

Prior to September, 2010, the S-band LNA in the SPD cone at all stations was a maser, and the LNA in the Module III area was a HEMT. In September, 2010, a new S-band HEMT was installed at DSS-14, replacing the existing S-band maser. This will retain the existing designation of LNA-1. The noise temperature using this new LNA is increased by about 1.8 K, as shown in Tables 2, 4, 5, 6, and A-3, and in Figures 8, 9, and 10. Implementation dates for new S-band HEMTs at DSS-43 and DSS-63 are not presently known, but will be some time in the 2013-2015 time period.

All three 70-meter antennas employ the X-band Transmit-Receive feedcone (the XTR cone). The XTR cone employs a unique feed design that includes a diplexing junction to inject the transmitted signal directly into the feed. This eliminates the need for a waveguide diplexer and a common path for the received and transmitted signals. As a result, much of the received path can be cryogenically cooled with a significant reduction in operating system temperature. The S/X dichroic plate can also be retracted when S-band is not required for a further improvement in X-band performance – lower noise temperature and higher gain. When the S/X dichroic is retracted, both the X-band transmit and receive beams are moved to the left (looking outward from the antenna, minus cross-elevation direction, smaller azimuth) about 8.5 mdeg relative to the X-band beam in the S/X configuration. This beam movement is corrected for by existing pointing models, however the appropriate model must be chosen by an operator prior to observing a spacecraft. The XTR feed includes a fixed circular polarizer and an orthomode junction to enable both circular polarizations to be received simultaneously. Each polarization is routed to one of two identical high-electron-mobility transistor (HEMT) low-noise amplifiers located within the cryogenic package. A separate, switchable polarizer is provided for the X-band transmitter so that the transmitted signal can be of either polarization

The 70-m antennas are equipped with an L-band feed (Figure 2) mounted on the outside of the XTR cone. The feed normally receives LCP, but could be disassembled and reconfigured to receive RCP. The low noise amplifiers, an L-band to S-band upconverter for the received signal, and an S-band to L-band downconverter for test signals are located in the Module III area. The output of the L-band to S-band upconverter is substituted for one of the two S-band receive channels. However, the need to position the antenna subreflector to illuminate the L-band feed prevents the other frequencies from being simultaneously available.

The L-, S- and X-band feeds are provided with phase calibration couplers and comb generators so the stations can be used for very-long baseline interferometry reception in addition to spacecraft tracking.

The Goldstone site also has an X-band radar transmitter (Goldstone Solar System Radar, GSSR) in a third cone that operates near the normal receive frequency band. In this third cone is also a Ku-band (22 GHz) receive feed for radio astronomy investigations. The third feedcone position at DSS 43 is now occupied with host-country equipment for non-DSN use. At DSS-63, a third feedcone has been installed that contains a Ku-band radio astronomy feed.

3 *Telecommunications Parameters*

The significant parameters of the 70-meter antennas that influence telecommunications link design are listed in Tables 1 and 2. Variations in these parameters that

are inherent in the design of the antennas are discussed below. Other factors that degrade link performance are discussed in Modules 105 (Atmospheric and Environmental Effects) and 106 (Solar Corona and Wind Effects).

3.1 *Antenna Gain*

The antenna gains in Tables 1 and 2 do not include the effect of atmospheric attenuation and should be regarded as vacuum gain referenced to the feedhorn aperture.

3.1.1 *Frequency Effects*

Antenna gains are specified at the indicated frequency (f_0). For operation at higher frequencies in the same band, the gain (dBi) must be increased by $20 \log (f/f_0)$. For operation at lower frequencies in the same band, the gain must be reduced by $20 \log (f/f_0)$.

3.1.2 *Elevation Angle Effects*

Structural deformation causes a reduction in gain when the antenna operates at an elevation angle other than the angle where the reflector panels were aligned. The net gain of the antenna is also reduced by atmospheric attenuation that is a function of elevation angle and weather condition. These effects are illustrated in Figures 3 through 6 which show the estimated gain versus elevation angle for the hypothetical vacuum condition (structural deformation only) and with 0%, 50%, and 90% weather conditions, designated as CD (cumulative distribution) = 0.00, 0.50, and 0.90. A CD of 0.00 (0%) means the minimum weather effect (exceeded 100% of the time). A CD of 0.90 (90%) means that effect which is exceeded only 10% of the time. Qualitatively, a CD of 0.00 corresponds to the driest, lowest-loss condition of the atmosphere; a CD of 0.50 corresponds to humid or very light clouds; and 0.90 corresponds to very cloudy, but with no rain. A CD of 0.25 corresponds to average clear weather. Comprehensive S-band and X-band weather effects models (for weather conditions up to 99% cumulative distribution) are provided in Module 105 for detailed design control table use.

Figure 3 depicts the S-band (2295 MHz) net gains for all stations as a function of elevation angle and weather condition, including the vacuum condition. Net gain means vacuum-condition gain as reduced by atmosphere attenuation. The L-band gain curve shapes should be considered identical to the S-band curve shapes, except that they are reduced in value by the differences shown in Table 2 and Appendix Table A-1. Figures 4, 5, and 6 present the X-band (8420 MHz) net gains of the DSS-14, DSS-43, and DSS-63 antennas as a function of elevation angle and weather condition, including the vacuum condition, using the XTR feedcone with the S/X dichroic plate retracted (the X-only configuration). The equations and parameters of these curves are given in Appendix A. The models use a flat-Earth, horizontally stratified atmosphere approximation.

It should be noted in Appendix Table A-1, that the gain parameters do not vary for different S-band configurations (e.g., LNA-1 non-diplexed vs. LNA-1 diplexed), as they do in Table A-3 for the noise temperature parameters. This is due to the fact that the gain is referenced to the feedhorn aperture, and configurations “downstream” (e.g., orthomode and diplexer paths) do not affect the value of gain at the aperture. The observed differences in

antenna G/T are attributed to different values of noise temperature when G and T are referred to the feedhorn aperture. When G and T are referenced to the LNA input, both the G and T parameters vary with antenna configuration. For X-band, which is always in a fixed diplexed configuration, the S/X dichroic position in front of the feedhorn affects both the gain and noise temperature parameters at the feedhorn aperture.

Under normal operation of the antenna, the subreflector is moved in the axial (Z-direction, in-out) and lateral (Y-direction, up-down) directions several centimeters to compensate for main reflector and quadripod gravitational distortion and to maintain antenna gain at an optimum level. As the antenna moves from 6 degrees to 90 degrees in elevation, the total subreflector axial movement, relative to the quadripod, is 3.744 cm. The subreflector movement alone contributes a phase change of -666 degrees at X-band. (The sign convention is that a longer path length results in a smaller value of phase). Quadripod distortion contributes +195 degrees, and main reflector distortion contributes -172 degrees. The net effect of these three motions is a phase change of -643 degrees at X-band.

Fixing the subreflector movement at a Y/Z value appropriate for a particular elevation angle, as is done in certain very-long baseline interferometry (VLBI) and spacecraft experiments, greatly reduces the net phase change over the range of elevation angles needed to track a radio source or spacecraft. In the 6-90 degree elevation example above, the net total phase change is reduced to +23 degrees. The downside of fixing the subreflector motion is that the antenna gain will be reduced many tenths of a dB, up to 1 dB, for deviations in elevation angle of 10-20 degrees from the nominal elevation angle. These effects should be thoroughly investigated if there is any question of having adequate margin to complete the telecommunications link. Further discussion can be found in S. D. Slobin and D. A. Bathker, "DSN 70-Meter Antenna X-Band Gain, Phase, and Pointing Performance, With Particular Application for Voyager 2 Neptune Encounter," *TDA Progress Report 42-95*, pp. 237-245, July-September 1988.

3.1.3 Wind Loading

The gain reductions at S- and X-band due to wind loading are listed in Table 3. The tabular data are for structural deformation of the main reflector only and assume that the antenna is maintained on-point by conical scan (CONSCAN, discussed in Module 302) or an equivalent process. In addition to structural deformation, wind introduces a blind-pointing error that is related to the antenna elevation angle, the angle between the antenna and the wind, and the wind speed. Cumulative probability distributions of wind velocity at Goldstone are given in Module 105.

3.2 System Noise Temperature

The system operating noise temperature (T_{op}) varies as a function of elevation angle due to changes in the path length through the atmosphere and ground noise received by the sidelobe pattern of the antenna. Figures 7 through 13 show the combined effects of these factors at L-, S-, and X-bands in a hypothetical vacuum (no atmosphere) and no cosmic noise condition for selected antenna configurations and with the three weather conditions described above. The

equations and parameters for these curves are provided in Appendix A of this module. The models use a flat-Earth, horizontally stratified atmosphere approximation.

Module 101, Rev. B and later, present a new formulation for system operating noise temperature, compared with earlier revisions. The system operating noise temperature, T_{op} , consists of two parts, an *antenna-microwave component*, T_{AMW} , for the contribution of the antenna and microwave hardware only, and a *sky component*, T_{sky} , that consists of the atmosphere noise plus the cosmic microwave background noise, attenuated by the atmosphere loss. T_{AMW} is shown in Figures 7, 8, 11, 12, and 13 as “ANT-UWV”. The previous revision (Rev. A) used a term $T_{op,vacuum}$ which included the net cosmic contribution. To this was added the atmospheric noise contribution, to obtain T_{op} . In the latest revisions the system operating noise temperature is given by

$$T_{op}(\theta) = T_{AMW} + T_{sky} = [T_1 + T_2 e^{-a\theta}] + [T_{atm}(\theta) + T'_{CMB}(\theta)]$$

where

$$T_{sky} = T_{atm}(\theta) + T'_{CMB}(\theta)$$

T_1 , T_2 , and a are coefficients and exponent given in Appendix A, Table A-3

T_{atm} is the atmosphere contribution term, calculated from Module 105

T'_{CMB} is the attenuated cosmic contribution, calculated from Module 105

More details of this calculation are given in Appendix A of this module.

Figure 7 shows the L-band (1668 MHz) system noise temperature as a function of elevation angle, for all antennas, referenced to the feedhorn aperture. Figure 8 shows the S-band (2295 MHz) system noise temperature curves for DSS 14, LNA-1, non-diplexed, referenced to the feedhorn aperture. S-band curves for other antennas and configurations can be calculated by using the parameters given in Appendix A. Figures 9 and 10 show S-band system noise temperatures at 6 degrees elevation for all antennas at the eastern and western horizons. These data were measured specifically for rise and set azimuth ranges appropriate for the Galileo spacecraft during the time period 1995 through 1998, but are usable with any spacecraft operating at S-band. All S-band noise temperatures pertaining to DSS-14 include the effect of replacing the LNA-1 maser with a HEMT. The X-band (8420 MHz) system temperatures referenced to the feedhorn aperture for the three antennas are shown in Figures 11 through 13. Each figure shows the noise temperature with the antenna in the lowest noise, X-only configuration, with the S/X dichroic reflector retracted. The higher S/X configuration noise temperatures can be calculated using the parameters given in Appendix A.

The T_{AMW} noise temperature values in Table 2 are stated with reference to the feedhorn aperture and arise from antenna and microwave hardware contribution only. No atmosphere or cosmic background contribution is included. Table 4 presents values (for all antenna frequencies and configurations, at zenith, with average-clear CD = 0.25 weather) of T_{AMW} , T_{sky} , and T_{op} . The values of T_{sky} in Table 4 are calculated by methods presented in Module 105, Rev. B, using year-average attenuation values in Tables 10–15 of that module

Tables 5 through 10 give S-band system noise temperatures to be expected during average clear weather conditions at elevation angles near the horizon, corresponding to rise and set azimuths of spacecraft with declinations of approximately -15° to -25° . These data were gathered specifically to support the Galileo Mission during the 1995 through 1998 period.

Tables 5 and 6 are for rise and set azimuths at DSS-14 (Goldstone) using the S-band SPD cone (the standard S-band receiving system). Tables 7 and 8 are for rise and set azimuths at DSS-43 (Canberra) using the SPD cone, and Tables 9 and 10 give rise and set noise temperatures for DSS-63 (Madrid) using the SPD cone. S-band noise temperatures above the maximum angles given in the tables can be calculated using the parameters given in Appendix A.

3.3 *Pointing*

Figure 15 shows the effects of pointing error on effective transmit and receive gain of the antenna (pointing loss) for the S-band transmit and the L- and S-band receive frequencies. The effects of pointing error at the X-band transmit and receive frequencies are shown in Figure 16. These curves are Gaussian approximations based on theoretical antenna beamwidths. Data have been normalized to eliminate elevation and wind-loading effects. The equation used to generate the curves is provided in Appendix A.

The Gaussian approximation underestimates the exact beam shape by about 0.3 dB at the -5 dB pointing-loss position, and about 0.5 dB at the -6 dB position. Beyond this, the Gaussian approximation will greatly underestimate the pointing loss, as the actual pattern has a null at a position off boresight approximately equal to the full half-power beamwidth. If this is a concern, the exact antenna beam shape should be obtained and pointing loss estimates from that should be made.

Table 1. S- and X-Band Transmit Characteristics

Parameter	Value	Remarks
ANTENNA		
Gain		At elevation angle of peak gain, referenced to feedhorn aperture for matched polarization; no atmosphere included
S-band (2115 MHz)	62.95 ± 0.2 dBi	All stations, S/X dichroic extended
X-band (7145 MHz)	73.23 ± 0.2 dBi	All stations, S/X dichroic retracted
X-band (7145 MHz)	72.92 ± 0.2 dBi	All stations, S/X dichroic extended
Transmitter Waveguide Loss		
S-band		
	0.2 ± 0.02 dB	400-kW transmitter output to feedhorn aperture (DSS-43 only)
	0.3 ± 0.02 dB	20-kW transmitter output to feedhorn aperture (All stations)
X-band	0.45 ± 0.02 dB	20-kW transmitter output to feedhorn aperture (All stations)
Half-Power Beamwidth		Angular width (2-sided) between half-power points at specified frequency
S-band	0.128 ± 0.013 deg	
X-band	0.038 ± 0.004 deg	Note: When operating in the X-only configuration (S/X dichroic retracted), the transmit beam is moved approximately 8.5 mdeg to the left (XEL direction, looking outward from the antenna) relative to the beam in S/X configuration. Existing pointing models correct for this.
Polarization	RCP or LCP	One polarization at a time, remotely selected
Ellipticity, RCP or LCP		Ellipticity is defined as the ratio of peak-to-trough received voltages with a rotating, linearly polarized source and a circularly (elliptically) polarized receiving antenna. Ellipticity (dB) = 20 log (V ₂ /V ₁).
S-band	2.2 dB (max)	All stations
X-band	≤1.0 dB	All stations

Table 1. S- and X-Band Transmit Characteristics (Continued)

Parameter	Value	Remarks
ANTENNA (Continued)		
Pointing Loss		
Angular	See Module 302	Also, see Figures 14 and 15.
CONSCAN		
S-band		
	0.1 dB	Recommended value
	0.03 dB	At S-band, using X-band CONSCAN reference set for 0.1 dB loss
X-band		
	0.1 dB	Recommended value
EXCITER AND TRANSMITTER		
RF Power Output		Nominal output power, referenced to transmitter port; settability is limited to 0.25 dB by measurement equipment precision
S-band		
20-kW Power Amplifier	frequency dependent 73.0, +0.0, -1.0 dBm 70.0, +0.0, -1.0 dBm	2090 to 2110 MHz, emergency only 2110 to 2118 MHz 2118 to 2120 MHz
400-kW Power Amplifier	86.0, +0.0, -1.0 dBm	2110 to 2118 MHz Note: 400-kW power amplifier cannot be used below 10° elevation. 400 kW only available at DSS-43
X-band		
20-kW Power Amplifier	73.0, +0.0, -1.0 dBm	

Both S-band and X-band transmitters employ variable-beam klystron power amplifiers. The output from this kind of amplifier varies across the bandwidth and may be as much as 1 dB below the nominal rating, as indicated by the tolerance. Performance will also vary from tube to tube. Normal procedure is to run the tubes saturated, but unsaturated operation is also possible. The point at which saturation is achieved depends on drive power and beam voltage. The 20-kW tubes are normally saturated for power levels greater than 60 dBm (1 kW) and the 400-kW tubes are saturated above 83 dBm (200 kW). Minimum power out of the 20-kW tubes is about 53 dBm (200 W) and about 73 dBm (20 kW) for the 400-kW tubes. Efficiency of the tubes drops off rapidly below nominal rated output.

Table 1. S- and X-Band Transmit Characteristics (Continued)

Parameter	Value	Remarks
EXCITER AND TRANSMITTER (Continued)		
EIRP		At elevation angle of peak gain, referenced to feedhorn aperture
S-band	frequency dependent 135.6, +0.0, -1.0 dBm 132.6, +0.0, -1.0 dBm	20-kW transmitter, S/X dichroic extended 2090 to 2110 MHz, emergency only 2110 to 2118 MHz 2118 to 2120 MHz
	148.7, +0.0, -1.0 dBm	400-kW transmitter, S/X dichroic extended 2110 to 2118 MHz (DSS-43 only)
X-band	145.8, +0.0, -1.0 dBm	20-kW transmitter, S/X dichroic retracted
	145.5, +0.0, -1.0 dBm	20-kW transmitter, S/X dichroic extended
Frequency Range Covered		
S-band		
1-dB Bandwidth	2090 to 2091 MHz 2110 to 2118 MHz	Power decreases above 2118 MHz
Coherent with Deep Space S-band D/L Allocation	2110.2 to 2117.7 MHz	240/221 turnaround ratio
Coherent with Deep Space X-band D/L Allocation	2110.2 to 2119.8 MHz	880/221 turnaround ratio
X-band		
1-dB Bandwidth	7145 to 7190 MHz	
Coherent with Deep Space S-band D/L Allocation	7147.3 to 7177.3 MHz	240/749 turnaround ratio
Coherent with Deep Space X-band D/L Allocation	7149.6 to 7188.9 MHz	880/749 turnaround ratio
Tunability		At S-band or X-band transmitter output frequency
Phase Continuous Tuning Range	2.0 MHz	About any frequency within covered frequency ranges
Maximum Tuning Rate	± 12.1 kHz/s	

Table 1. S- and X-Band Transmit Characteristics (Continued)

Parameter	Value	Remarks
EXCITER AND TRANSMITTER (Continued)		
Frequency Error	0.012 Hz	Average over 100 ms with respect to frequency specified by predicts
Ramp Rate Error	0.001 Hz/s	Average over 4.5 s with respect to rate calculated from frequency predicts
S-Band Stability		At transmitter output frequency
Output Power Stability		12-h period
Saturated Drive	± 0.25 dB	20-kW transmitter
Saturated Drive	± 0.5 dB	400-kW transmitter
Unsaturated Drive	± 1.0 dB	20-kW and 400-kW transmitters
Frequency ($\Delta f/f$), 1000-s Averaging	5×10^{-15}	Allan deviation
Phase Stability		In 1-Hz bandwidth
1–10 Hz Offset	–60 dBc	Below carrier
10 Hz–1 kHz Offset	–70 dBc	Below carrier
Group Delay Stability	≤3.3 ns	Ranging modulation signal path over 12-h period (see Module 203)
Spurious Output		
2nd Harmonic	–85 dBc	Below Carrier
3rd Harmonic	–85 dBc	Below Carrier
4th Harmonic	–140 dBm	20-kW transmitter
4th Harmonic	TBD	400-kW transmitter
X-Band Stability		At transmitter output frequency
Output Power Stability		12-h period
Saturated Drive	± 0.25 dB	
Unsaturated Drive	± 1.0 dB	
Frequency ($\Delta f/f$), 1000-s Averaging	2.3×10^{-15}	Allan deviation

Table 1. S- and X-Band Transmit Characteristics (Continued)

Parameter	Value	Remarks
EXCITER AND TRANSMITTER (Continued)		
X-Band Stability (Continued)		At transmitter output frequency
Phase Stability		In 1-Hz bandwidth
1–10 Hz Offset	–50 dBc	Below carrier
10 Hz–1 kHz Offset	–60 dBc	Below carrier
Group Delay Stability	≤1.0 ns	Ranging modulation signal path over 12 h period (see Module 203)
Spurious Output		
2nd Harmonic	–75 dBc	Below carrier
3rd, 4th & 5th Harmonics	–60 dBc	Below carrier

Table 2. L-, S-, and X-Band Receive Characteristics

Parameter	Value	Remarks
ANTENNA		
Gain		At elevation angle of peak gain for matched polarization, no atmosphere included. Favorable (+) and adverse (–) tolerances have a triangular PDF. See Figures 3–6 for elevation dependency.
L-Band (1668 MHz)	61.04 ± 0.3 dBi	Referenced to feedhorn aperture
S-Band (2295 MHz), All Stations	63.59 ± 0.1 dBi	Referenced to feedhorn aperture. S/X dichroic extended.
X-Band (8420 MHz), X-only Configuration		Referenced to feedhorn aperture. S/X dichroic retracted.
DSS-14	74.55 ± 0.1 dBi	
DSS-43	74.63 ± 0.1 dBi	
DSS-63	74.66 ± 0.1 dBi	
X-Band (8420 MHz), S/X Configuration		Referenced to feedhorn aperture. S/X dichroic extended.
DSS-14	74.35 ± 0.1 dBi	
DSS-43	74.36 ± 0.1 dBi	
DSS-63	74.19 ± 0.1 dBi	
Half-Power Beamwidth		Angular width (2-sided) between half-power points at specified frequency
L-Band (1668 MHz)	0.162 ± 0.016 deg	
S-Band (2295 MHz)	0.118 ± 0.012 deg	
X-Band (8420 MHz)	0.032 ± 0.003 deg	Note: When operating in the X-only configuration (S/X dichroic retracted) the receive beam is moved approximately 8.5 mdeg to the left (XEL direction, looking outward from the antenna) relative to the beam in S/X configuration. Existing pointing models correct for this.

Table 2. L-, S-, and X-Band Receive Characteristics (Continued)

Parameter	Value	Remarks
ANTENNA (Continued)		
Polarization		
L-Band, All Stations	LCP	RCP available by changing mechanical configuration of feed
S-Band, All Stations	RCP and LCP	Both polarizations are available simultaneously. Choice of diplexed or non-diplexed path is remotely selectable.
X-Band, All Stations	RCP and LCP	Both polarizations are available simultaneously.
Ellipticity		
L-Band	2.0 dB (max)	
S-Band	0.6 dB (max)	
X-Band	0.8 dB (max)	
Pointing Loss		
Angular	See Module 302	Also, see Figures 14 and 15.
CONSCAN		
S-Band	0.03 dB, 3 sigma	At S-band using X-band CONSCAN reference set for 0.1 dB loss at X-band
	0.1 dB, 3 sigma	Recommended value when using S-band CONSCAN reference
X-Band	0.1 dB, 3 sigma	Recommended value when using X-band CONSCAN reference
LOW NOISE AMPLIFIERS AND RECEIVERS		
		Two tracking receivers are normally provided, which may be operated as one S- and one X-band receiver. RCP and LCP are simultaneously available at S- and X-bands so one receiver can be used on each polarization. When tracking at L-band, S- and X-band are not available. Additional receivers (up to 4, total, per polarization) can be scheduled subject to availability.

Table 2. L-, S-, and X-Band Receive Characteristics (Continued)

Parameter	Value	Remarks
LOW NOISE AMPLIFIERS AND RECEIVERS (Continued)		
Frequency Ranges Covered		1 dB bandwidth
L-Band	1628 to 1708 MHz	
S-Band	2270 to 2300 MHz 2200 to 2300 MHz	maser HEMT
X-Band	8200 to 8600 MHz	Deep Space downlink telemetry allocation is 8400 to 8450 MHz
Recommended Maximum Signal Power	-90.0 dBm -80.0 dBm	At LNA input terminal maser HEMT
Antenna-Microwave Noise Temperature (T_{AMW})		Near zenith, no atmosphere (vacuum) or cosmic noise included. See Table 4 for 25% CD average clear sky noise contribution. Favorable (-) and adverse (+) tolerances have triangular PDF.
L-Band, all stations (1628–1708 MHz) LNA-1 or -2, HEMT	26.68 ± 2 K	With respect to feedhorn aperture. See Figure 7 for elevation dependency.
S-Band (2270–2300 MHz)		With respect to feedhorn aperture. See Figure 8 for DSS-14 elevation dependency.
DSS-14, LNA-1, HEMT, non-diplexed	12.24 ± 1 K	
DSS-14, LNA-1, HEMT, diplexed	16.79 ± 1 K	
DSS-14, LNA-2, HEMT, non-diplexed	18.80 ± 1 K	
DSS-14, LNA-2, HEMT, diplexed	23.74 ± 1 K	
DSS-43, LNA-1, maser, non-diplexed	11.29 ± 1 K	
DSS-43, LNA-1, maser, diplexed	16.00 ± 1 K	

Table 2. L-, S-, and X-Band Receive Characteristics (Continued)

Parameter	Value	Remarks
LOW NOISE AMPLIFIERS AND RECEIVERS (Continued)		
Antenna-Microwave Noise Temperature (T_{AMW})		
S-Band (2270–2300 MHz), (Continued)		
DSS-43, LNA-2, HEMT, non-diplexed	19.59 ± 1 K	
DSS-43, LNA-2, HEMT, diplexed	24.72 ± 1 K	
DSS-63, LNA-1, maser, non-diplexed	10.70 ± 1 K	
DSS-63, LNA-1, maser, diplexed	15.81 ± 1 K	
DSS-63, LNA-2, HEMT, non-diplexed	21.24 ± 1 K	
DSS-63, LNA-2, HEMT, diplexed	26.85 ± 1 K	
X-Band (8400–8500 MHz), X-Only Configuration		Referenced to feedhorn aperture. No atmosphere (vacuum) or cosmic noise included. S/X dichroic plate retracted. See Figures 11–13 for elevation dependency.
DSS-14, LNA-1/-2, HEMT	11.65 ± 1 K	
DSS-43, LNA-1/-2, HEMT	12.10 ± 1 K	
DSS-63, LNA-1/-2, HEMT	11.46 ± 1 K	
X-Band (8400–8500 MHz) S/X Configuration		Referenced to feedhorn aperture. No atmosphere (vacuum) or cosmic noise included. S/X dichroic plate extended.
DSS-14, LNA-1/-2, HEMT	12.59 ± 1 K	
DSS-43, LNA-1/-2, HEMT	13.32 ± 1 K	
DSS-63, LNA-1/-2, HEMT	12.64 ± 1 K	
Carrier Tracking Loop Noise B/W	0.25 – 200 Hz	Effective one-sided, noise-equivalent carrier loop bandwidth (B_L). See module 202.

Table 3. Gain Reduction Due to Wind Loading, 70-m Antenna

Wind Speed		Gain Reduction (dB)*	
km/h	mph	S-Band	X-Band
32	20	Negligible	0.1
48	30	Negligible	0.3
72	45	0.15	1.5

* Assumes antenna is maintained on-point using CONSCAN or an equivalent. L-band gain reduction is negligible for wind speeds up to 72 km/h (45 mph). Worst case with antenna in most adverse orientation for wind.

Table 4. T_{AMW} , T_{sky} , and T_{op} for CD=25% Average Clear Weather at Zenith, Referenced to Feedhorn Aperture

Configuration and Stations	Noise Temperatures, K		
	T_{AMW}	T_{sky}	T_{op}
L-band , all stations, LNA-1 or -2, HEMT, LCP, non-diplexed	26.68	4.78	31.46
S-band , DSS 14, SPD cone, LNA-1, HEMT, non-diplexed	12.24	4.68	16.92
S-band , DSS 14, SPD cone, LNA-1, HEMT, diplexed	16.79	4.68	21.47
S-band , DSS 14, Mod III, LNA-2, HEMT, non-diplexed	18.80	4.68	23.48
S-band , DSS 14, Mod III, LNA-2, HEMT, diplexed	23.74	4.68	28.42
S-band , DSS 43, SPD cone, LNA-1, maser, non-diplexed	11.29	4.86	16.15
S-band , DSS 43, SPD cone, LNA-1, maser, diplexed	16.00	4.86	20.86
S-band , DSS 43, Mod III, LNA-2, HEMT, non-diplexed	19.59	4.86	24.45
S-band , DSS 43, Mod III, LNA-2, HEMT, diplexed	24.72	4.86	29.58
S-band , DSS 63, SPD cone, LNA-1, maser, non-diplexed	10.70	4.80	15.50
S-band , DSS 63, SPD cone, LNA-1, maser, diplexed	15.81	4.80	20.61
S-band , DSS 63, Mod III, LNA-2, HEMT, non-diplexed	21.24	4.80	26.04
S-band , DSS 63, Mod III, LNA-2, HEMT, diplexed	26.85	4.80	31.65

Table 4. T_{AMW} , T_{sky} , and T_{op} for CD=25% Average Clear Weather at Zenith, Referenced to Feedhorn Aperture (Continued)

Configuration and Stations	Noise Temperatures, K		
	T_{AMW}	T_{sky}	T_{op}
X-band , DSS 14, XTR cone, LNA-1, HEMT, RCP, X-only mode	11.65	5.04	16.69
X-band , DSS 14, XTR cone, LNA-2, HEMT, LCP, X-only mode	11.65	5.04	16.69
X-band , DSS 14, XTR cone, LNA-1, HEMT, RCP, S/X mode	12.59	5.04	17.63
X-band , DSS 14, XTR cone, LNA-2, HEMT, LCP, S/X mode	12.59	5.04	17.63
X-band , DSS 43, XTR cone, LNA-1, HEMT, RCP, X-only mode	12.10	5.39	17.49
X-band , DSS 43, XTR cone, LNA-2, HEMT, LCP, X-only mode	12.10	5.39	17.49
X-band , DSS 43, XTR cone, LNA-1, HEMT, RCP, S/X mode	13.32	5.39	18.71
X-band , DSS 43, XTR cone, LNA-2, HEMT, LCP, S/X mode	13.32	5.39	18.71
X-band , DSS 63, XTR cone, LNA-1, HEMT, RCP, X-only mode	11.46	5.27	16.73
X-band , DSS 63, XTR cone, LNA-2, HEMT, LCP, X-only mode	11.46	5.27	16.73
X-band , DSS 63, XTR cone, LNA-1, HEMT, RCP, S/X mode	12.64	5.27	17.91
X-band , DSS 63, XTR cone, LNA-2, HEMT, LCP, S/X mode	12.64	5.27	17.91

810-005
101, Rev. D

Table 5. DSS 14 Eastern Horizon S-Band T_{op} (K) with SPD Cone

ELEV, deg	AZIMUTH, deg																				
	110	111	112	113	114	115	116	117	118	119	120	121	122	123	124	125	126	127	128	129	130
20.0	22.8	22.9	22.8	22.8	22.8	22.9	22.8	22.8	22.8	22.9	22.9	23.0	22.9	22.9	22.9	22.9	22.9	22.9	22.9	22.9	22.9
19.0	23.3	23.3	23.3	23.3	23.3	23.3	23.4	23.5	23.5	23.5	23.4	23.4	23.5	23.5	23.5	23.6	23.6	23.5	23.4	23.4	23.4
18.0	23.9	23.8	23.8	23.8	23.8	23.7	23.7	23.8	23.8	23.8	23.9	23.8	23.8	23.8	23.9	23.9	23.8	23.8	23.8	23.7	23.8
17.0	24.1	24.0	24.0	24.0	23.9	24.0	24.0	24.1	24.0	24.0	24.0	24.0	24.0	24.0	24.0	24.0	24.1	24.0	24.0	24.1	24.1
16.0	24.5	24.5	24.5	24.4	24.5	24.4	24.4	24.4	24.5	24.5	24.4	24.5	24.5	24.5	24.4	24.5	24.5	24.5	24.5	24.7	24.8
15.0	25.0	25.0	25.0	25.0	25.0	25.0	25.1	25.1	25.0	25.1	25.2	25.3	25.3	25.3	25.3	25.4	25.4	25.4	25.4	25.5	25.5
14.0	25.5	25.5	25.5	25.6	25.6	25.6	25.7	25.7	25.7	25.8	25.9	25.9	25.8	25.8	25.8	25.9	26.1	26.1	26.0	26.0	26.0
13.0	26.4	26.3	26.3	26.4	26.4	26.3	26.3	26.4	26.4	26.4	26.4	26.5	26.5	26.5	26.6	26.6	26.5	26.6	26.6	26.7	26.7
12.0	27.0	27.0	27.0	27.0	27.0	27.0	27.1	27.1	27.1	27.2	27.2	27.1	27.2	27.2	27.1	27.1	27.2	27.2	27.2	27.3	27.3
11.0	27.8	27.9	27.9	27.9	27.8	27.9	27.9	27.9	27.9	27.9	28.0	28.0	28.0	28.0	28.0	28.0	28.1	28.1	28.1	28.2	28.3
10.0	28.9	29.0	29.0	28.9	29.0	28.9	29.0	29.0	28.9	29.0	29.0	29.1	29.1	29.1	29.2	29.1	29.1	29.2	29.2	29.3	29.2
9.5	29.2	29.3	29.3	29.4	29.3	29.4	29.4	29.4	29.4	29.4	29.4	29.5	29.6	29.4	29.5	29.5	29.6	29.7	29.8	29.7	29.8
9.0	29.7	29.6	30.0	30.0	29.6	29.6	29.6	29.6	29.6	29.7	29.7	29.8	29.8	29.8	29.9	29.9	29.9	30.3	30.3	30.0	30.0
8.5	31.0	31.0	30.9	30.9	31.0	30.9	30.8	30.8	30.9	30.9	30.9	30.9	31.0	31.1	31.3	31.3	31.2	31.1	31.2	31.3	31.3
8.0	31.4	31.4	31.5	31.5	31.7	31.7	31.6	31.5	31.6	31.6	31.6	31.8	31.8	31.7	31.7	31.7	31.7	31.8	31.8	31.9	31.9
7.5	32.2	32.1	32.1	32.2	32.2	32.2	32.3	32.2	32.2	32.3	32.2	32.3	32.6	32.4	32.4	32.5	32.5	32.5	32.6	32.6	32.7
7.0	32.9	33.0	33.0	33.0	33.0	33.2	33.2	33.0	33.1	33.1	33.1	33.1	33.1	33.2	33.2	33.2	33.3	33.3	33.3	33.4	33.5
6.5	33.9	34.0	34.3	34.1	34.1	34.4	34.2	34.2	34.2	34.3	34.3	34.4	34.3	34.3	34.3	34.4	34.5	34.4	34.5	34.6	34.6
6.0	34.1	34.6	34.8	34.8	34.8	34.8	34.9	35.0	35.0	35.0	35.1	35.1	35.1	35.1	35.1	35.2	35.3	35.4	35.4	35.4	35.6
	AZIMUTH, deg																				
	130	131	132	133	134	135	136	137	138	139	140	141	142	143	144	145	146	147	148	149	150
20.0	22.9	22.9	22.9	22.9	22.9	23.0	23.0	23.5	23.4	22.9	23.0	23.0	23.0	23.0	22.9	22.9	23.0	23.0	23.0	23.0	23.0
19.0	23.4	23.4	23.4	23.4	23.4	23.4	23.3	23.5	23.9	23.6	23.4	23.6	23.8	23.4	23.4	23.9	23.7	23.4	23.4	23.4	23.4
18.0	23.8	23.8	23.7	23.7	23.7	23.8	23.8	23.7	23.8	23.9	23.9	23.9	24.3	24.4	23.9	24.0	24.6	24.3	23.9	24.1	24.6
17.0	24.1	24.2	24.3	24.4	24.3	24.3	24.3	24.2	24.3	24.3	24.4	24.4	24.4	24.4	24.3	24.3	24.3	24.4	24.3	24.4	24.5
16.0	24.8	24.6	24.6	24.7	24.7	24.7	24.8	24.8	24.9	24.9	24.9	25.0	25.1	25.0	24.9	25.1	25.1	24.9	24.9	25.0	25.0
15.0	25.5	25.4	25.4	25.5	25.4	25.4	25.4	25.5	25.5	25.5	25.6	25.6	25.6	25.6	25.6	25.5	25.5	25.6	25.6	25.5	25.5
14.0	26.0	26.0	26.0	26.0	26.3	26.7	26.4	26.3	26.3	26.3	26.3	26.2	26.2	26.3	26.3	26.3	26.3	26.5	26.8	26.4	26.4
13.0	26.7	26.7	26.8	26.8	26.9	27.0	26.8	26.6	26.8	26.9	27.0	27.0	27.1	27.1	27.1	27.1	27.1	27.3	27.3	27.3	27.3
12.0	27.3	27.3	27.3	27.4	27.4	27.4	27.4	27.4	27.5	27.5	27.5	27.6	27.6	27.7	27.7	27.7	27.7	27.8	27.8	27.8	27.9
11.0	28.3	28.3	28.3	28.7	29.3	28.6	28.6	29.1	28.6	28.4	28.4	28.5	28.4	28.5	28.5	28.5	28.5	28.6	28.7	28.7	28.7
10.0	29.2	29.3	29.3	29.5	29.5	29.4	29.5	29.5	29.5	29.6	29.6	29.7	29.6	29.6	29.5	29.7	29.7	29.7	29.7	29.8	29.9
9.5	29.8	29.8	29.9	29.9	30.0	29.9	29.9	29.9	29.9	30.0	30.0	30.1	30.1	30.1	30.2	30.2	30.2	30.3	30.2	30.2	30.2
9.0	30.0	30.1	30.1	30.2	30.2	30.2	30.3	30.3	30.4	30.4	30.3	30.4	30.5	30.6	30.5	30.6	30.6	30.7	30.7	30.7	30.7
8.5	31.3	31.4	31.5	31.4	31.5	31.7	31.7	31.7	31.8	31.4	31.7	31.9	31.6	31.6	31.8	31.8	31.7	31.7	31.8	31.8	31.8
8.0	31.9	31.9	32.0	32.0	32.1	32.3	32.2	32.1	32.2	32.3	32.2	32.3	32.2	32.1	32.3	32.4	32.4	32.4	32.4	32.5	32.6
7.5	32.7	32.7	32.7	32.9	33.0	33.0	33.0	33.0	33.1	33.2	33.3	33.2	33.2	33.2	33.3	33.3	33.3	33.3	33.4	33.5	33.6
7.0	33.5	33.6	33.7	33.6	33.8	33.9	33.9	34.0	33.9	33.8	33.9	34.0	34.0	34.0	34.0	34.0	34.1	34.2	34.3	34.6	34.7
6.5	34.6	34.7	34.7	34.8	34.9	35.0	35.0	35.0	35.0	35.1	35.4	35.3	35.2	35.2	35.2	35.3	35.4	35.5	35.7	35.9	36.0
6.0	35.6	35.6	35.6	35.8	35.8	35.8	35.9	35.9	35.9	36.1	36.1	36.2	36.2	36.3	36.4	36.4	36.5	36.6	36.8	37.0	37.2

Table 6. DSS 14 Western Horizon S-Band T_{op} (K) with SPD Cone

ELEV, deg	AZIMUTH, deg																				
	210	211	212	213	214	215	216	217	218	219	220	221	222	223	224	225	226	227	228	229	230
9.0	31.5	31.8	32.8	33.8	33.3	32.4	31.8	31.4	31.1	31.1	31.0	30.9	30.8	30.8	30.6	30.8	30.8	30.9	30.8	30.8	30.8
8.5	32.8	33.1	34.1	34.1	33.0	32.4	32.1	31.8	31.7	31.5	31.5	31.5	31.4	31.4	31.3	31.3	31.3	31.3	31.3	31.3	31.3
8.0	29.0	33.3	33.7	34.9	35.6	34.2	33.1	32.9	32.8	32.5	32.4	32.3	32.3	32.6	32.2	32.1	32.2	32.5	32.3	32.2	32.3
7.5	36.5	36.7	36.7	36.7	36.3	35.1	34.1	33.8	33.5	33.2	33.1	33.0	33.0	33.0	33.0	33.0	32.9	32.8	32.7	32.8	32.9
7.0	36.1	36.1	36.1	36.0	36.0	36.0	35.6	34.8	34.3	34.0	33.9	33.5	33.7	33.7	33.7	33.6	33.6	33.6	33.5	33.5	33.6
6.5	36.2	36.1	36.0	36.1	36.0	35.6	35.2	34.8	34.7	34.8	34.6	34.6	34.6	34.6	34.8	34.6	34.6	34.5	34.5	34.5	34.5
6.0	36.4	35.9	36.5	36.6	36.6	36.5	36.2	35.8	35.6	35.5	35.5	35.5	35.5	35.5	35.4	35.4	35.4	35.3	35.4	35.3	35.4
	AZIMUTH, deg																				
	230	231	232	233	234	235	236	237	238	239	240	241	242	243	244	245	246	247	248	249	250
9.0	30.8	30.7	30.7	30.7	30.9	30.9	30.7	30.9	31.2	30.7	30.6	30.6	30.6	30.5	30.6	30.6	30.5	30.5	30.6	30.7	30.8
8.5	31.3	31.2	31.2	31.2	31.3	31.5	31.3	31.3	31.2	31.1	31.2	31.2	31.2	31.2	31.2	31.2	31.2	31.3	31.3	31.3	31.3
8.0	32.3	32.1	32.0	32.0	31.9	32.0	32.0	31.7	31.8	31.9	32.0	32.0	32.0	31.9	31.9	31.9	31.8	31.9	32.0	32.0	32.1
7.5	32.9	32.8	32.8	32.8	32.7	32.7	32.7	32.8	32.8	32.7	32.4	32.7	32.9	32.8	32.8	32.9	32.7	32.7	32.7	32.5	32.3
7.0	33.6	33.6	33.5	33.5	33.6	33.6	33.5	33.5	33.5	33.5	33.5	33.5	33.4	33.4	33.4	33.2	33.4	33.5	33.5	33.4	33.5
6.5	34.5	34.4	34.4	34.4	34.4	34.4	34.4	34.4	34.4	34.4	34.4	34.3	34.3	34.4	34.4	34.3	34.3	34.3	34.4	34.3	34.3
6.0	35.4	35.5	35.4	35.5	35.7	35.7	35.6	35.6	35.7	35.6	35.6	35.6	35.6	35.5	35.5	35.5	35.5	35.5	35.6	35.6	35.6

810-005
101, Rev. D

Table 7. DSS 43 Eastern Horizon S-Band T_{op} (K) with SPD Cone

ELEV, deg	AZIMUTH, deg																				
	90	91	92	93	94	95	96	97	98	99	100	101	102	103	104	105	106	107	108	109	110
20.0	23.3	23.0	22.5	23.2	22.7	23.0	23.3	23.1	22.7	23.0	23.1	22.8	22.5	23.2	22.9	23.0	22.6	23.3	22.6	22.4	23.0
19.0	23.7	23.8	23.6	23.5	23.8	24.4	23.9	23.7	23.6	23.6	23.2	23.0	23.5	23.7	23.1	23.7	23.3	23.3	23.2	23.4	23.1
18.0	24.6	24.3	24.5	23.9	24.0	24.2	24.4	24.5	24.4	24.2	24.5	23.9	24.5	24.4	24.2	24.1	23.9	23.8	24.3	23.9	23.7
17.0	25.4	25.5	24.7	24.9	25.2	24.7	25.5	25.1	25.5	25.4	25.0	25.2	25.1	24.7	24.7	25.2	25.2	24.6	24.5	24.6	25.0
16.0	25.8	25.8	25.4	26.0	25.6	25.8	25.7	25.9	25.7	25.4	25.9	25.6	25.9	25.6	25.7	25.8	25.8	25.5	25.5	25.0	25.3
15.0	27.1	27.0	26.3	26.7	26.5	26.6	26.3	27.0	26.4	27.0	26.6	26.5	26.7	26.6	25.9	26.4	26.6	26.6	26.3	26.1	26.1
14.0	27.6	27.9	27.5	27.8	27.8	27.3	27.6	27.4	27.4	27.5	27.5	27.8	27.6	27.6	27.1	27.2	27.3	27.4	26.7	27.1	26.7
13.0	28.6	28.0	28.3	28.6	28.1	28.9	28.4	28.0	28.3	28.6	28.0	28.2	28.2	28.4	28.1	28.1	28.0	28.1	28.3	27.8	27.9
12.0	29.4	29.6	29.5	30.0	29.5	29.8	29.7	29.7	29.5	29.9	29.4	29.6	29.3	29.3	29.2	29.3	29.4	29.2	28.7	29.1	28.9
11.0	30.8	31.2	30.7	30.3	30.4	31.0	30.6	31.2	31.8	31.1	31.4	31.8	31.2	31.1	31.3	30.3	30.3	30.4	30.3	30.2	30.1
10.0	37.9	37.1	34.9	34.0	33.7	33.7	34.4	37.6	44.2	55.7	62.6	63.4	60.4	52.9	41.4	35.0	33.0	32.1	32.3	31.6	31.5
9.5	54.8	54.4	51.2	46.0	42.8	43.5	49.3	58.2	71.8	86.5	98.6	102	98.3	86.7	71.6	57.6	44.6	36.0	34.2	33.3	32.0
9.0	81.3	80.4	75.9	70.9	69.3	74.0	84.8	100	118	135	145	146	137	120	101	82.2	64.7	50.1	42.9	38.4	35.6
8.5	115	116	115	111	108	108	116	129	147	165	181	191	188	177	159	138	115	95.2	79.4	68.7	58.9
8.0	155	154	152	149	150	155	165	181	199	215	226	227	219	205	186	164	145	128	113	101	86.5
7.5	194	195	195	192	189	191	199	211	226	238	244	244	242	240	231	215	199	182	169	157	138
7.0	223	224	224	222	220	224	231	240	244	246	246	245	244	244	242	236	226	216	207	194	175
6.5	239	240	241	241	240	240	243	244	247	248	248	247	246	245	245	246	245	242	240	234	224
6.0	243	244	243	243	244	244	245	246	247	247	247	246	245	246	246	246	246	245	245	243	237
	AZIMUTH, deg																				
	110	111	112	113	114	115	116	117	118	119	120	121	122	123	124	125	126	127	128	129	130
20.0	23.0	22.6	22.6	22.0	22.4	21.7	22.2	22.0	22.4	21.9	22.3	21.9	21.7	21.8	21.8	22.3	22.2	22.2	21.5	21.8	22.0
19.0	23.1	23.0	23.2	23.2	23.3	22.6	23.1	22.7	22.8	23.0	22.7	22.1	22.6	22.2	22.9	22.3	22.4	22.2	22.3	22.5	22.1
18.0	23.7	24.1	23.8	24.0	23.5	23.8	23.3	23.1	23.5	23.1	23.2	23.2	23.1	23.2	23.2	23.0	22.8	23.2	22.8	23.0	23.2
17.0	25.0	24.4	24.6	24.2	24.6	23.9	24.8	23.9	23.9	23.9	24.1	24.1	23.8	23.8	23.9	23.8	23.7	23.6	23.8	23.3	23.0
16.0	25.3	25.1	25.6	25.2	25.1	25.2	25.0	24.4	24.7	25.1	24.6	24.1	24.7	24.1	24.5	24.1	24.2	24.4	24.0	24.3	25.2
15.0	26.1	25.9	25.9	25.8	25.8	25.8	25.6	25.8	25.6	25.3	25.6	25.6	25.2	25.2	25.6	25.2	25.2	24.9	25.1	25.0	24.6
14.0	26.7	26.7	26.7	27.0	26.7	26.7	26.5	26.5	26.6	26.4	26.4	25.9	26.2	26.0	26.1	26.0	26.2	26.0	25.4	25.6	25.4
13.0	27.9	28.3	27.5	27.6	27.6	27.5	27.4	27.2	27.3	27.3	27.3	28.0	27.0	26.8	27.5	26.7	26.6	26.5	26.9	27.1	26.4
12.0	28.9	28.6	28.1	28.6	28.6	28.5	28.4	28.2	28.5	27.7	28.1	27.6	28.0	28.3	28.1	28.1	27.8	27.9	27.8	27.6	27.6
11.0	30.1	30.1	29.8	29.8	29.6	29.2	29.4	29.5	29.6	28.9	29.3	29.2	28.9	29.6	29.2	29.5	28.9	29.1	28.6	29.1	29.4
10.0	31.5	31.6	31.4	30.6	30.8	30.7	30.5	31.1	30.4	30.4	30.3	30.6	30.5	30.7	30.6	31.6	32.3	31.6	30.7	30.5	30.5
9.5	32.0	32.8	32.7	31.4	32.1	31.5	31.3	31.3	31.0	30.9	31.3	30.7	31.0	31.5	30.9	31.2	30.8	31.2	31.1	30.8	30.8
9.0	35.6	34.0	33.1	33.1	32.9	32.5	32.5	32.2	32.3	32.2	32.0	31.5	31.8	31.8	31.7	31.8	31.5	31.8	31.8	31.8	31.0
8.5	58.9	45.9	37.9	34.3	34.0	33.3	33.1	33.4	33.5	33.0	32.8	32.8	32.7	33.0	32.9	32.7	33.2	32.8	33.2	32.7	32.5
8.0	86.5	67.9	50.6	40.4	35.9	34.8	34.1	33.8	34.3	34.0	33.8	33.6	33.8	33.9	33.9	33.7	34.7	34.3	34.7	33.9	34.2
7.5	138	117	93.3	72.3	55.1	42.3	37.4	35.7	35.4	35.8	35.7	35.1	35.6	35.8	35.8	35.7	35.7	35.6	36.1	35.7	35.8
7.0	175	151	126	101	78.4	57.0	41.4	38.3	37.5	38.1	37.8	37.6	38.4	38.1	38.2	38.6	38.3	37.7	38.1	37.9	37.0
6.5	224	204	182	157	130	104	76.3	52.7	42.5	40.5	41.2	41.7	41.9	43.9	45.5	46.8	45.7	42.8	41.5	40.3	41.0
6.0	237	223	203	179	152	120	90.0	65.4	51.2	47.0	47.1	50.6	56.8	64.5	68.9	67.7	61.0	52.9	47.3	44.3	43.7

Table 8. DSS 43 Western Horizon S-Band T_{op} (K) with SPD Cone

ELEV, deg	AZIMUTH, deg																				
	230	231	232	233	234	235	236	237	238	239	240	241	242	243	244	245	246	247	248	249	250
20.0	21.7	21.6	21.7	21.8	21.6	21.9	21.7	21.8	22.0	21.8	21.8	21.8	21.7	21.9	22.0	21.7	21.9	21.9	21.8	21.9	21.8
19.0	22.3	22.3	22.5	22.4	22.5	22.5	22.4	22.5	22.4	22.6	22.6	22.5	22.6	22.8	22.6	22.5	22.4	22.5	22.6	22.6	22.5
18.0	23.0	22.9	23.0	23.0	23.1	23.3	23.1	23.0	23.2	23.3	23.3	23.2	23.2	23.3	23.1	23.2	23.2	23.1	23.2	23.2	23.0
17.0	23.7	23.6	23.8	23.7	23.7	23.7	23.7	23.9	23.8	23.7	23.9	23.8	23.9	23.7	23.8	23.7	23.7	23.8	23.6	23.8	23.8
16.0	24.3	24.4	24.3	24.5	24.7	24.5	24.5	24.6	24.6	24.5	24.6	24.6	24.5	24.4	24.5	24.5	24.7	24.4	24.5	24.4	24.6
15.0	25.2	25.2	25.3	25.2	25.3	25.3	25.3	25.3	25.4	25.4	25.3	25.4	25.4	25.4	25.3	25.3	25.3	25.2	25.4	25.5	25.2
14.0	26.2	26.0	25.9	25.9	25.9	26.0	26.2	26.1	26.2	26.1	26.2	26.2	26.3	26.2	26.2	26.2	26.2	26.1	26.1	26.0	26.0
13.0	26.8	26.8	27.0	26.9	26.9	26.9	26.9	27.0	26.9	27.0	27.0	27.1	27.1	26.9	27.1	27.0	27.0	27.0	27.1	27.0	26.8
12.0	27.8	27.7	27.7	27.8	27.8	27.9	28.0	27.9	28.0	27.9	28.2	28.0	28.1	28.2	28.1	28.2	28.1	28.0	28.0	28.0	28.0
11.0	29.2	29.3	29.4	29.5	29.4	29.5	29.6	29.7	29.6	29.7	29.5	29.6	29.7	29.7	29.8	29.8	29.7	29.6	29.6	29.5	29.3
10.5	29.4	29.5	29.4	29.7	29.7	30.0	29.9	30.4	31.1	31.1	30.7	30.3	30.8	31.4	30.8	31.0	31.8	31.6	30.3	29.9	30.0
10.0	30.2	30.3	30.9	31.7	31.7	31.7	33.1	35.7	36.3	35.7	34.0	33.8	36.4	35.5	34.1	37.1	37.0	33.3	31.7	31.4	31.4
9.5	32.0	32.3	32.3	34.6	37.1	36.9	37.3	39.6	42.9	43.6	43.9	41.3	41.1	42.8	42.2	41.7	43.6	42.1	38.5	35.7	34.7
9.0	38.3	38.7	40.7	43.7	45.5	48.0	48.8	52.3	52.8	54.6	55.6	54.3	52.8	53.4	54.5	53.8	52.1	49.3	46.9	42.9	44.0
8.5	44.7	47.1	50.8	53.8	54.8	59.3	63.0	65.6	66.3	66.2	71.0	70.4	68.7	67.1	70.0	69.5	66.3	62.7	61.9	59.8	55.4
8.0	58.9	64.0	68.7	67.5	73.5	78.9	82.0	82.5	82.6	88.2	89.3	87.8	85.1	87.5	88.4	84.4	79.1	77.7	78.0	72.7	68.4
7.5	72.9	74.3	82.4	86.0	84.8	93.1	98.9	102	101	103	108	110	107	105	108	108	101	96.3	96.9	96.4	89.8
7.0	91.0	97.0	105	103	107	116	122	120	122	125	132	129	127	128	131	124	116	117	117	114	107
6.5	110	115	124	124	125	134	142	141	142	145	149	153	149	148	151	150	142	137	139	137	131
6.0	133	140	147	145	148	158	163	163	165	168	174	172	170	172	173	170	163	159	160	156	149

ELEV, deg	AZIMUTH, deg																				
	250	251	252	253	254	255	256	257	258	259	260	261	262	263	264	265	266	267	268	269	270
20.0	21.8	21.9	21.6	21.9	21.6	21.7	21.7	21.8	21.7	21.7	21.7	21.7	21.7	21.7	21.6	21.8	21.8	21.7	21.6	21.7	21.9
19.0	22.5	22.5	22.5	22.4	22.4	22.5	22.3	22.4	22.3	22.3	22.3	22.4	22.4	22.3	22.3	22.2	22.2	22.2	22.2	22.1	22.3
18.0	23.0	23.2	23.1	23.1	23.2	23.1	23.1	23.0	22.9	22.9	22.9	22.9	22.9	22.9	22.8	22.9	22.8	22.9	22.8	22.8	22.9
17.0	23.8	23.6	23.4	23.8	23.7	23.6	23.5	23.5	23.4	23.5	23.6	23.5	23.5	23.5	23.2	23.3	23.4	23.5	23.3	23.3	23.3
16.0	24.6	24.6	24.5	24.5	24.3	24.4	24.4	24.4	24.3	24.3	24.3	24.2	24.3	24.2	24.2	24.1	24.2	24.1	24.0	24.1	23.7
15.0	25.2	25.1	25.3	25.3	25.2	25.2	25.2	25.1	25.1	25.2	25.2	25.2	25.2	25.1	24.9	25.0	25.0	24.8	24.8	24.9	24.7
14.0	26.0	26.1	26.2	25.9	26.1	26.0	26.0	26.0	26.0	26.1	25.8	26.0	26.0	26.0	25.8	25.7	25.8	25.7	25.8	25.7	25.8
13.0	26.8	27.0	26.9	26.9	26.9	26.9	26.9	26.9	26.9	26.8	26.9	26.9	26.9	26.8	26.7	26.7	26.6	26.6	26.8	26.5	26.8
12.0	28.0	28.1	28.0	28.1	27.9	27.9	28.0	27.9	27.9	27.8	27.8	27.9	27.8	27.9	27.8	27.7	27.7	27.6	27.7	27.6	27.3
11.0	29.3	29.4	29.4	29.2	29.2	29.1	29.1	29.1	28.9	29.0	29.0	28.7	28.9	28.8	28.8	28.7	28.8	28.7	28.6	28.6	28.6
10.5	30.0	30.0	30.0	29.9	29.8	29.6	29.7	29.6	29.5	29.6	29.4	29.5	29.3	29.3	29.2	29.2	29.3	29.2	29.2	29.1	29.0
10.0	31.4	31.8	31.7	30.8	31.0	30.8	30.4	30.2	30.2	30.1	30.0	30.1	30.0	30.0	29.9	29.9	30.1	29.9	29.8	29.7	29.6
9.5	34.7	36.4	37.5	34.9	33.6	34.5	32.9	31.5	31.0	31.0	30.9	30.7	30.7	30.8	30.6	30.5	30.6	30.5	30.5	30.4	30.1
9.0	44.0	45.3	42.7	40.1	39.9	37.6	34.4	32.6	32.1	31.8	31.7	31.6	31.6	31.4	31.3	31.2	31.4	31.3	31.2	31.2	31.3
8.5	55.4	54.8	53.1	52.7	50.6	45.2	40.6	39.6	35.6	33.5	32.7	32.6	32.4	32.3	32.1	32.1	32.1	32.1	32.0	32.0	31.8
8.0	68.4	67.2	68.3	65.4	60.2	52.8	51.8	48.2	41.5	36.2	34.0	33.5	33.4	33.1	33.4	33.0	33.1	32.9	33.1	32.9	32.8
7.5	89.8	85.4	84.5	84.7	80.3	72.3	67.4	64.2	56.1	47.6	40.4	36.4	34.9	34.7	34.5	34.4	34.5	34.3	34.5	34.1	34.3
7.0	107	103	103	102	95.6	87.2	83.9	76.0	65.4	56.3	48.1	41.2	38.2	36.8	35.9	35.6	35.6	35.5	35.4	35.5	35.5
6.5	131	123	122	123	119	109	105	98.2	85.3	75.4	66.0	56.7	49.1	45.1	40.2	38.2	37.6	37.2	37.1	37.1	37.1
6.0	149	144	144	145	136	129	124	113	100	90.3	80.7	70.1	61.3	56.5	49.4	43.3	41.5	41.8	41.2	40.0	39.7

810-005
101, Rev. D

Table 9. DSS 63 Eastern Horizon S-Band T_{op} (K) with SPD Cone

ELEV, deg	AZIMUTH, deg																				
	110	111	112	113	114	115	116	117	118	119	120	121	122	123	124	125	126	127	128	129	130
40.0	18.4	18.6	18.5	18.4	18.5	18.3	18.1	18.1	18.1	18.1	18.1	18.3	18.3	18.4	18.2	18.1	18.2	18.2	18.2	18.2	18.2
35.0	18.7	18.7	18.8	18.7	18.7	18.7	18.6	18.6	18.6	18.6	18.5	18.5	18.5	18.5	18.5	18.4	18.5	18.5	18.5	18.5	18.5
30.0	18.9	19.0	19.1	19.0	19.0	19.0	18.9	19.1	19.0	19.0	19.0	19.1	19.0	19.0	19.2	19.1	19.1	19.1	19.3	19.2	19.1
25.0	20.0	19.9	20.1	20.1	20.1	20.1	20.1	20.0	20.0	20.0	19.9	19.9	20.0	19.9	19.8	19.7	19.8	19.8	19.8	19.8	19.9
20.0	21.5	21.5	21.6	21.7	21.6	21.7	21.7	21.8	21.7	21.6	21.4	21.4	21.4	21.5	21.7	21.8	21.8	21.7	21.5	21.5	21.6
19.0	21.8	21.8	21.9	21.9	21.9	21.9	21.9	21.9	21.9	22.0	22.1	22.1	22.3	22.0	22.1	21.9	21.9	21.8	21.7	21.9	21.9
18.0	22.8	22.9	22.9	23.2	23.3	23.0	23.1	23.0	22.9	23.0	22.8	23.0	22.9	23.0	22.9	22.9	22.8	22.9	22.7	22.7	22.6
17.0	22.8	22.8	22.8	23.0	22.8	22.7	22.9	22.9	22.8	23.0	23.0	22.9	23.1	23.0	22.9	23.0	23.1	22.9	22.8	23.0	23.0
16.0	23.9	24.1	24.2	24.1	23.8	24.0	24.0	23.9	23.7	23.6	23.7	23.5	23.5	23.7	23.6	23.5	23.6	23.5	23.4	23.4	23.6
15.0	24.4	24.4	24.4	24.4	24.5	24.4	24.4	24.3	24.4	24.2	24.5	24.4	24.5	24.6	24.7	24.7	24.7	24.7	24.7	24.8	24.7
14.0	25.0	24.9	25.1	25.1	25.1	25.1	25.3	25.3	25.2	25.3	25.3	25.3	25.3	25.3	25.2	25.2	25.3	25.2	25.3	25.3	25.3
13.0	26.2	26.2	26.2	26.2	26.2	26.3	26.2	26.3	26.3	26.4	26.3	26.2	26.3	26.4	26.3	26.3	26.0	26.0	26.1	26.2	26.2
12.0	27.4	27.5	27.6	27.4	27.3	27.4	27.3	27.4	27.3	27.1	27.3	27.1	27.1	27.2	27.2	27.2	27.3	27.4	27.5	27.5	27.4
11.0	28.1	28.2	28.1	28.1	27.9	27.9	28.0	28.0	27.9	28.0	28.1	28.0	27.9	28.0	27.7	28.0	28.1	28.2	28.0	28.0	27.7
10.0	30.2	30.1	29.9	30.0	29.8	29.9	29.7	29.8	29.6	29.4	29.3	29.3	29.2	29.1	29.0	29.0	29.2	29.1	29.2	29.3	29.2
9.5	30.3	30.3	30.3	30.2	30.2	30.0	30.2	30.0	30.1	30.1	29.8	29.7	29.5	29.5	29.4	29.4	29.6	29.5	29.4	29.5	29.5
9.0	30.3	30.3	30.6	30.1	30.1	30.3	30.2	30.3	30.4	30.2	30.0	30.0	29.8	29.8	29.8	29.8	29.9	29.8	30.0	30.1	30.1
8.5	31.1	31.3	31.1	30.9	30.8	30.7	30.8	30.9	31.1	31.1	31.3	31.2	31.1	31.1	31.1	31.1	31.2	31.0	31.0	31.0	31.2
8.0	32.2	32.5	32.6	32.4	32.6	32.4	32.6	32.3	32.6	32.4	32.3	32.3	32.5	32.5	32.6	32.5	32.5	32.4	32.4	32.3	32.2
7.5	33.2	33.4	33.4	33.2	33.2	33.3	33.5	33.5	33.6	33.5	33.4	33.3	33.4	33.6	33.5	33.5	33.4	33.4	33.4	33.4	33.3
7.0	34.6	34.6	34.5	34.3	34.4	34.4	34.5	34.4	34.6	34.6	34.6	34.7	34.6	34.8	34.7	34.3	34.6	34.6	34.5	34.7	34.8
6.5	35.8	36.3	36.0	36.2	35.9	36.0	36.0	35.8	35.9	35.9	35.9	35.9	35.8	35.7	36.1	35.8	35.6	35.7	35.6	35.8	35.8
6.0	37.5	37.6	37.6	37.5	37.6	37.5	37.5	37.3	37.2	37.2	37.3	37.4	37.2	37.2	37.3	37.2	37.1	37.0	37.2	37.0	37.1
	AZIMUTH, deg																				
	130	131	132	133	134	135	136	137	138	139	140	141	142	143	144	145	146	147	148	149	150
40.0	18.2	18.3	18.3	18.3	18.3	18.3	18.4	18.4	18.4	18.1	18.0	18.1	18.1	18.2	18.2	18.4	18.5	18.5	18.3	18.3	
35.0	18.6	18.5	18.5	18.7	18.7	18.7	18.9	18.9	18.9	18.8	18.7	18.6	18.5	18.4	18.5	18.5	18.6	18.7	18.7	18.8	18.8
30.0	19.1	19.2	19.1	19.3	19.1	19.2	19.3	19.3	19.2	19.3	19.1	19.1	19.0	19.2	19.1	19.0	19.2	19.1	19.2	19.2	19.1
25.0	19.9	19.9	20.0	20.0	20.1	20.1	20.2	20.1	20.0	20.0	20.0	19.9	19.9	19.9	19.9	19.9	19.7	19.8	20.1	20.1	20.0
20.0	21.6	21.6	21.7	21.6	21.7	21.8	21.8	21.8	21.9	21.6	21.7	21.8	21.7	21.7	21.6	21.6	21.7	21.9	21.8	21.7	21.7
19.0	21.9	22.0	22.0	22.0	21.9	22.0	22.3	22.1	22.2	22.1	22.0	22.0	22.0	22.1	22.1	22.3	22.3	22.2	22.3	22.2	22.1
18.0	22.6	22.6	22.7	22.4	22.7	22.7	22.6	22.7	22.8	22.8	22.8	22.8	22.8	22.6	22.6	22.5	22.4	22.6	22.7	22.7	22.6
17.0	23.0	22.9	22.9	22.8	22.9	22.9	22.9	22.8	22.9	22.9	23.1	23.2	23.4	23.5	23.5	23.5	23.5	23.4	23.4	23.5	23.5
16.0	23.6	23.5	23.5	23.3	23.2	23.3	23.4	23.7	23.6	23.7	23.8	23.8	23.7	23.7	23.8	24.0	23.8	23.9	24.1	24.3	24.1
15.0	24.7	24.6	24.5	24.7	24.8	24.7	24.6	24.6	24.6	24.5	24.3	24.2	24.1	24.4	24.6	24.4	24.5	24.4	24.3	24.3	24.3
14.0	25.3	25.3	25.4	25.5	25.3	25.2	25.4	25.3	25.2	25.3	25.3	25.4	25.4	25.4	25.6	25.5	25.5	25.6	25.3	25.3	25.2
13.0	26.2	26.1	26.1	26.3	26.4	26.3	26.2	26.4	26.3	26.3	26.3	26.4	26.2	26.1	26.1	26.1	26.2	26.4	26.3	26.3	26.3
12.0	27.4	27.3	27.4	27.5	27.2	27.4	27.2	27.4	27.1	27.2	27.0	27.0	26.9	27.1	26.9	27.1	26.8	26.9	26.8	27.0	27.2
11.0	27.7	28.0	28.1	27.9	27.8	27.9	28.1	28.2	28.6	28.7	28.6	28.7	28.8	28.9	28.9	28.8	28.8	28.7	28.9	28.8	28.7
10.0	29.2	29.3	29.1	29.2	29.3	29.2	29.3	29.4	29.3	29.3	29.2	29.1	29.2	29.2	29.1	29.1	29.1	29.2	29.3	29.3	29.4
9.5	29.5	29.3	29.5	29.5	29.2	29.5	29.4	29.2	29.5	29.5	29.2	29.1	29.4	29.2	29.2	29.4	29.3	29.4	29.4	29.3	29.4
9.0	30.1	30.2	30.3	30.3	30.6	30.4	30.4	30.6	30.6	30.6	30.4	30.4	30.6	30.6	30.5	30.4	30.5	30.4	30.1	30.3	30.1
8.5	31.2	31.1	30.9	31.0	30.9	30.7	30.6	30.4	30.3	30.2	30.5	30.5	30.6	30.5	30.3	30.2	30.2	30.3	30.4	30.5	30.7
8.0	32.2	31.9	31.7	31.9	31.8	31.9	31.8	31.7	31.6	31.5	31.5	32.0	31.6	31.5	31.3	31.8	31.8	31.4	31.5	31.3	31.1
7.5	33.3	33.4	33.3	33.1	33.1	33.0	32.9	32.5	32.8	32.6	32.8	32.7	32.8	32.9	32.8	32.8	32.7	32.6	32.7	32.7	32.7
7.0	34.8	34.6	34.7	34.6	34.5	34.3	34.3	34.1	34.1	34.1	33.9	33.8	33.8	33.8	34.2	33.8	33.8	33.6	33.6	33.3	33.3
6.5	35.8	35.8	35.7	35.7	35.8	35.6	35.7	35.6	35.7	35.5	35.4	35.5	35.4	35.6	35.6	35.4	35.4	35.3	35.2	35.2	35.2
6.0	37.1	37.0	37.1	37.1	37.1	36.8	36.8	36.7	36.8	36.7	36.9	36.8	36.6	36.7	36.7	36.5	36.7	36.2	36.2	36.1	36.1

810-005
101, Rev. D

Table 10. DSS 63 Western Horizon S-Band T_{op} (K) with SPD Cone

ELEV, deg	AZIMUTH, deg																				
	210	211	212	213	214	215	216	217	218	219	220	221	222	223	224	225	226	227	228	229	230
40.0	26.2	20.4	19.6	19.7	19.4	19.6	20.2	20.5	21.6	26.6	22.3	20.2	19.6	19.5	19.1	19.1	19.2	19.2	19.3	19.2	19.1
35.0	19.5	19.5	19.9	19.8	20.0	20.2	20.4	20.7	22.0	25.8	21.6	20.6	20.3	20.1	19.9	19.8	19.7	19.7	19.6	19.7	19.7
30.0	20.4	20.6	20.7	20.9	21.0	21.8	24.2	22.9	21.9	21.5	21.0	20.8	20.8	20.7	20.6	20.5	20.5	20.5	20.4	20.4	20.2
25.0	21.2	21.3	21.2	21.5	21.7	23.0	26.6	24.4	22.6	22.1	21.8	21.5	21.3	21.4	21.2	21.1	21.1	21.1	21.1	21.1	20.9
20.0	22.9	23.4	23.7	24.0	25.5	26.4	24.6	23.8	23.5	23.1	23.0	22.7	22.8	22.7	22.6	22.4	22.4	22.4	22.6	22.7	22.5
19.0	23.5	23.6	23.8	24.3	25.7	27.4	25.5	24.6	24.0	23.6	23.3	23.2	23.4	23.0	23.2	23.0	23.0	22.9	22.9	23.0	22.9
18.0	24.3	25.0	28.2	30.5	26.1	25.3	24.5	24.2	23.8	23.7	23.6	23.6	23.5	23.6	23.4	23.4	23.4	23.4	23.4	23.4	23.5
17.0	24.8	25.0	27.3	27.3	26.8	25.7	24.9	24.7	24.5	24.2	24.2	24.1	24.0	24.0	24.0	24.0	24.0	24.0	23.9	24.0	23.9
16.0	25.8	27.2	28.0	26.6	25.7	25.4	24.9	24.7	24.6	24.6	24.5	24.8	24.8	24.8	24.6	24.7	24.6	24.6	24.7	24.7	24.5
15.0	27.1	27.8	29.8	27.6	27.3	26.4	25.7	25.5	25.6	25.4	25.3	25.6	25.3	25.3	25.3	26.0	27.6	25.5	25.1	25.2	25.0
14.0	29.5	35.3	28.7	26.9	26.6	26.3	26.3	26.0	26.2	26.0	26.1	26.1	26.0	26.1	26.2	26.0	26.0	26.0	26.1	26.0	26.1
13.0	35.0	42.1	30.3	28.1	27.5	27.4	27.0	26.8	27.0	26.8	26.8	26.9	26.7	26.8	26.9	27.0	26.9	26.8	26.9	26.8	26.8
12.0	30.7	29.6	28.6	28.2	27.9	27.9	27.7	27.5	27.7	27.5	27.5	27.5	27.5	27.5	27.5	27.6	27.7	27.8	27.7	27.8	27.8
11.0	31.3	30.8	29.8	29.2	28.9	28.7	28.4	28.4	28.6	28.5	28.5	28.6	28.5	28.5	28.5	28.4	28.4	28.7	28.6	28.6	28.6
10.0	29.8	29.9	29.8	29.6	29.5	29.4	29.3	29.4	29.3	29.4	29.5	29.4	29.3	29.7	29.5	29.5	29.4	29.5	29.5	29.7	29.7
9.5	30.6	30.4	30.2	30.3	30.1	30.1	30.1	30.1	30.2	30.1	30.3	30.3	30.0	30.0	30.6	30.3	30.1	30.3	30.4	30.2	30.2
9.0	30.9	30.9	30.8	30.7	30.9	30.6	30.8	30.7	30.8	30.7	31.1	30.8	30.7	30.7	30.9	30.8	30.9	30.7	31.1	30.8	31.0
8.5	31.5	31.5	31.4	31.6	31.7	31.5	31.4	31.5	31.4	31.4	31.3	31.3	31.2	31.2	31.3	31.3	31.2	31.4	31.3	31.3	31.3
8.0	32.3	32.1	31.9	32.3	32.1	32.1	32.2	31.9	32.4	32.2	32.3	32.2	32.4	32.3	32.0	32.2	32.4	32.4	32.4	32.5	32.5
7.5	33.1	33.2	32.9	33.5	33.0	33.0	33.3	33.0	32.9	33.4	33.2	33.3	33.2	33.1	33.4	33.5	33.2	33.3	33.2	33.2	33.5
7.0	33.9	34.5	33.8	34.3	34.3	34.1	34.0	34.0	34.3	34.3	34.6	34.3	34.3	34.5	34.7	34.8	34.6	34.7	34.7	34.5	34.5
6.5	34.4	34.2	34.7	34.8	34.7	34.8	34.4	34.5	34.4	34.8	34.5	34.9	34.8	34.7	35.0	35.2	35.2	35.3	35.2	35.2	35.4
6.0	35.4	35.3	35.7	36.2	35.5	35.9	35.8	35.8	36.1	36.6	36.7	36.3	36.8	36.9	36.9	37.0	37.1	36.9	37.2	37.3	37.1
	AZIMUTH, deg																				
	230	231	232	233	234	235	236	237	238	239	240	241	242	243	244	245	246	247	248	249	250
40.0	19.1	19.0	18.9	18.9	18.9	18.8	18.8	18.8	18.9	18.8	18.8	18.9	18.9	18.9	18.9	18.9	18.9	18.9	18.9	18.9	19.0
35.0	19.7	19.5	19.6	19.4	19.3	19.5	19.4	19.3	19.5	19.4	19.2	19.2	19.4	19.4	19.2	19.1	19.2	19.3	19.4	19.2	19.2
30.0	20.2	20.3	20.2	20.2	20.3	20.2	20.2	20.1	20.1	20.0	20.1	20.0	19.9	20.0	20.0	20.1	20.1	20.0	20.2	20.2	20.2
25.0	20.9	20.9	21.2	21.1	20.8	20.9	20.9	20.9	20.9	20.9	21.0	21.0	21.0	21.0	21.1	21.1	21.1	21.1	21.1	21.1	21.0
20.0	22.5	22.6	22.7	22.5	22.6	22.6	22.5	22.9	22.7	22.7	22.6	22.5	22.5	22.5	22.6	22.6	22.6	22.6	22.6	22.7	22.8
19.0	22.9	23.0	23.0	23.0	23.0	23.0	23.0	23.0	23.0	23.2	23.1	23.2	23.2	23.1	23.1	23.1	23.1	23.1	23.2	23.2	23.2
18.0	23.5	23.5	23.5	23.5	23.6	23.6	23.7	23.7	23.7	23.8	23.8	23.9	23.8	23.7	23.7	23.7	23.7	23.7	23.8	23.8	23.8
17.0	23.9	23.9	24.1	24.1	24.1	24.1	24.1	24.1	24.3	24.3	24.3	24.3	24.2	24.2	24.2	24.2	24.2	24.2	24.2	24.3	24.3
16.0	24.5	24.6	24.7	24.7	24.7	24.8	24.8	24.8	24.8	24.9	24.7	24.7	24.6	24.6	24.7	24.8	24.9	24.8	24.9	24.9	24.9
15.0	25.0	25.2	25.2	25.2	25.1	25.3	25.2	25.3	25.3	25.3	25.6	25.4	25.5	25.5	25.5	25.6	25.6	25.6	25.5	25.7	25.6
14.0	26.1	26.0	26.1	26.1	26.2	26.2	26.2	26.3	26.2	26.3	26.4	26.3	26.3	26.3	26.4	26.4	26.4	26.5	26.6	26.5	26.6
13.0	26.8	26.9	26.8	26.8	26.8	26.9	26.9	26.9	26.9	27.0	27.0	27.0	27.1	27.1	27.1	27.1	27.1	27.1	27.2	27.2	27.3
12.0	27.8	27.6	27.7	27.7	27.8	27.8	27.8	27.8	27.9	28.0	27.9	27.9	27.9	27.9	28.0	28.0	28.0	28.1	28.1	28.2	28.2
11.0	28.6	28.6	28.5	28.5	28.6	28.5	28.6	28.8	28.7	28.7	28.9	28.8	28.8	28.8	28.8	28.9	28.9	28.9	28.9	29.0	29.0
10.0	29.7	29.5	29.5	29.5	29.6	29.6	29.6	29.7	29.8	29.9	29.8	29.8	29.9	29.9	30.0	30.0	30.0	30.0	30.1	30.1	30.1
9.5	30.2	30.4	30.3	30.3	30.3	30.3	30.2	30.5	30.4	30.4	30.6	30.5	30.6	30.6	30.6	30.7	30.8	30.7	30.6	30.7	30.7
9.0	31.0	30.8	31.0	30.9	31.1	31.0	31.0	31.1	31.1	31.3	31.2	31.3	31.4	31.3	31.4	31.4	31.4	31.4	31.4	31.5	31.6
8.5	31.3	31.3	31.5	31.5	31.4	31.5	31.6	31.7	31.6	31.8	31.8	32.0	31.8	31.9	32.1	32.0	32.2	32.2	32.3	32.3	32.4
8.0	32.5	32.4	32.5	32.4	32.3	32.5	32.7	32.7	32.8	32.9	32.8	32.9	32.9	33.0	32.9	33.0	33.1	33.2	33.3	33.3	33.5
7.5	33.5	33.3	33.1	33.3	33.4	33.5	33.6	33.6	33.8	33.9	34.0	33.9	34.1	34.3	34.2	34.7	34.5	34.6	34.5	34.6	34.7
7.0	34.5	34.6	34.5	34.5	34.5	34.7	34.5	34.6	34.7	34.9	35.1	35.4	35.4	35.5	35.6	35.8	36.1	36.3	36.5	36.4	36.5
6.5	35.4	35.4	35.4	35.7	36.0	35.9	36.0	35.8	35.3	35.7	35.8	36.2	36.5	36.8	37.2	37.9	39.0	42.3	45.9	44.5	39.2
6.0	37.1	37.2	37.1	37.0	37.3	37.3	37.2	37.5	37.5	37.9	38.4	39.2	41.6	47.5	49.4	57.4	89.6	113	122	118	105

Deep Space Network (DSN)

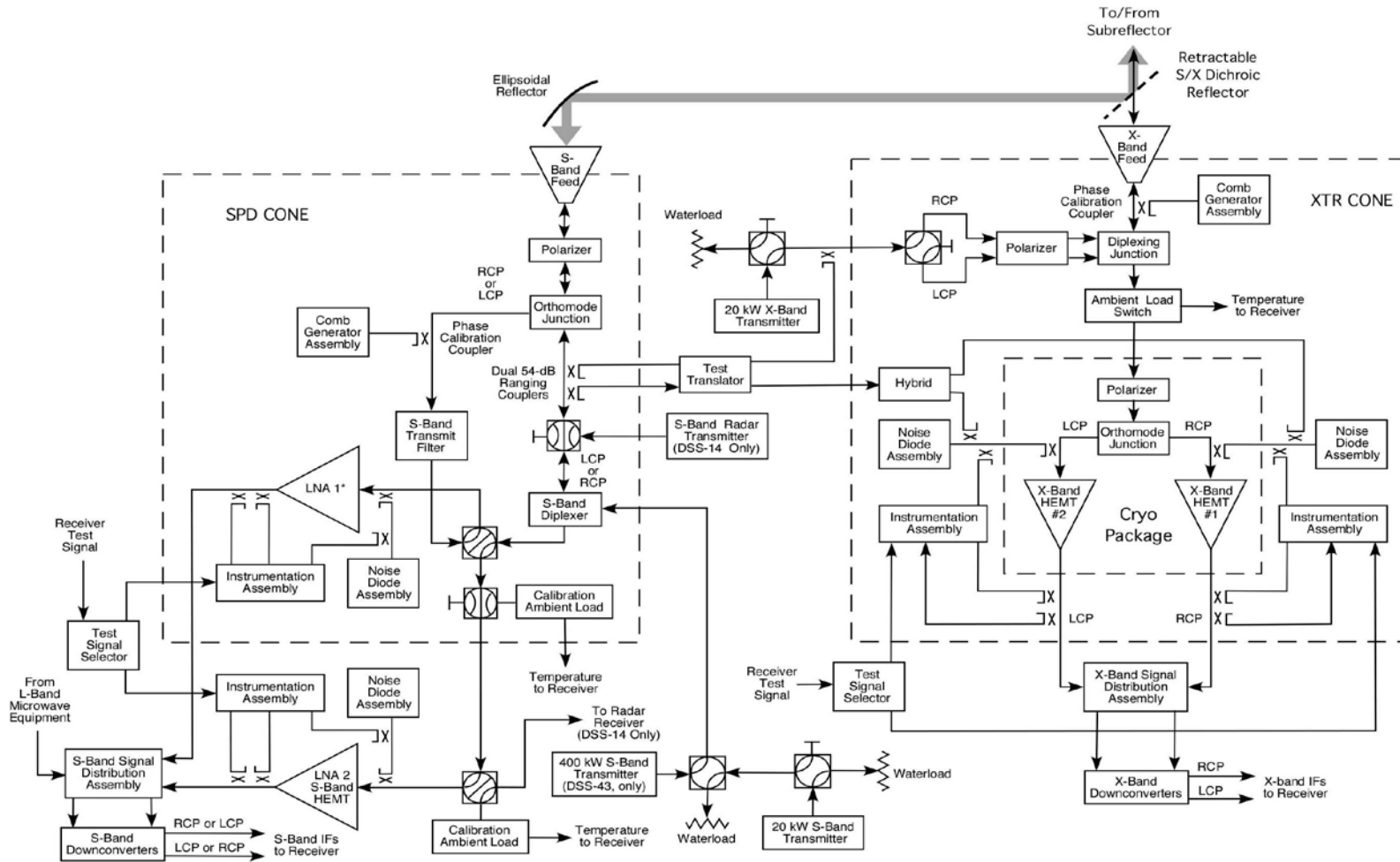

*Note: See text for type of LNA used for S-band LNA 1.

Figure 1. Functional Block Diagram of S-Band and X-Band Microwave and Transmitter Equipment

Deep Space Network (DSN)
Telecommunications Link Design Handbook

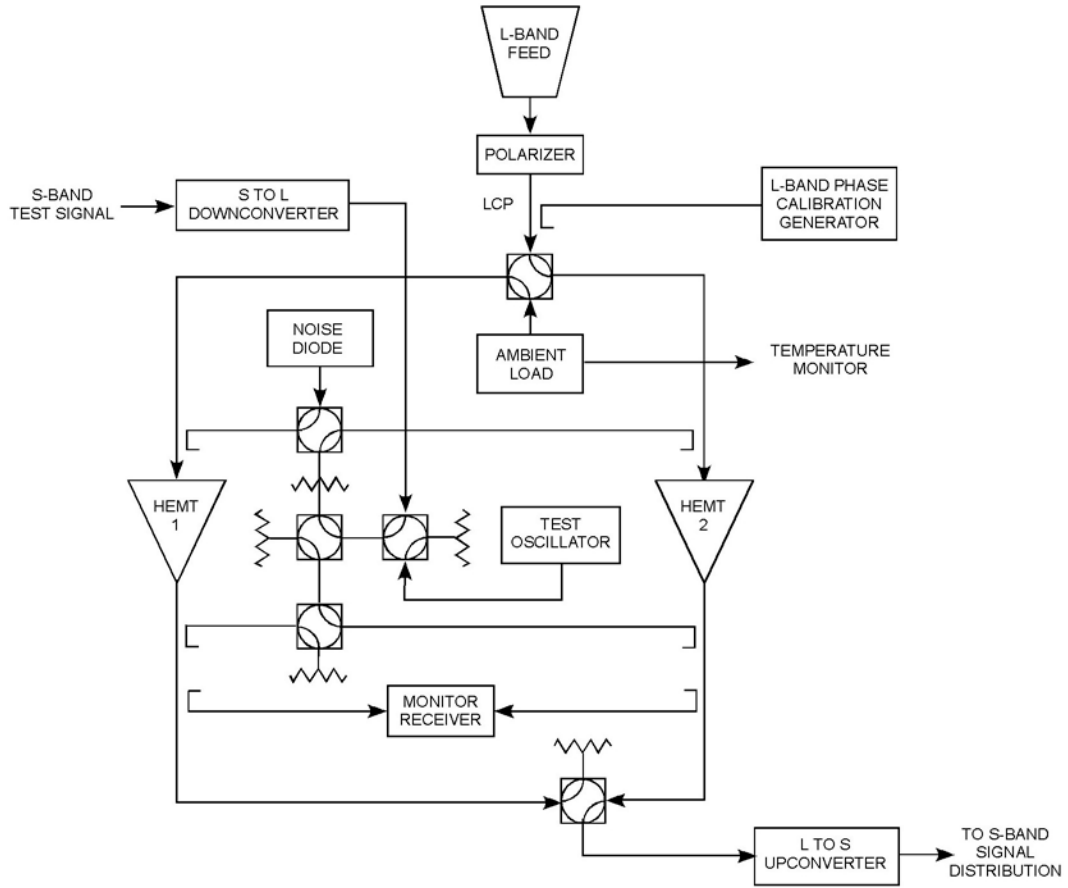

Figure 2. Functional Block Diagram of L-Band Microwave Equipment

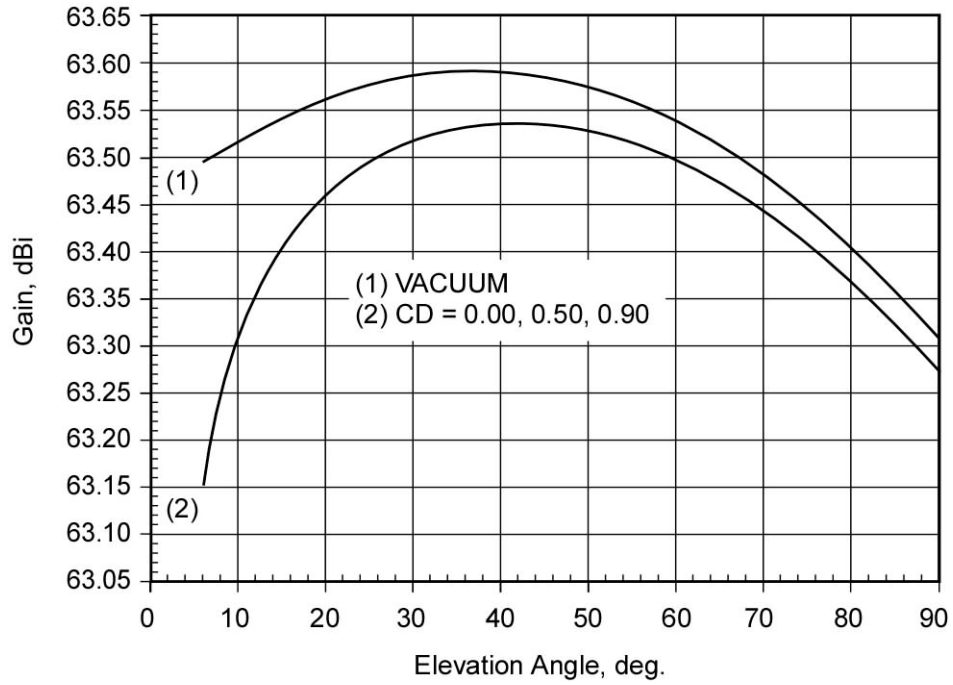

Figure 3. S-Band Receive Gain, All Stations, at Feedhorn Aperture

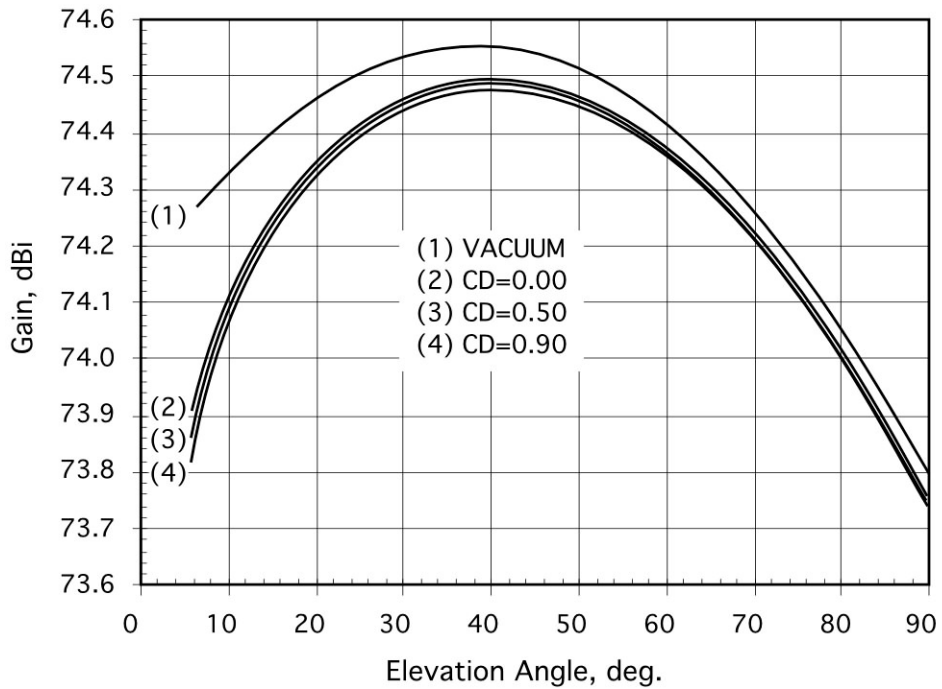

Figure 4. X-Band Receive Gain, DSS 14 Antenna, X-Only Configuration (S/X Dichroic Retracted), at Feedhorn Aperture

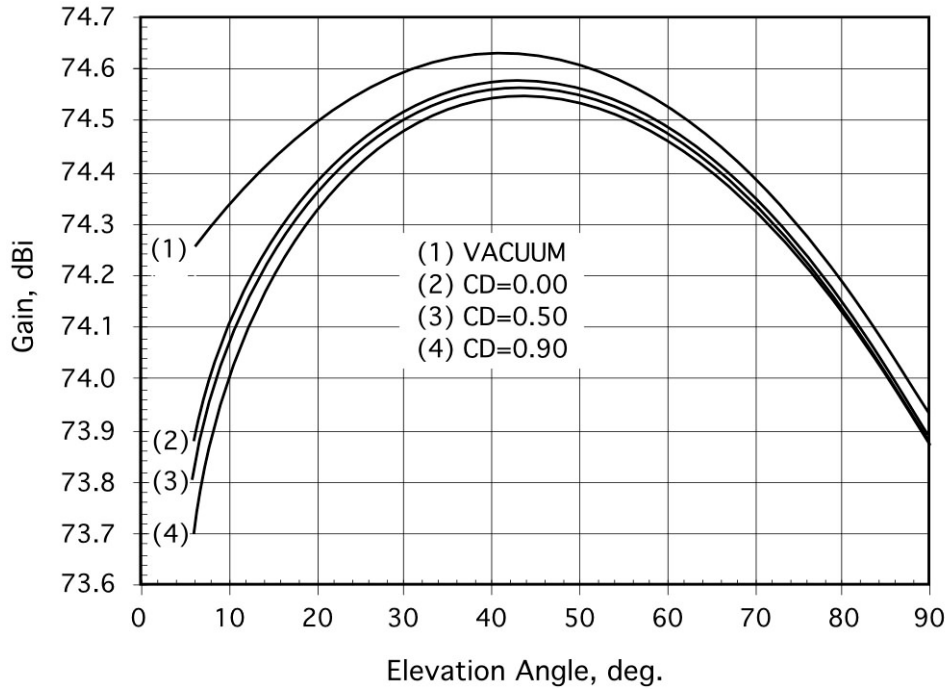

Figure 5. X-Band Receive Gain, DSS 43 Antenna, X-Only Configuration (S/X Dichroic Retracted), at Feedhorn Aperture

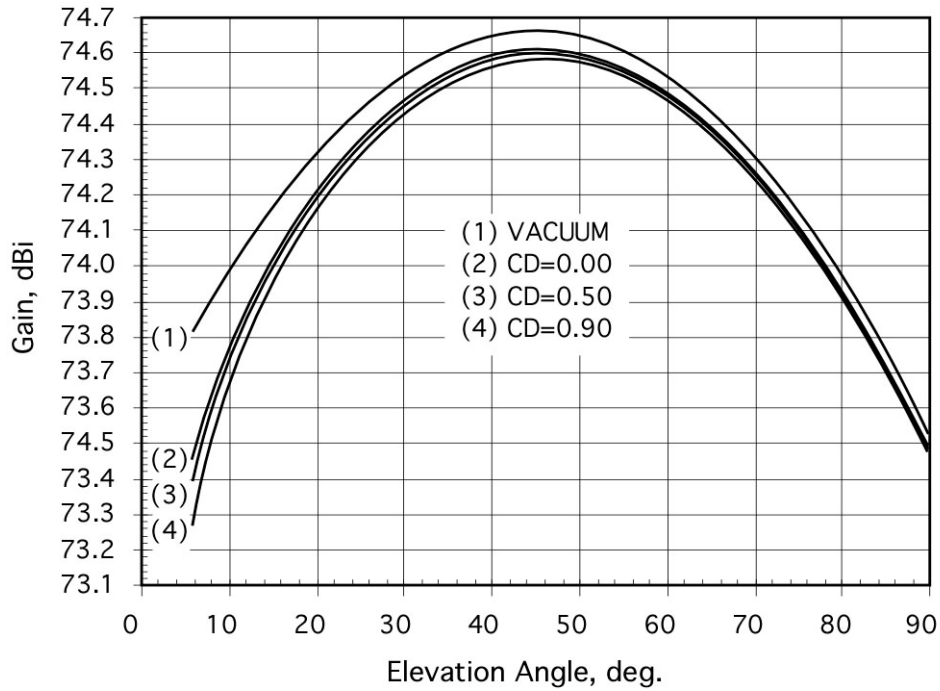

Figure 6. X-Band Receive Gain, DSS 63 Antenna, X-Only Configuration (S/X Dichroic Retracted), at Feedhorn Aperture

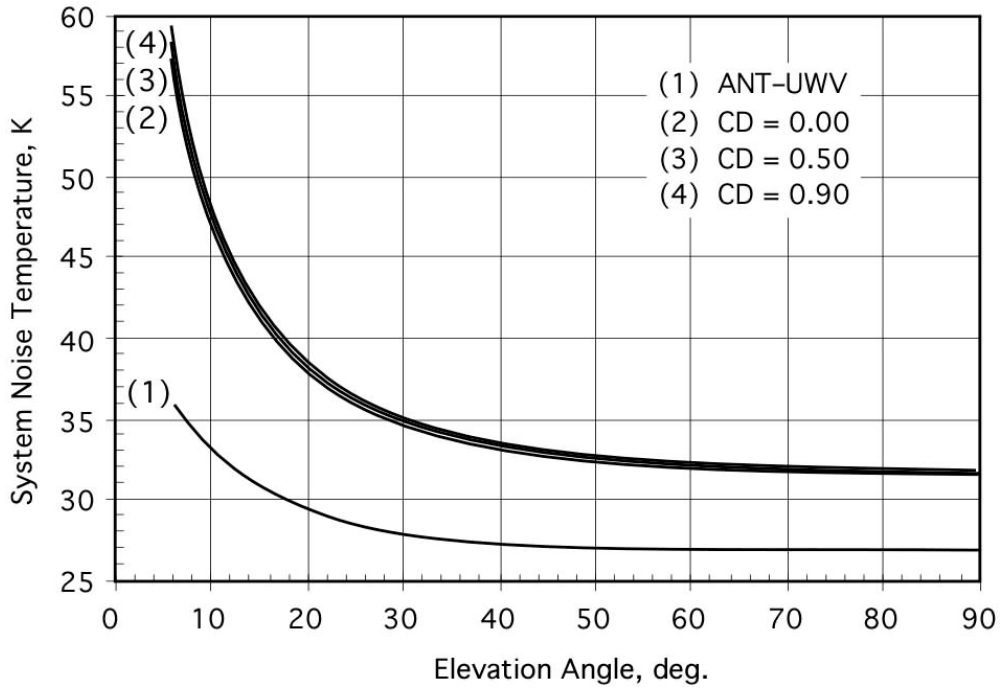

Figure 7. L-Band System Noise Temperature, All Stations, at Feedhorn Aperture

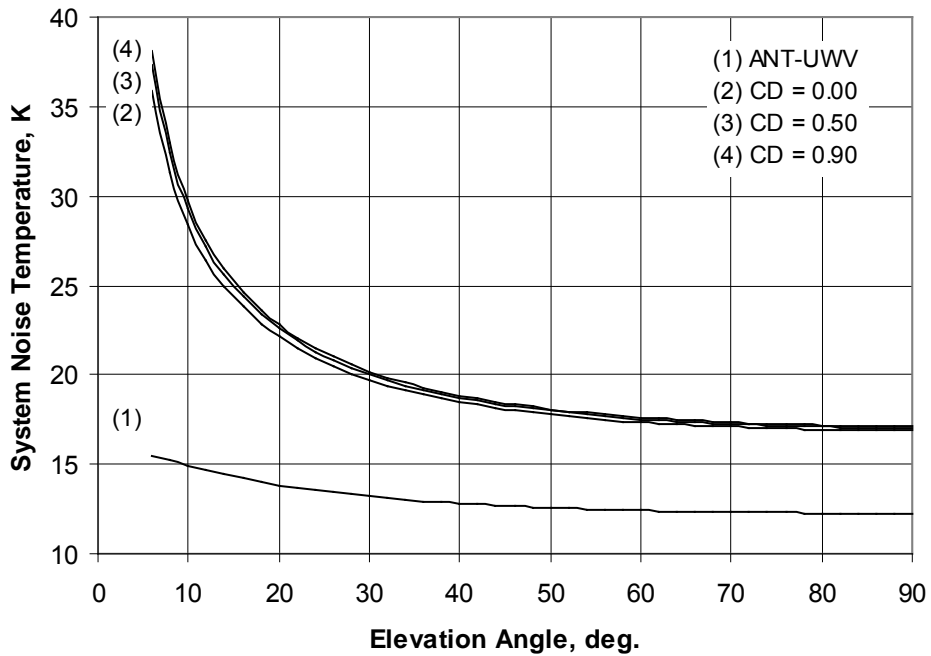

Figure 8. S-Band System Noise Temperature, DSS 14 Antenna, LNA-1, Non-Diplexed, at Feedhorn Aperture

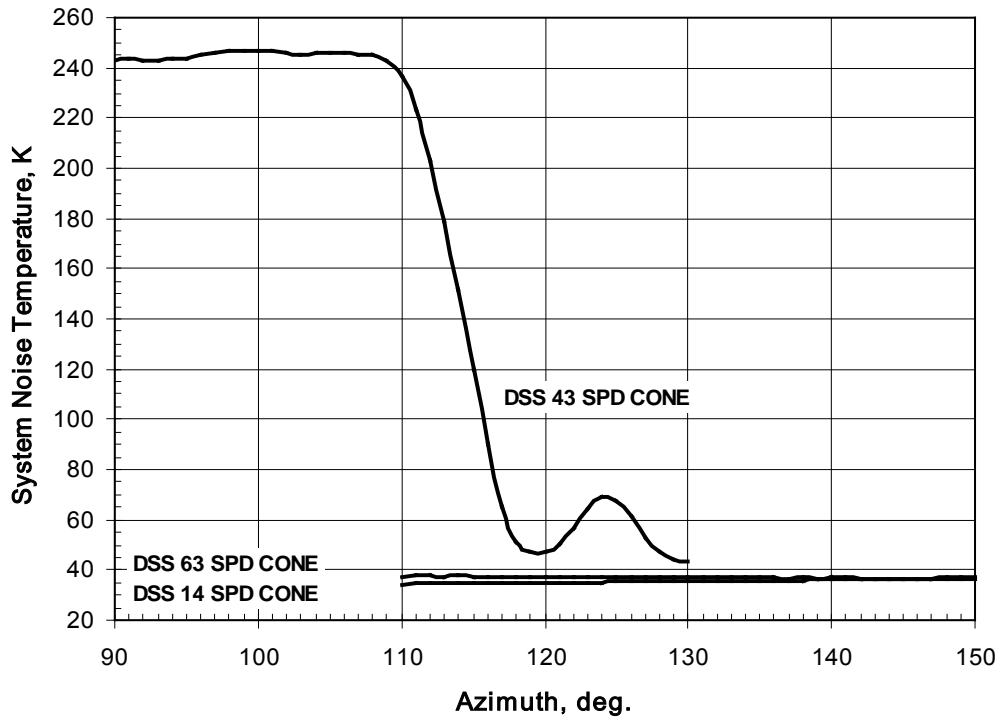

Figure 9. Eastern Horizon S-Band System Noise Temperature at 6° Elevation Angle

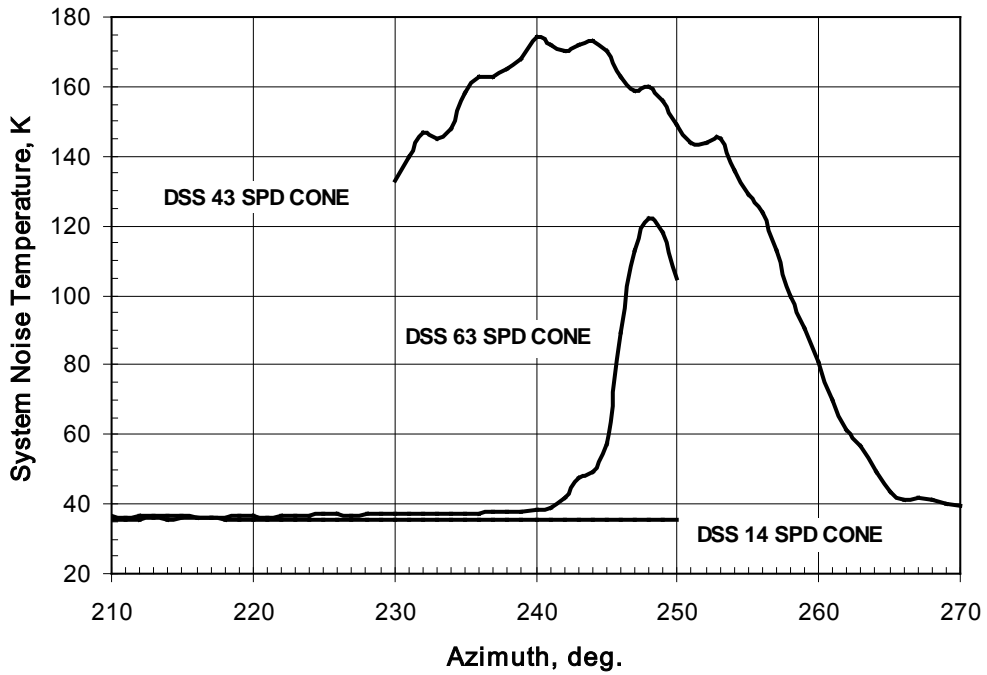

Figure 10. Western Horizon S-Band System Noise Temperature at 6° Elevation Angle

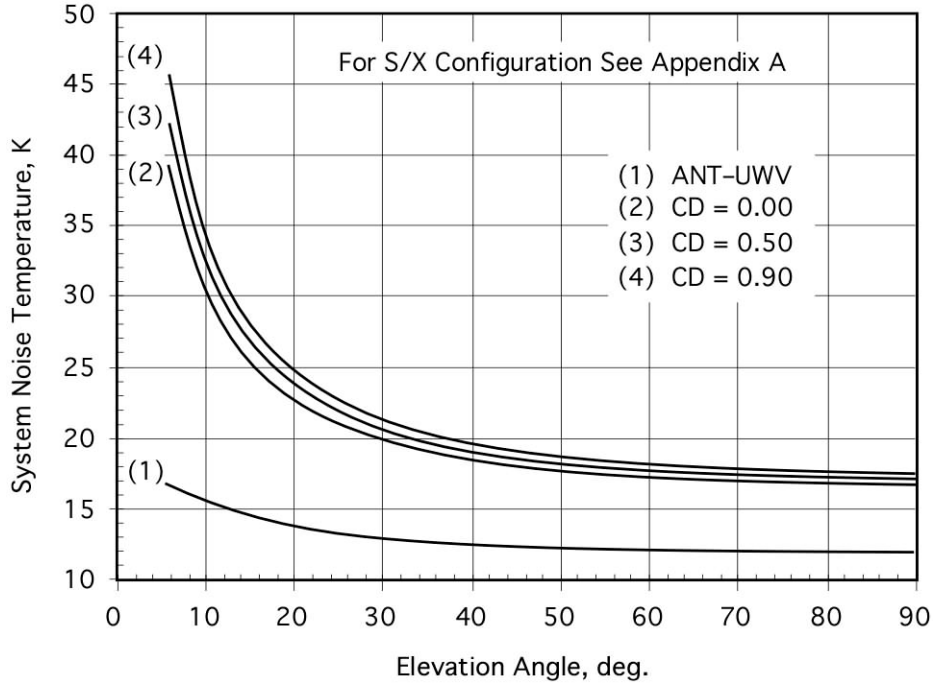

Figure 11. X-Band System Noise Temperature, DSS 14 Antenna, LNA-1 or LNA-2, X-Only Configuration (S/X Dichroic Retracted)

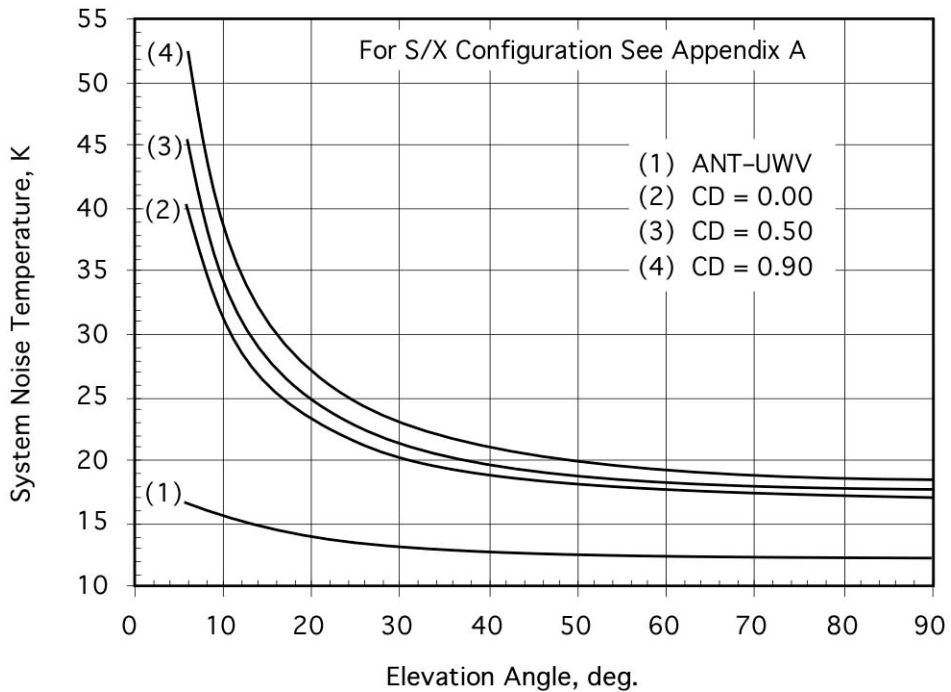

Figure 12. X-Band System Noise Temperature, DSS 43 Antenna, LNA-1 or LNA-2, X-Only Configuration (S/X Dichroic Retracted)

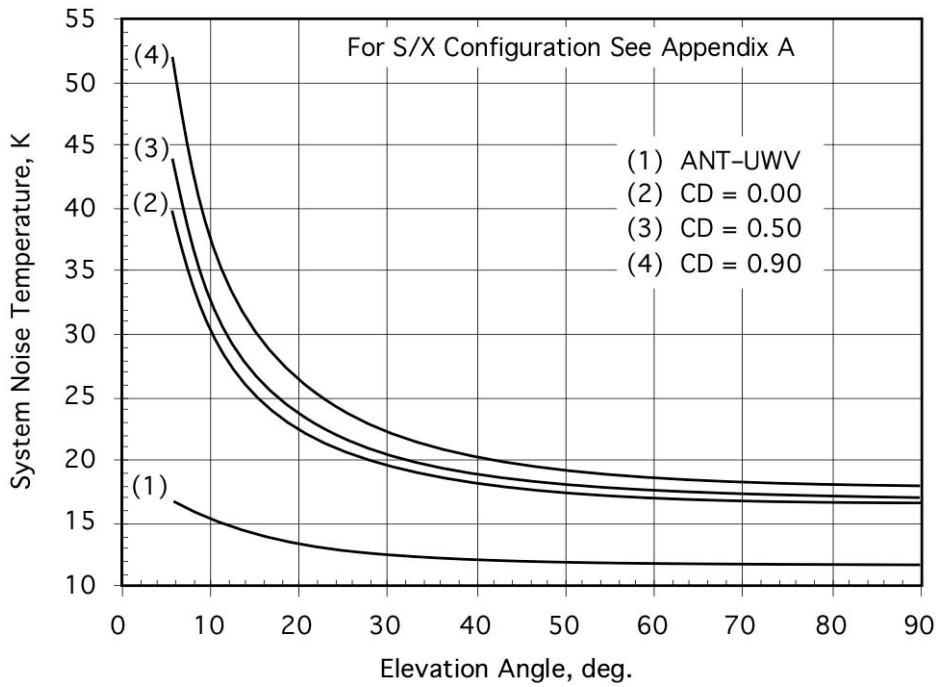

Figure 13. X-Band System Noise Temperature, DSS 63 Antenna, LNA-1 or LNA-2, X-Only Configuration (S/X Dichroic Retracted)

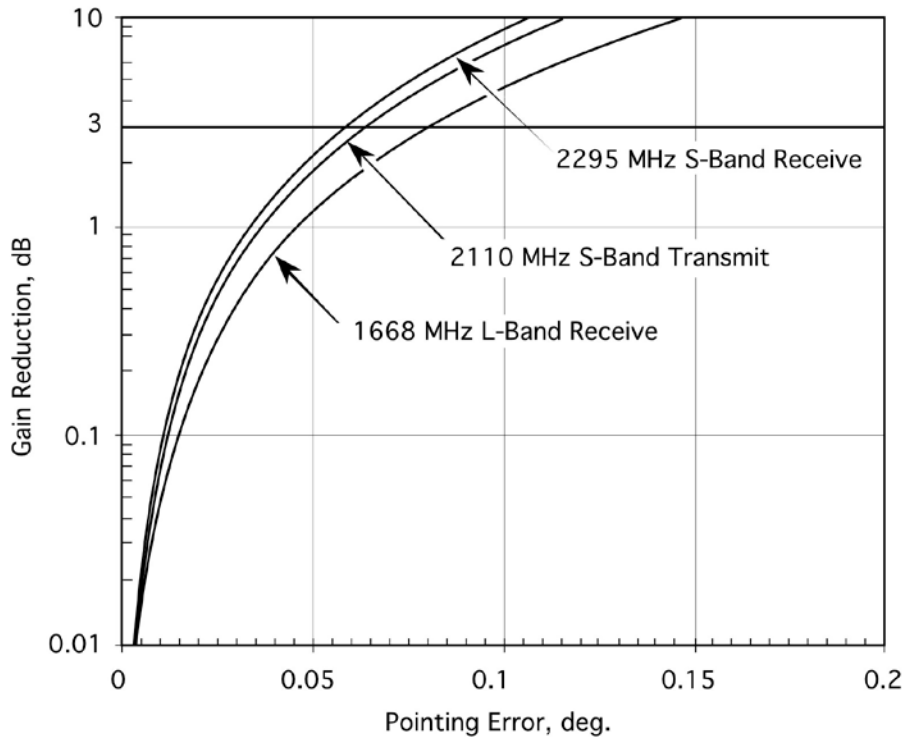

Figure 14. L-Band and S-Band Pointing Loss Versus Pointing Error

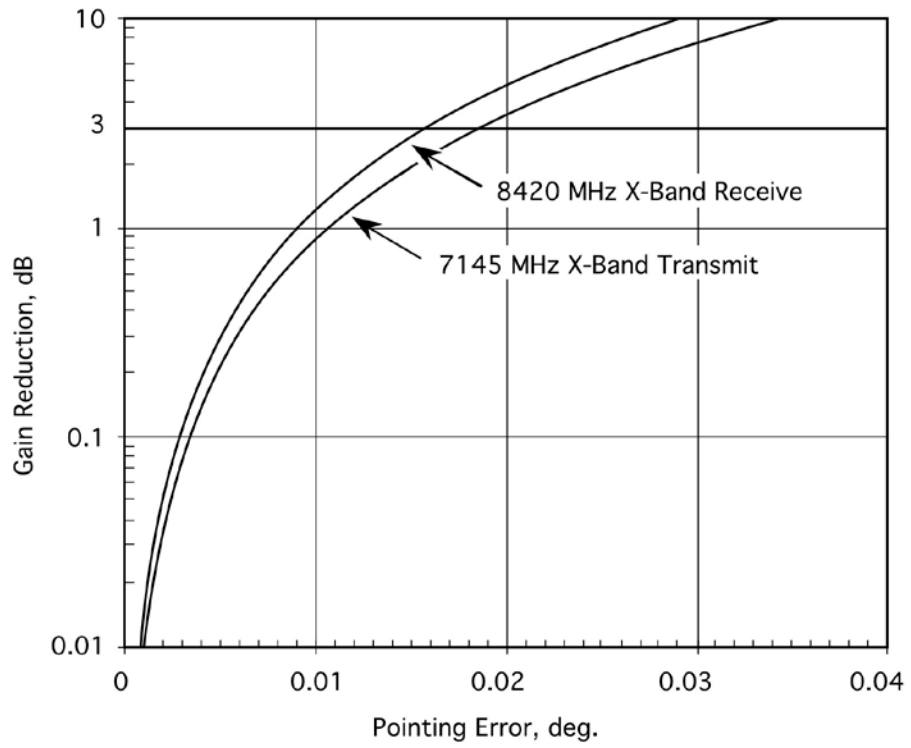

Figure 15. X-Band Pointing Loss Versus Pointing Error

Appendix A ***Equations for Modeling***

A.1 Equations for Gain Versus Elevation Angle

The following equation can be used to generate L-band receive, and S- and X-band transmit and receive gain versus elevation curves for DSS 14, DSS 43, and DSS 63. The gains are referenced to feedhorn aperture so different configurations (e.g., LNA-1 non-diplexed and LNA-2 diplexed) will have the same gain values. Examples of these curves are shown in Figures 3 through 6, for S- and X-bands. See paragraph 2.1.1.1 for frequency effect modeling and Module 105, Rev. B for atmospheric attenuation at weather conditions corresponding to cumulative distributions from 0% to 99%. The year-average atmosphere attenuations for CD = 0.00, 0.50, and 0.90 are also given in Table A-2.

$$G(\theta) = G_0 - G_1(\theta - \gamma)^2 - \frac{A_{ZEN}}{\sin \theta}, \text{ dBi} \quad (\text{A1})$$

where

- θ = antenna elevation angle (deg.) $6 \leq \theta \leq 90$
- G_0, G_1, γ = parameters from Table A-1
- A_{ZEN} = zenith atmospheric attenuation from Table A-2 or from Tables 10 through 15 in Module 105, dB.

A.2 Equations for System Noise Temperature Versus Elevation Angle

The following equations can be used to generate L-, S-, and X-band receive system noise temperature versus elevation curves for DSS 14, DSS 43, and DSS-63. Examples of these curves are shown in Figures 7, 8, and 11 through 13. See Module 105, Rev. B for atmospheric attenuation at weather conditions corresponding to cumulative distributions from 0% to 99%. Atmosphere attenuations for CD = 0.00, 0.50, and 0.90 are also given in Table A-2.

System operating noise temperature:

$$T_{op}(\theta) = T_{AMW} + T_{sky} = \left[T_1 + T_2 e^{-a\theta} \right] + \left[T_{atm}(\theta) + T'_{CMB}(\theta) \right] \quad (\text{A2})$$

Sky noise contribution:

$$T_{sky} = T_{atm}(\theta) + T'_{CMB}(\theta) \quad (\text{A3})$$

Atmospheric attenuation:

$$A(\theta) = \frac{A_{zen}}{\sin(\theta)}, \text{ dB} \quad (\text{A4})$$

Atmospheric loss factor:

$$L(\theta) = 10^{\frac{A(\theta)}{10}}, \text{ dimensionless, } > 1.0 \quad (\text{A5})$$

Atmospheric physical temperature:

$$T_p = 255 + 25 \times CD, \text{ K} \quad (\text{A6})$$

Atmospheric noise contribution:

$$T_{atm}(\theta) = T_p \left[1 - \frac{1}{L(\theta)} \right], \text{ K} \quad (\text{A7})$$

Effective cosmic background noise:

$$T'_{CMB}(\theta) = \frac{T_{CMB}}{L(\theta)}, \text{ K} \quad (\text{A8})$$

where

- θ = antenna elevation angle (deg.), $6 \leq \theta \leq 90$
- T_1, T_2, a = antenna-microwave noise temperature parameters from Table A-3
- A_{ZEN} = zenith atmospheric attenuation, dB, from Table A-2 or from Tables 10 through 15 (L-, S-, X-bands) in Module 105, Rev. B, as a function of frequency, station, and cumulative distribution (CD)
- CD = cumulative distribution, $0 \leq CD \leq 0.99$, used to select A_{ZEN} from Table A-2 or from Tables 10 through 15 in Module 105, Rev. B
- T_{CMB} = 2.725 K, cosmic microwave background noise temperature

A.3 *Equation for Gain Reduction Versus Pointing Error*

The following equation can be used to generate gain-reduction versus pointing error curves, examples of which are depicted in Figures 14 and 15.

$$\Delta G(\theta) = 10 \log \left(e^{\frac{2.773\theta^2}{HPBW^2}} \right), \text{ dBi} \quad (\text{A9})$$

where

θ = pointing error (deg.)

$HPBW$ = half-power beamwidth in degrees (from Tables 1 or 2).

Table A-1. Vacuum Component of Gain Parameters, Referenced to Feedhorn Aperture

Configuration and Stations	Parameters†			
	G_0 (Transmit)	G_0 (Receive)	G_1	γ
L-Band, All Stations	—	61.04	0.000084	45
S-Band, All Stations	62.95	63.59	0.0001	37
X-Band, X-only Configuration				
DSS 14	73.17	74.55	0.000285	38.35
DSS 43	73.25	74.63	0.000300	41.53
DSS 63	73.28	74.66	0.000560	44.93
X-Band, S/X Configuration				
DSS 14	72.97	74.35	0.000365	44.19
DSS 43	72.98	74.36	0.000300	41.53
DSS 63	72.81	74.19	0.000550	45.57

Notes:

† G_0 values are nominal at the frequency specified in Table 1 or Table 2. Other parameters apply to all frequencies within the same band.

Table A-2. Zenith Year-Average Atmosphere Attenuation Above Vacuum (A_{ZEN})

Weather Condition†	A_{ZEN} , dB*				
	L-Band	S-Band	X-Band		
	All Stations	All Stations	DSS 14	DSS 43	DSS 63
Vacuum	0.000	0.000	0.000	0.000	0.000
CD = 0.00	0.035	0.035	0.037	0.039	0.038
CD = 0.50	0.035	0.035	0.041	0.047	0.044
CD = 0.90	0.036	0.036	0.046	0.058	0.057

Notes:

* From Tables 10 through 15 in Module 105, Rev. B. L- and S-band values are averages for all stations.

† CD = cumulative distribution.

Table A-3. Antenna-Microwave Noise Temperature Parameters, Referenced to Feedhorn Aperture

Configuration and Stations	Parameters		
	T_1	T_2	a
L-band , all stations, LNA-1 or -2, HEMT, LCP, non-diplexed	26.67	15.66	0.09
S-band , DSS 14, SPD cone, LNA-1, HEMT, non-diplexed	12.19	4.49	0.05
S-band , DSS 14, SPD cone, LNA-1, HEMT, diplexed	16.74	4.55	0.05
S-band , DSS 14, Mod III, LNA-2, HEMT, non-diplexed	18.74	4.61	0.05
S-band , DSS 14, Mod III, LNA-2, HEMT, diplexed	23.69	4.67	0.05
S-band , DSS 43, SPD cone, LNA-1, maser, non-diplexed	11.29	21.95	0.14
S-band , DSS 43, SPD cone, LNA-1, maser, diplexed	16.00	22.26	0.14
S-band , DSS 43, Mod III, LNA-2, HEMT, non-diplexed	19.59	22.51	0.14
S-band , DSS 43, Mod III, LNA-2, HEMT, diplexed	24.72	22.83	0.14
S-band , DSS 63, SPD cone, LNA-1, maser, non-diplexed	10.67	4.70	0.057
S-band , DSS 63, SPD cone, LNA-1, maser, diplexed	15.78	4.76	0.057
S-band , DSS 63, Mod III, LNA-2, HEMT, non-diplexed	21.20	4.82	0.057
S-band , DSS 63, Mod III, LNA-2, HEMT, diplexed	26.82	4.88	0.057
X-band , DSS 14, LNA-1, HEMT, RCP, X-only configuration	11.63	7.11	0.065
X-band , DSS 14, LNA-2, HEMT, LCP, X-only configuration	11.63	7.11	0.065
X-band , DSS 14, LNA-1, HEMT, RCP, S/X configuration	12.57	7.11	0.065
X-band , DSS 14, LNA-2, HEMT, LCP, S/X configuration	12.57	7.11	0.065
X-band , DSS 43, LNA-1, HEMT, RCP, X-only configuration	12.09	6.76	0.070
X-band , DSS 43, LNA-2, HEMT, LCP, X-only configuration	12.09	6.76	0.070
X-band , DSS 43, LNA-1, HEMT, RCP, S/X configuration	13.32	10.49	0.100
X-band , DSS 43, LNA-2, HEMT, LCP, S/X configuration	13.32	10.49	0.100
X-band , DSS 63, LNA-1, HEMT, RCP, X-only configuration	11.45	8.07	0.077
X-band , DSS 63, LNA-2, HEMT, LCP, X-only configuration	11.45	8.07	0.077
X-band , DSS 63, LNA-1, HEMT, RCP, S/X configuration	12.62	4.84	0.060
X-band , DSS 63, LNA-2, HEMT, LCP, S/X configuration	12.62	4.84	0.060