



Deep Space Network

104

34-m BWG Stations

Telecommunications Interfaces

Document Owner:

Signature Provided 01/19/2017

Stephen D. Slobin Date
Antenna System Engineer

Prepared by:

Signature Provided 01/19/2017

Stephen D. Slobin Date
Antenna System Engineer

Approved by:

Signature Provided 01/19/2017

Timothy T. Pham Date
Communications Systems Chief
Engineer

Released by:

Signature Provided 02/10/2017

C. Chang Date
DSN Document Release Authority

DSN No. **810-005, 104, Rev. I**
Issue Date: February 10, 2017
JPL D-19379; CL#17-0699

Jet Propulsion Laboratory
California Institute of Technology

Users must ensure that they are using the current version in DSN Telecommunications Link Design Handbook website:
<http://deepspace.jpl.nasa.gov/dsndocs/810-005/>

© <2017> California Institute of Technology.
U.S. Government sponsorship acknowledged.

Review Acknowledgment

By signing below, the signatories acknowledge that they have reviewed this document and provided comments, if any, to the signatories on the Cover Page.

Signature Provided	01/17/2017	Signature Not Provided	
_____	_____	_____	_____
Jeff Berner DSN Project Chief Engineer	Date	David Rochblatt Antenna System Engineer	Date
Signature Provided	11/21/2016		
_____	_____		
Timothy Cornish Uplink System Engineer	Date		

Document Change Log

Rev	Issue Date	Prepared By	Affected Paragraphs	Change Summary
Initial	11/30/2000	S. Slobin R. Sniffin	All	All
A	2/5/2004	S. Slobin R. Sniffin	All	Added performance information for Ka-band capability at DSS-26 and for new station, DSS-55. Incorporated latest measurements for other stations. Incorporated text improvements.
B	8/1/2005	S. Slobin R. Sniffin	Tables 4, 5, A-1, A-2, A-3, Figures 4, 9, 14, 20, and 25.	Revised performance information for DSS-34 to reflect addition of Ka-band and X-band improvements. Required splitting of Table 4 into Tables 4 and 5, renumbering subsequent tables, revision of Figures 9 and 20, and addition of Figures 4, 14, and 25.
C	9/19/2008	S. Slobin R. Sniffin	Sections 2.1.3, 3.0; All Tables; Figures 1, 3, 4, 6 - 27	Documents installation of an X-band acquisition capability at DSS-24, -34, and -54. Revised T_{AMW} formulation for noise temperature to be consistent with Rev. B of module 105. Added proposed 26 GHz capability at DSS-24, -34, and -54.
D	5/15/2009	S. Slobin R. Sniffin	Tables 6, 11 Figures 13-15, 27-29, 36 Table A-3	Add K-band gain and noise temperature performance for DSS-24, -34, and -54.
E	9/15/2009	S. Slobin	Table A-4	Updated Ka-band G and T parameters for DSS-54 and DSS-55. HEMT numbering has also been corrected in that Table.
F	6/1/2010	S. Slobin	Table 6 Table 11 Figures 27, 28, 29 Table A-3	New K-band receive Tamw values New K-band receive Tamw and Top values New figures for K-band New K-band Tamw parameters Eliminated the Rev. E designation for the document series

Rev	Issue Date	Prepared By	Affected Paragraphs	Change Summary
G	03/05/2013	S. Slobin	Table 10 Section 2.1.1.3 Table A-5 Figures 16-19 and 30-33;	Revised references to wind effects. Section 2.1.1.3 re-written to address gain and pointing effects due to wind. Values in Table A-5 changed slightly. Figures 16-19 and 30-33 changed slightly. Minor cosmetic changes throughout.
H	04/01/2015	Stephen Slobin Christine Chang	Rev.G Tables 3,9 Figures 5,7,21 Section 2 & Table 1 Table 1 Tables 1,4 Table 3 Tables 6 & 7 Table 7 Table 8 Table 9 Figure 2 Figure 3 Figures 9, 18, 24, 33 Tables A-2 & A-4 Table A-3 Sections 2, 3 Tables 1, 3	Deleted. DSS-27 HSB antenna decommissioned. Added DSS-35 capabilities. Clarified no simultaneous X-band RCP and LCP for DSS-34 and -54. Clarified simultaneous Ka-band RCP and LCP operation. Corrected S-band uplink power. Updated Ka-band uplink power. Added DSS-35 transmit values. Clarified location of X-band acquisition antennas. Added note about low-gain mode noise temperature increase at X- and Ka-bands. Added DSS-35 receive values. Corrected Ka-band polarizations. Revised X-band HEMT bandwidths. Updated wind effect gain reduction. Added DSS-35 Tamw and Top values. Removed note on transmit table. Added DSS-35 to caption. Added DSS-35 X- and Ka-band gain and noise temperatures. Added DSS-35 gain and noise temperature parameters. Added notes about low-gain mode noise temperature increase at X- and Ka-bands. Added note about low-gain mode noise temperature increase at K-band. Added details of 80 kW X-band transmitter at DSS-26.

Rev	Issue Date	Prepared By	Affected Paragraphs	Change Summary
I	02/10/2017	Stephen Slobin Christine Chang	<p>Sections 2, 3 Table 1</p> <p>Tables 1, 2, 3, 5, 7, 9</p> <p>Figure 3</p> <p>Figure 5 Figure 6</p> <p>Figures 7, 24</p> <p>Figures 12, 22</p> <p>Figures 29, 39</p> <p>Figures 1-44</p> <p>Tables A-1, A-2, A-4</p> <p>Table A-1</p>	<p>Implementation dates for future antennas DSS-33, -53, -56, and 80 kW X-band transmitter additions at future antennas DSS-33, -53.</p> <p>DSS-36 added.</p> <p>DSS-55 removed, new high-power X-band feed shown. New for DSS-36. New for DSS-55.</p> <p>Re-drawn for DSS-34, replacing DSS-24. New for DSS-36 X- and Ka-band gain. New for DSS-36 X- and Ka-band noise temperatures. Renumbered to accommodate four new DSS-36 figures and two additional block diagrams. DSS-36 added.</p> <p>S-band G_0 uplink gains for DSS-24, -34, -54 re-calculated.</p>

Table of Contents

Section 1 Introduction.....	11
1.1 Purpose	11
1.2 Scope.....	11
Section 2 General Information.....	12
2.1 Telecommunications Parameters	14
2.1.1 Antenna Gain Variation.....	14
2.1.1.1 Frequency Effects.....	14
2.1.1.2 Elevation Angle Effects.....	14
2.1.1.3 Wind Effects.....	15
2.1.2 System Noise Temperature Variation	15
2.1.3 Antenna Pointing.....	16
2.1.3.1 Pointing Accuracy	16
2.1.3.2 Pointing Loss.....	16
2.1.3.3 Monopulse-aided Pointing	17
2.1.3.4 Ka-Band Aberration Correction	17
2.1.3.5 X-Band Acquisition.....	17
Section 3 Proposed Capabilities.....	18
Appendix A Equations for Modeling.....	A-1
A.1 Equations for Gain Versus Elevation Angle.....	A-1
A.2 Equations for System Temperature Versus Elevation Angle.....	A-1
A.3 Equation for Gain Reduction Versus Pointing Error	A-3
A.4 Equation for Transmit Aberration Gain Reduction	A-3

List of Tables

Table 1.	Summary of Available Configurations for Each Antenna.....	19
Table 2.	S-Band Transmit Characteristics, DSS-24, -34, -36, and -54.....	24
Table 3.	X-Band Transmit Characteristics, DSS-24, -25, -26, -34, -35, -36, -54,.....	27
Table 4.	Ka-Band Transmit Characteristics, DSS-25	31
Table 5.	S- and K-Band Receive Characteristics, DSS-24, -34, -36, and -54	33
Table 6.	X-Band Receive Characteristics, DSS-24.....	36
Table 7.	X- and Ka-Band Receive Characteristics, DSS-25, -26, -34, -35, -36, -54, and -55	38
Table 8.	Gain Reduction Due to Wind Effects on Structural Deformation and Pointing Error.....	43
Table 9.	T_{AMW} , T_{sky} , and T_{op} for CD=25% Average Clear Weather at Zenith, Referenced to Feedhorn Aperture.....	44
Table A-1.	S-Band Vacuum Gain and Antenna-Microwave Noise Temperature Parameters, Referenced to Feedhorn Aperture	A-4
Table A-2.	X-Band Vacuum Gain and Antenna-Microwave Noise Temperature Parameters, Referenced to Feedhorn Aperture	A-5
Table A-3.	K-Band Vacuum Gain and Antenna-Microwave Noise Temperature Parameters, Referenced to Feedhorn Aperture	A-7
Table A-4.	Ka-Band Vacuum Gain and Antenna-Microwave Noise Temperature Parameters, Referenced to Feedhorn Aperture	A-10
Table A-5.	S-, X-, K-, and Ka-Band Zenith Atmospheric Attenuation (A_{zen}).....	A-12

List of Figures

Figure 1. Functional Block Diagram of the DSS-24 Antenna.....	47
Figure 2. Functional Block Diagram of the DSS-25 Antenna.....	48
Figure 3. Functional Block Diagram of the DSS-26 and DSS-35 Antennas.....	49
Figure 4. Functional Block Diagram of the DSS-34 and DSS-54 Antennas.....	50
Figure 5. Functional Block Diagram of the DSS-36 Antenna.....	51
Figure 6. Functional Block Diagram of the DSS-55 Antenna.....	52
Figure 7. DSS-34 (Canberra) S-Band Receive Gain versus Elevation Angle, S/X- Mode (S/X Dichroic In Place), 2295 MHz.....	53
Figure 8. DSS-25 (Goldstone) X-Band Receive Gain versus Elevation Angle, X/Ka- Mode (X/Ka Dichroic In Place), 8420 MHz.....	53
Figure 9. DSS-26 (Goldstone) X-Band Receive Gain versus Elevation Angle, X/Ka- Mode, 8420 MHz.....	54
Figure 10. DSS-34 (Canberra) X-Band Receive Gain versus Elevation Angle, X/Ka- Mode (S/X Dichroic Retracted), 8420 MHz.....	54
Figure 11. DSS-35 (Canberra) X-Band Receive Gain versus Elevation Angle, X/Ka- Mode, 8420 MHz.....	55
Figure 12. DSS-36 (Canberra) X-band Receive Gain versus Elevation Angle, X/Ka- Mode, 8420 MHz.....	55
Figure 13. DSS-54 (Madrid) X-Band Receive Gain versus Elevation Angle, X/Ka-Mode (S/X Dichroic Retracted), 8420 MHz.....	56
Figure 14. DSS-55 (Madrid) X-Band Receive Gain versus Elevation Angle, X/Ka Mode, 8420 MHz.....	56
Figure 15. DSS-24 (Goldstone) K-Band Receive Gain versus Elevation Angle, K-Only Mode (S/K Dichroic Retracted), 26000 MHz.....	57
Figure 16. DSS-34 (Canberra) K-Band Receive Gain versus Elevation Angle, K-Only Mode (S/K Dichroic Retracted), 26000 MHz.....	57
Figure 17. DSS-54 (Madrid) K-Band Receive Gain versus Elevation Angle, K-Only Mode (S/K Dichroic Retracted), 26000 MHz.....	58
Figure 18. DSS-25 (Goldstone) Ka-Band Receive Gain versus Elevation Angle, X/Ka- Mode (X/Ka Dichroic In-Place), 32000 MHz.....	58
Figure 19. DSS-26 (Goldstone) Ka-Band Receive Gain versus Elevation Angle, X/Ka- Mode, 32000 MHz.....	59
Figure 20. DSS-34 (Canberra) Ka-Band Receive Gain versus Elevation Angle, X/Ka- Mode, 32000 MHz.....	59
Figure 21. DSS-35 (Canberra) Ka-Band Receive Gain versus Elevation Angle, X/Ka- Mode, 32000 MHz.....	60
Figure 22. DSS-36 (Canberra) Ka-Band Receive Gain versus Elevation Angle, X/Ka- Mode, 32000 MHz.....	60

Figure 23. DSS-55 (Madrid) Ka-Band Receive Gain versus Elevation Angle,X/Ka-Mode, 32000 MHz.....	61
Figure 24. DSS-34 (Goldstone) S-Band System Temperature versus Elevation Angle, S/X-Mode (S/X Dichroic In Place), Non-Diplexed Path, 2295 MHz.....	61
Figure 25. DSS-25 (Goldstone) X-Band System Temperature versus Elevation Angle, X/Ka-mode (X/Ka Dichroic In Place), Non-Diplexed Path, MASER-1, 8420 MHz	62
Figure 26. DSS-26 (Goldstone) X-Band RCP System Temperature versus Elevation Angle, X/Ka-Mode, 8420 MHz	62
Figure 27. DSS-34 (Canberra) X-Band RCP System Temperature versus Elevation Angle, X/Ka-Mode (S/X Dichroic Retracted), 8420 MHz.....	63
Figure 28. DSS-35 (Canberra) X-Band RCP System Temperature versus Elevation Angle, X/Ka-Mode, 8420 MHz	63
Figure 29. DSS-36 (Canberra) X-Band RCP System Temperature versus Elevation Angle, X/Ka-Mode, 8420 MHz	64
Figure 30. DSS-54 (Madrid) X-Band RCP System Temperature versus Elevation Angle, X/Ka-Mode (S/X Dichroic Retracted), 8420 MHz.....	64
Figure 31. DSS-55 (Madrid) X-Band RCP System Temperature versus Elevation Angle, X/Ka-Mode, 8420 MHz.....	65
Figure 32. DSS-24 (Goldstone) K-Band RCP System Temperature versus Elevation Angle, K-only Mode (S/K Dichroic Retracted), 26000 MHz.....	65
Figure 33. DSS-34 (Canberra) K-Band RCP System Temperature versus Elevation Angle, K-only Mode (S/K Dichroic Retracted), 26000 MHz.....	66
Figure 34. DSS-54 (Madrid) K-Band RCP System Temperature versus Elevation Angle, K-only Mode (S/K Dichroic Retracted), 26000 MHz	66
Figure 35. DSS-25 (Goldstone) Ka-Band System Temperature versus Elevation Angle, X/Ka-Mode (X/Ka Dichroic in Place), 32000 MHz.....	67
Figure 36. DSS-26 (Goldstone) Ka-Band RCP System Temperature versus Elevation Angle, X/Ka-Mode, 32000 MHz	67
Figure 37. DSS-34 (Canberra) Ka-Band RCP System Temperature versus Elevation Angle, X/Ka-Mode, 32000 MHz	68
Figure 38. DSS-35 (Canberra) Ka-Band RCP System Temperature versus Elevation Angle, X/Ka-Mode, 32000 MHz	68
Figure 39. DSS-36 (Canberra) Ka-Band RCP System Temperature versus Elevation Angle, X/Ka-Mode, 32000 MHz	69
Figure 40. DSS-55 (Madrid) Ka-Band RCP System Temperature versus Elevation Angle, X/Ka-Mode, 32000 MHz	69
Figure 41. S-Band Gain Reduction versus Angle off Boresight.....	70
Figure 42. X-Band Gain Reduction versus Angle off Boresight.....	70

Figure 43. K- and Ka-Band Gain Reduction versus Angle off Boresight71
Figure 44. Ka-Band Transmit Gain Reduction Due to Aberration Correction.....71

Section 1

Introduction

1.1 Purpose

This module provides the performance parameters for the Deep Space Network (DSN) 34m Beam Waveguide (BWG) antennas that are necessary to perform the nominal design of a telecommunications link. It also summarizes the capabilities of these antennas for mission planning purposes and for comparison with other ground station antennas.

Because of the large number of BWG antennas, the four frequency bands, and the large number of operating modes and configurations, the reader will find it helpful to refer to Table A-1 through Table A-4, in addition to Table 1, to keep the capabilities and differences among the antennas clear. Reference to the antenna block diagrams (Figure 1 through Figure 6) will clearly show the microwave equipment configurations

1.2 Scope

The scope of this module is limited to providing those parameters that characterize the RF performance of the 34-meter BWG antennas, including the effects of weather for a limited number of weather conditions. A more complete discussion of weather effects is given in module 105, Atmospheric and Environmental Effects. This module does not discuss mechanical restrictions on antenna performance covered in module 302, Antenna Positioning.

Section 2 General Information

The 34-meter diameter BWG (beam waveguide) antennas are the latest generation of antennas built for use in the DSN. These antennas differ from more conventional antennas (for example, the 34-meter HEF antennas, described in module 103) in the fact that a series of mirrors, approximately 2.4 meters in diameter, direct microwave energy from the region above the main reflector to a location in a pedestal room at the base of the antenna. The pedestal room is located below the azimuth track of the antenna and is below ground level.

In this configuration, several “positions” of microwave equipment contained in the pedestal room can be accessed by rotation of an ellipsoidal mirror located in the center of the pedestal room floor beneath the azimuth axis of the antenna. This enables great versatility of design and allows tracking with equipment at one position while equipment installation or maintenance is carried out at the other positions. Since cryogenic low-noise amplifiers (LNAs) do not tip as they do when located above the elevation axis, certain state-of-the-art, ultra-low noise amplifier (ULNA) and feed designs can be implemented.

The capabilities of each antenna differ depending on the microwave, transmitting, and receiving equipment installed. A summary of these differences is provided in Table 1. Functional block diagrams for each antenna are provided in Figure 1 through Figure 6. In general, each antenna has at least one LNA for each supported frequency band. However, stations that can support simultaneous right circular polarization (RCP) and left circular polarization (LCP) in the same band have an LNA for each. In addition, the stations that support Ka-band contain an additional LNA to enable monopulse tracking when using RCP polarization. Each antenna also has at least one transmitter. Antennas with more than one transmitter can operate only one of them at a time. DSS-25 is an exception and has a Ka-band transmitter that can be operated at the same time as its X-band transmitter.

There are four stations, DSS-24, -34, -36, and -54, that are capable of receiving selectable (one polarization at a time) RCP or LCP at S-band. DSS-24, -34, and -54 are also capable of simultaneously (with S-band) or independently receiving selectable (one polarization at a time) RCP or LCP at X-band due to the fact that there is only a single LNA at DSS-24, and a single X-band downconverter at DSS-24, -34, and -54. The remaining BWG stations, DSS-25, -26, -35, -36, and -55, can receive both X-band polarizations simultaneously. K-band (26 GHz) receive capability with selectable (one polarization at a time) RCP or LCP exists at DSS-24, DSS-34, and DSS-54. Ka-band capability, including monopulse-assisted tracking of RCP signals, exists at DSS-25, -26, -34, -35, -36, -54, and -55. DSS-26, -34, -35, -36, -54, and -55 can also receive Ka-band RCP and LCP simultaneously for radio science investigations, without monopulse assisted tracking. DSS-25 cannot receive Ka-band LCP.

The 26 GHz receive capability can be used independently or in combination with the station’s S-band capability to provide a high-rate return link capability for spacecraft operating at less than 2×10^6 km (near-Earth) ranges. A low gain mode is included to accommodate high signal levels that are expected during the early post-launch phase of 26 GHz missions. Neither the X-band receive capability at DSS-24, nor the X-band or Ka-band receive capabilities at DSS-34 and -54 are available when K-band receive is being used at these stations. The retractable mirror over the X-band or X/Ka-band feeds must be retracted for K-band reception. S-band performance in the

S/X and S/K modes is identical. The S-band transmitter at DSS-36 is 250 W, and the S-band transmitters at DSS-24, -34, -54 are 20 kW. These S-band transmitters, and the X-band transmitters at DSS-24 and -25, are coupled into the microwave path using a frequency-selective diplexer. Because the diplexer increases the operating system noise temperature, a non-diplexed path for receive-only operation is provided at all of these antennas. The X-band diplexing function at DSS-26, -34, -35, -36, -54, and -55 is accomplished using the frequency-selective characteristics of the feed in conjunction with an external polarizing network. This technique does not affect the operating system temperature, so they are considered to be always diplexed and no lower-noise non-diplexed configuration is necessary or available. All BWG antennas have a 20 kW X-band transmitter; and additionally, DSS-26 has an 80 kW transmitter which became available in June 2015. See Section 3 for the schedule of 80 kW transmitter additions to future antennas DSS-33 (Canberra) and DSS-53 (Madrid).

When an S-band uplink is required, the received S-band polarization must be the same as is being transmitted. X-band uplinks can be of either polarization independent of the polarization or polarizations of any signals being received. X-band uplinks are not available in conjunction with S-band downlinks due to bandwidth restrictions of the S/X dichroic plate. This dichroic plate must be retracted for X-band uplink operation, and thus S-band downlink is no longer available.

DSS-24, -34, -36, and -54 have a retractable S/X dichroic plate to enable operation in an S/X downlink mode, or X-only if the dichroic plate is retracted. Additionally, DSS-24, -34, -54 also have a retractable S/K (S/26 GHz) dichroic plate for operation in an S/K mode or K-only if the dichroic plate is retracted. When operating in the S/X mode, and the S/X dichroic is being retracted to enable X-uplink operation, there will be about a one minute interruption of X-downlink due to the blockage and/or mis-positioning of the dichroic plate.

The S-band transmitters at DSS-24, -34, -36, and -54, when operated near their maximum power rating, produce sufficient 13th harmonic power to adversely affect telemetry reception in the 26 GHz band. Mission designers selecting an uplink frequency between 2025 and 2076.9 MHz and requiring a radiated power in excess of 5.0 kW should select a downlink frequency such that the 13th harmonic of the uplink frequency does not fall within the bandwidth required for their telemetry.

When simultaneous X-band uplink and downlink of the same polarization are required at stations with waveguide diplexers (DSS-24 and DSS-25), reception must be through the diplexer, and the noise will be increased over that of the non-diplexed path. DSS-25 has two X-band LNAs and can receive simultaneous RCP and LCP, although one of the signals will be via the non-diplexed path and the other will be via the diplexed path. DSS-26, -34, -35, -36, -54, and -55 also have two X-band LNAs, one for each polarization. As these stations do not have waveguide diplexers, the system noise temperature in each polarization is approximately the same. Although there are two X-band LNAs at DSS-34 and DSS-54, there is only a single-channel X-band downconverter, so simultaneous RCP and LCP reception is not possible.

Additionally, all BWG antennas offer a low-gain mode (-20 dB) for use at high received signal power levels for spacecraft near the Earth. The X- and Ka-band low-gain equipment is not shown in the antenna block diagrams in this module (only K-band is, for DSS-24, -34, and -54). Reference to the HEF antenna block diagrams of 810-005 module 103 will show the X-band low-gain equipment for those antennas.

2.1 Telecommunications Parameters

The significant parameters of the 34-meter BWG antennas that influence the design of the telecommunications link are listed in Table 2 through Table 9. Variations of these parameters that are inherent in the design of the antennas are discussed below. Other factors that degrade link performance are discussed in modules 105 (Atmospheric and Environmental Effects) and 106 (Solar Corona and Solar Wind Effects).

The values in these tables do not include the effects of the atmosphere. However, the attenuation and noise-temperature effects of weather for three specific weather conditions are included in the figures at the end of the module so that they may be used for a quick estimate of telecommunications link performance for those specific conditions, without reference to module 105. For detailed design control table use, the more comprehensive and detailed S-, X-, K-, and Ka-band weather effects models (for weather conditions up to 99% cumulative distribution) in module 105 should be used.

2.1.1 Antenna Gain Variation

Because the gain is referenced to the feedhorn aperture, such items as duplexers and waveguide runs to alternate LNAs that are “downstream” (below the feedhorn aperture, toward the LNA), do not affect the gain at the reference plane. Dichroic plates that are “upstream” of the feedhorn aperture cause a reduction in gain.

2.1.1.1 Frequency Effects

Antenna gains are specified at the indicated frequency (f_0). For operation at higher or lower frequencies in the same band, the gain (dBi) must be increased or reduced, respectively, by $20 \log (f/f_0)$.

2.1.1.2 Elevation Angle Effects

Structural deformation causes a reduction in gain when the antenna is operated at an elevation angle other than where the reflector panels were aligned. The effective gain of the antenna also is reduced by atmospheric attenuation, which is a function of elevation. Figure 7 through Figure 23 show representative curves of gain versus elevation angle for selected stations and configurations. The gain curves show the hypothetical vacuum (no atmosphere) condition, and the gain with 0%, 50%, and 90% weather conditions, designated as CD (cumulative distribution) = 0.00, 0.50, and 0.90. 0% means minimum weather effect (exceeded 100% of the time); 90% means that effect which is exceeded only 10% of the time. Qualitatively, 0% corresponds to the driest, lowest-loss condition of the atmosphere; 25% corresponds to average clear; 50% corresponds to humid or very light clouds; and 90% corresponds to very cloudy, but with no rain. Appendix A provides the complete set of parameters from which these curves were created. These parameters, in combination with the weather effects parameters from module 105, can be used to calculate the gain versus elevation angle curve for any antenna, in any configuration, for weather conditions up to 99% CD.

2.1.1.3 Wind Effects

A study of tracking data from the Kepler spacecraft at Ka-band during windy conditions shows minimal effects on gain degradation (due to structural deformation of the antenna) and pointing loss (due to gusty winds of varying direction). A realistic upper limit of these effects at Ka-band can be considered to be 0.8 dB for wind speeds up to 50 km/hr. The effects at S-, X-, and K-bands, all lower frequencies, are expected to be even less than at Ka-band. Cumulative probability distributions of wind velocity at Goldstone are given in module 105. At Goldstone, the windiest of the DSN antenna locations, 50 km/hr wind is exceeded about 2% of the year and 5% of the worst month (April). An estimate of these effects at S-, X-, K-, and Ka-bands at wind speeds of 10, 30, and 50 km/hr is shown in Table 8.

2.1.2 System Noise Temperature Variation

The operating system temperature (T_{op}) varies as a function of elevation angle due to changes in the path length through the atmosphere and ground noise received by the sidelobe pattern of the antenna. Figure 24 through Figure 40 show the combined effects of these factors for the same set of stations and configurations selected above. The figures show the antenna and microwave contribution alone, and also the system operating noise temperature (T_{op}) with 0%, 50%, and 90% weather conditions. The equations and parameters for these curves are provided in Appendix A.2 and can be used, in combination with the weather effects parameters from module 105, to calculate the system temperature versus elevation curve for any antenna, in any configuration, for weather conditions up to 99% CD. The values of zenith atmospheric attenuation (A_{zen}) used in generating these figures are given in Table A-5.

The system operating noise temperature, T_{op} , consists of two parts, an *antenna-microwave component*, T_{AMW} , for the contribution of the antenna and microwave hardware only, and a *sky component*, T_{sky} , that consists of the atmosphere noise, plus the cosmic microwave background (CMB) noise attenuated by the atmosphere loss. T_{AMW} is shown in Figure 20 through Figure 34 as “ANT-UWV”. The system operating noise temperature is given by

$$T_{op}(\theta) = T_{AMW} + T_{sky} = \left[T_1 + T_2 e^{-a\theta} \right] + \left[T_{atm}(\theta) + T'_{CMB}(\theta) \right]$$

where

T_1 , T_2 and a are coefficients and exponent given in Appendix A, Table A-1 through Table A-4

T_{atm} is the atmosphere contribution term, calculated from Module 105

T'_{CMB} is the attenuated cosmic contribution, calculated from Module 105

More details of this calculation are given in Appendix A of this module.

The T_{AMW} noise temperature values in Table 5 through Table 9 are stated with reference to the feedhorn aperture and arise from antenna and microwave hardware contribution only. No atmosphere or cosmic background contribution is included. Table 9 presents values of T_{AMW} , T_{sky} , and T_{op} for all antenna frequencies and configurations at zenith, with average-clear CD = 0.25 weather. The values of T_{sky} in Table 9 are calculated by methods presented in Module 105,

using year-average attenuation values of that module. The values of A_{zen} used in calculating T_{sky} for CD = 25% average clear weather are given in Table A-5.

At DSS-36, the addition of quadripod leg shields to reduce transmitted power in the near field has resulted in a T_{AMW} with a small “bump” of about 4-5 K at X-band and 1 K at Ka-band in the elevation range of 6-12 degrees. Normal exponential curve fitting to the data attempts to minimize the T_{op} error when creating a system noise temperature model for 90% CD weather, a model which is typically used in telecom link design. The range of T_{op} errors of this model in the 6-12 degree elevation range is 0.1 dB low (optimistic) to 0.2 dB high (pessimistic). It is felt that these low errors are acceptable for typical telecom link design.

System noise temperature increases in the low-gain mode can be approximated for telecom modeling purposes as +20 K at X-band, +180 K at K-band, and +70 K at Ka-band.

2.1.3 Antenna Pointing

2.1.3.1 Pointing Accuracy

The pointing accuracy of an antenna, often referred to as its *blind-pointing* performance, is the difference between the calculated (or commanded) beam direction and the actual beam direction. The error is typically random (after the systematic contributions have been removed by a “blind pointing model”) and can be divided into two major categories. The first of these includes the computational errors and uncertainties associated with the radio sources used to calibrate the antenna, and the location of the spacecraft provided by its navigation team. The second has many components associated with converting a calculated beam direction to the physical positioning of a large mechanical structure. Included are such things as atmospheric wind and refraction effects, servo and encoder errors, thermally and gravitationally induced structural deformation, azimuth track leveling (for an azimuth-elevation antenna), and both seismic and diurnal ground tilt.

Blind pointing is modeled by assuming equal pointing performance in the elevation (EL) and cross-elevation (X-EL) directions. That is, the random pointing errors in each direction have uncorrelated Gaussian distributions with the same standard deviation. This results in a Rayleigh distribution for pointing error where the mean radial error is 1.2533 times the standard deviation of the EL and X-EL components. For a Rayleigh distribution, the probability that the pointing error will be less than or equal to the mean radial error is 54.4%. Conversely, the probability that the mean radial error will be exceeded is 45.6%.

810-005 module 302 (Antenna Positioning) presents blind pointing performance (mean radial error) for the DSN antennas.

2.1.3.2 Pointing Loss

Figure 41 through Figure 43 show the effects of pointing error on effective transmit and receive gain of the antenna. These curves are Gaussian approximations based on measured and predicted antenna beamwidths. The equations used to derive the curves are provided in Appendix A.3.

2.1.3.3 Monopulse-aided Pointing

Ka-band monopulse-aided pointing uses a monopulse tracking coupler within the cryogenic feed package to establish a feed pattern with a theoretical null on axis. The magnitude of the pointing error is proportional to the magnitude of the signal received by this pattern and the azimuthal error is proportional to the phase difference between the sum and difference outputs of the coupler. Thus, by measuring the complex ratio of the sum and difference signals, pointing corrections can be generated to instruct the antenna servo system to drive the pointing error to zero. The system achieves its specified performance when the ratio of the signal in the sum channel (that is, the signal from which tracking and telemetry information will be derived) to the noise level in the difference channel is 26 dB-Hz.

2.1.3.4 Ka-Band Aberration Correction

The extremely narrow beamwidth at Ka band requires that a Ka-band uplink signal be aimed at where the spacecraft will be when the signal arrives, while simultaneously receiving a signal that left the spacecraft one one-way light-time previously. This is accomplished by mounting the Ka-band transmit feed at DSS-25 on a movable X-Y platform that can displace the transmitted beam as much as 30 millidegrees from the received beam.

DSS-25 is the only antenna with a Ka-band transmit capability. The fact that the transmit feed is displaced from its optimum focus causes the gain reduction depicted in Figure 44. The equation used to generate this curve is provided in Appendix A.4.

2.1.3.5 X-Band Acquisition

A 1.2-m X-band acquisition antenna and receiver has been installed at the apex (above the subreflector) of the DSS-24, DSS-34, and DSS-54 antennas. The acquisition receiver employs the monopulse technique to develop pointing commands for the antenna during the launch phase when launch time and trajectory uncertainties make predict-driven pointing impractical. During acquisition, the acquisition system is responsible for antenna pointing, however forward and return link services are provided by the main antenna beam. The characteristics of the acquisition antennas are given in Table 6 (for DSS-24) and in Table 7 (for DSS-34 and DSS-54).

Section 3

Proposed Capabilities

The DSN is in the process of increasing the number of 34m BWG antennas. Future BWG antennas will be:

DSS-33 (Canberra), late-2022

DSS-53 (Madrid), late-2020

DSS-56 (Madrid), late-2019

DSS-33 and DSS-53 will be implemented with both 20 kW and 80 kW X-band transmitters on the dates shown above.

Table 1. Summary of Available Configurations for Each Antenna

Configuration	Uplink*	Downlink		Remarks
		Band	Polarization	
DSS-24 (BWG)				
S-Up, S-Down	S, 17.4 kW	S	RCP or LCP	<ul style="list-style-type: none"> Transmit and receive polarizations must be the same
S-Up, S/X-Down	S, 17.4 kW	S	RCP or LCP	<ul style="list-style-type: none"> S-band transmit and receive polarizations must be the same. X-band may use low noise (non-diplexed) or diplexed path.
		X	RCP or LCP	
S-Up, S/K-Down	S, 17.4 kW	S	RCP or LCP	<ul style="list-style-type: none"> S-band transmit and receive polarizations must be the same. Both K-band polarizations have similar noise characteristics.
		K	RCP or LCP	
S-Down Low Noise, with X-down, or with K-down, but not both	None	S	RCP or LCP	<ul style="list-style-type: none"> Non-diplexed path
		X	RCP or LCP	<ul style="list-style-type: none"> X-band may use low noise (non-diplexed) or diplexed path.
		K	RCP or LCP	<ul style="list-style-type: none"> Both K-band polarizations have similar noise characteristics
X-Up, X-Down	X, 18.2 kW	X	RCP or LCP	<ul style="list-style-type: none"> Transmit and receive polarizations are independent. Requires S/X dichroic plate to be retracted – no S-band.
X-Down Low Noise	None	X	RCP or LCP	<ul style="list-style-type: none"> Non-diplexed path with S/X dichroic plate retracted
K-Down, Low Noise	None	K	RCP or LCP	<ul style="list-style-type: none"> Requires S/K dichroic plate to be retracted – no S-band. Both K-band polarizations have similar noise characteristics

Table 1. Summary of Available Configurations for Each Antenna (continued)

Configuration	Uplink*	Downlink		Remarks
		Band	Polarization	
DSS-34 and DSS-54 (BWG)				
S-Up, S-Down	S, 17.4 kW	S	RCP or LCP	<ul style="list-style-type: none"> Transmit and receive polarizations must be the same.
S-Up, S/X-Down	S, 17.4 kW	S	RCP or LCP	<ul style="list-style-type: none"> S-band transmit and receive polarizations must be the same. Both X-band polarizations have similar noise characteristics.
		X	RCP or LCP	
S-Up, S/K-Down	S, 17.4 kW	S	RCP or LCP	<ul style="list-style-type: none"> S-band transmit and receive polarizations must be the same. Both K-band polarizations have similar noise characteristics.
		K	RCP or LCP	
S-Down Low Noise with X-Down, or with K-Down, but not both	None	S	RCP or LCP	<ul style="list-style-type: none"> Non-diplexed path
		X	RCP or LCP	<ul style="list-style-type: none"> Both X-band polarizations have similar noise characteristics.
		K	RCP or LCP	<ul style="list-style-type: none"> Both K-band polarizations have similar noise characteristics.
X-Up, X-Down	X, 17.4 kW	X	RCP or LCP	<ul style="list-style-type: none"> Transmit and receive polarizations are independent. Feed diplexer does not affect noise characteristics.
K-Down, Low Noise	None	K	RCP or LCP	<ul style="list-style-type: none"> Requires S/K dichroic plate to be retracted – no S-band. Both K-band polarizations have similar noise characteristics.
X-Up, X/Ka-Down, Ka-Monopulse	X, 17.4 kW	X	RCP or LCP	<ul style="list-style-type: none"> X-band transmit and receive polarizations are independent. Monopulse is optionally available for Ka-band RCP and prevents use of LCP.
		Ka	RCP only	
X-Up, X/Ka-Down, Dual Polarization	X, 17.4 kW	X	RCP or LCP	<ul style="list-style-type: none"> X-band transmit and receive polarizations are independent. Simultaneous Ka RCP and LCP prevents use of monopulse.
		Ka	RCP and LCP	
NOTE: Simultaneous X-band RCP and LCP not available at DSS-34 and DSS-54 due to having only a single-channel X-band downconverter, thus RCP “or” LCP.				

Table 1. Summary of Available Configurations for Each Antenna (continued)

Configuration	Uplink*	Downlink		Remarks
		Band	Polarization	
DSS-25 (BWG)				
X-Up, X-Down	X, 18.2 kW	X	RCP and LCP	<ul style="list-style-type: none"> • Polarization that matches transmit uses higher noise diplexed path. • Opposite (to transmit) polarization uses low noise (non-diplexed) path.
X-Down Low Noise	None	X	RCP and LCP	<ul style="list-style-type: none"> • One polarization is low noise (via non-diplexed path). • Opposite polarization is available via higher noise diplexed path.
X/Ka-Down, Ka-Monopulse	None	X	RCP and LCP	<ul style="list-style-type: none"> • One X-band polarization is low noise (via non-diplexed path). • Opposite polarization is available via higher noise diplexed path. * Use of monopulse is optional.
		Ka	RCP only	
X-Up, X/Ka-Down, Ka-Monopulse	X, 18.2 kW	X	RCP and LCP	<ul style="list-style-type: none"> • Polarization that matches transmit uses higher noise diplexed path. • Opposite (to transmit) polarization uses low noise (non-diplexed) path. * Use of monopulse is optional.
		Ka	RCP only	
X/Ka-Up, X/Ka-Down, Ka-Monopulse	X, 18.2 kW	X	RCP and LCP	<ul style="list-style-type: none"> • X-band polarization that matches transmit uses higher noise diplexed path. • Opposite (to X-band transmit) polarization uses low noise (non-diplexed) path. • Use of monopulse is optional. • Ka-Up is reconfigurable to RCP with equipment change.
	Ka, 283 W, LCP-only	Ka	RCP only	
Ka-Up, Ka-Down, Ka-Monopulse	Ka, 283 W, LCP-only	Ka	RCP only	<ul style="list-style-type: none"> • Lowest noise configuration (X/Ka dichroic plate retracted) • Use of monopulse is optional. • Ka-Up is reconfigurable to RCP with equipment change.

Table 1. Summary of Available Configurations for Each Antenna (continued)

Configuration	Uplink*	Downlink		Remarks
		Band	Polarization	
DSS-26, DSS-35, and DSS-55 (BWG)				
X-Up, X-Down	X, 17.4 kW X, 67.6 kW (see NOTE)	X	RCP and LCP	<ul style="list-style-type: none"> • Transmit and receive polarizations are independent. • Both X-band receive polarizations are available with similar noise characteristics.
X-Up, X/Ka-Down, Ka-Monopulse	X, 17.4 kW X, 67.6 kW (see NOTE)	X	RCP and LCP	<ul style="list-style-type: none"> • Transmit and receive polarizations are independent. • Feed diplexer does not affect noise characteristics. • Both X-band receive polarizations are available with similar noise characteristics. • Monopulse is optional for Ka-band RCP.
		Ka	RCP only	
X-Up, X/Ka-Down, Dual Polarization	X, 17.4 kW X, 67.6 kW (see NOTE)	X	RCP and LCP	<ul style="list-style-type: none"> • X-band transmit and receive polarizations are independent. • Both X-band receive polarizations are available with similar noise characteristics. • Both Ka-band receive polarizations are available with similar noise characteristics. • Simultaneous RCP and LCP prevents use of monopulse.
		Ka	RCP and LCP	
X/Ka-Down, Ka-Monopulse	None	X	RCP and LCP	<ul style="list-style-type: none"> • Both X-band receive polarizations are available with similar noise characteristics. • Monopulse is optional for Ka-band RCP.
		Ka	RCP only	
X/Ka-Down, Dual Polarization	None	X	RCP and LCP	<ul style="list-style-type: none"> • Both X-band receive polarizations are available with similar noise characteristics. • Both Ka-band receive polarizations are available with similar noise characteristics. • Simultaneous RCP and LCP prevents use of monopulse.
		Ka	RCP and LCP	

Table 1. Summary of Available Configurations for Each Antenna (continued)

Configuration	Uplink*	Downlink		Remarks
		Band	Polarization	
DSS-36 (BWG)				
S-Up, S-Down	S, 200 W	S	RCP or LCP	<ul style="list-style-type: none"> Transmit and receive polarizations must be the same.
S-Up, S/X-Down	S, 200 W	S	RCP or LCP	<ul style="list-style-type: none"> S-band transmit and receive polarizations must be the same. Both X-band polarizations have similar noise characteristics.
		X	RCP and LCP	
S-Down Low Noise, X-Down	None	S	RCP or LCP	<ul style="list-style-type: none"> Non-diplexed path Both X-band polarizations have similar noise characteristics.
		X	RCP and LCP	
X-Up, X-Down	X, 17.4 kW	X	RCP and LCP	<ul style="list-style-type: none"> Transmit and receive polarizations are independent. Feed diplexer does not affect noise characteristics.
X-Up, X/Ka-Down, Ka-Monopulse	X, 17.4 kW	X	RCP and LCP	<ul style="list-style-type: none"> X-band transmit and receive polarizations are independent. Monopulse is optionally available for Ka-band RCP and prevents use of LCP.
		Ka	RCP only	
X-Up, X/Ka-Down, Dual Polarization	X, 17.4 kW	X	RCP and LCP	<ul style="list-style-type: none"> X-band transmit and receive polarizations are independent. Simultaneous Ka RCP and LCP prevents use of monopulse.
		Ka	RCP and LCP	
NOTE: Simultaneous X-band RCP and LCP is available at DSS-36 because there is a dual-channel X-band downconverter, thus RCP “and” LCP.				

* The power listed in this column refers to the maximum available uplink power at the feedhorn aperture, accounting for waveguide loss between transmitter output and feedhorn aperture

NOTE: X-band 67.6 kW is available at DSS-26 as of 6/2015 and will be available at future antennas DSS-33 (Canberra) in late 2022, and DSS-53 (Madrid) in late 2020.

Table 2. S-Band Transmit Characteristics, DSS-24, -34, -36, and -54

Parameter	Value	Remarks
ANTENNA		
Gain at 2072.5 MHz (center of Near-Earth Band, 2025-2110 MHz)	56.0 +0.2,-0.3 dBi (DSS-24, -34, -54) 55.8 +0.2,-0.3 dBi (DSS-36)	At peak of gain versus elevation curve, referenced to feedhorn aperture for matched polarization; no atmosphere included; triangular probability density function (PDF) tolerance.
Gain at 2115 MHz (center of Deep-Space Band, 2110-2120 MHz)	56.2 +0.2,-0.3 dBi (DSS-24, -34, -54 only)	At peak of gain versus elevation curve, referenced to feedhorn aperture for matched polarization; no atmosphere included; triangular probability density function (PDF) tolerance
Transmitter Waveguide Loss	0.6 ±0.1 dB 1.0 ±0.1 dB	20-kW transmitter output terminal (waterload switch) to feedhorn aperture (DSS-24,-34,-54) DSS-36 250-W transmitter
Half-Power Beamwidth	0.263 ±0.020 deg	Angular width (2-sided) between half-power points at specified frequency
Polarization	RCP or LCP	One polarization at a time, remotely selected. Polarization must be the same as received polarization.
Ellipticity	1.0 dB (max)	Peak-to-peak axial ratio defined as the ratio of peak-to-trough received voltages with a rotating linearly polarized source and the feed configured as a circularly (elliptically) polarized receiving antenna.
Pointing Loss		
Angular	See module 302	See also Figure 41.
CONSCAN	0.01 dB	S-band loss using X-band CONSCAN
	0.1 dB	S-band loss using S-band CONSCAN

Parameter	Value	Remarks
EXCITER AND TRANSMITTER		
Frequency Range Covered	2025–2120 MHz	Power amplifier is step-tunable over the specified range in six 20-MHz segments, with 5-MHz overlap between segments. Tuning between segments can be accomplished in 30 seconds.
Instantaneous 1-dB Bandwidth	20 MHz	
Coherent with earth orbiter S-band D/L allocation	2028.8–2108.7 MHz	240/221 turnaround ratio
Coherent with deep space S-band D/L channels	2110.2–2117.7 MHz	240/221 turnaround ratio
Coherent with deep space X-band D/L channels	2110.2–2119.8 MHz	880/221 turnaround ratio
RF Power Output		Referenced to transmitter output terminal (waterload switch). Settability is limited to 0.25 dB by measurement equipment precision.
2025–2110 MHz (Near-Earth Band)	53.0–73.0 +0.0,-1.0 dBm	DSS-24, -34, -54 (200 W – 20 kW) (Near-Earth and Deep-Space Bands)
2110-2120 MHz (Deep-Space Band)	54.0 +0.0,-1.0 dBm	DSS-36 (250 W) (Near-Earth Band Only)
<p>Power output varies across the bandwidth and may be as much as 1 dB below nominal rating. Performance will also vary from tube to tube. Normal procedure is to run the tubes saturated, but unsaturated operation is also possible. The point at which saturation is achieved depends on drive power and beam voltage. The 20-kW tubes are normally saturated for power levels greater than 60 dBm (1 kW). Minimum power out of the 20-kW tubes is about 53 dBm (200 W). Efficiency of the tubes drops off rapidly below nominal rated output.</p>		
EIRP (maximum, Near-Earth Band)	128.4 +0.2,-1.0 dBm (DSS-24, -34, -54) 108.8 +0.2,-1.0 dBm (DSS-36)	At gain set elevation angle, referenced to feedhorn aperture

Table 2. S-Band Transmit Characteristics, DSS-24, -34, -36, and -54 (continued)

Parameter	Value	Remarks
EIRP (maximum, Deep-Space Band)	128.6 +0.2, -1.0 dBm (DSS-24, -34, -54 only)	At gain set elevation angle, referenced to feedhorn aperture
Tunability		At transmitter output frequency
Phase Continuous Tuning Range	2.0 MHz	
Maximum Tuning Rate	±12.1 kHz/s	
Frequency Error	0.012 Hz	Average over 100 ms with respect to frequency specified by predicts
Ramp Rate Error	0.001 Hz/s	Average over 4.5 s with respect to rate calculated from frequency predicts
Stability		At transmitter output frequency
Output Power Stability		From initial calibration value over 8 hours at a fixed frequency
Saturated Drive	±0.3 dB peak	
Unsaturated Drive	±0.5 dB peak	
Output Power Variation		Across any 600 kHz segment
Saturated Drive	≤0.3 dB p-p	
Unsaturated Drive	≤0.5 dB p-p	
Group Delay Stability	≤ 3.5 ns rms	Ranging modulation signal path (see module 203) over 8 h period
Spurious Output	1–10 Hz -50 dB 10 Hz–1.5 MHz -60 dB 1.5 MHz–8 MHz -45 dB	Below carrier
2nd Harmonic	-85 dB	
3rd Harmonic	-85 dB	
4th Harmonic	-140 dB	At input to X-band horn, with transmitter set for 20-kW output
13th Harmonic		The 13th harmonic of the transmitter lies within the 25.5 – 27.0 GHz allocation for transmitter frequencies from 2025 to 2076.9 MHz and is presently unfiltered

Table 3. X-Band Transmit Characteristics, DSS-24, -25, -26, -34, -35, -36, -54, and -55

Parameter	Value	Remarks
ANTENNA		
Gain at 7167.5 MHz (center of 7145-7190 MHz)	67.09 +0.2,-0.3 dBi	At peak of gain versus elevation angle curve, referenced to feedhorn aperture for matched polarization; no atmosphere included; triangular PDF tolerance.
Transmitter Waveguide Loss		20 kW or 80 kW transmitter output terminal (waterload switch) to feedhorn aperture
DSS-24, -25	0.4 ±0.1 dB	20 kW transmitter
DSS-26, -34, -35, -36, -54, -55	0.6 ±0.1 dB 0.7 ±0.1 dB	20 kW transmitter 80 kW transmitter (DSS-26)
Half-Power Beamwidth	0.077 ±0.004 deg	Angular width (2-sided) between half-power points at specified frequency
Polarization	RCP or LCP	One polarization at a time, remotely selected, independent of received polarization.
Ellipticity	1.0 dB (max)	Peak-to-peak axial ratio. See Table 2 for definition.
Pointing Loss		
Angular	See module 302	See also Figure 42.
CONSCAN	0.1 dB	X-band loss with X-band CONSCAN reference set for 0.1 dB loss

Table 3. X-Band Transmit Characteristics, DSS-24, -25, -26, -34, -35, -36, -54, and -55 (continued)

Parameter	Value	Remarks
EXCITER AND TRANSMITTER		
Frequency range covered	7145–7235 MHz	S-band downlink is not available with X-band uplink because S/X Dichroic Plate will not pass X-band uplink frequencies.
Coherent with deep space X-band D/L channels	7149.6–7188.9 MHz	880/749 turnaround ratio
Coherent with deep space Ka-band D/L allocation	7149.6–7234.6 MHz	3344/749 turnaround ratio. Note: X-band uplink frequencies greater than 7190 MHz are outside deep space X-band uplink allocation.
RF Power Output		Referenced to 20/80-kW transmitter output terminal (waterload switch). Settability is limited to 0.25 dB by measurement equipment precision.
7145.0–7190.0 MHz	53.0–73.0 ±0.5 dBm	Deep space uplink allocation, 20 kW xmtr.
7145.0–7190.0 MHz	53.0–79.0 ±0.5 dBm	Deep space uplink allocation, 80 kW xmtr, DSS-26 only.
7190.0–7235.0 MHz	53.0–67.6 ±0.5 dBm	Earth orbiter uplink allocation, 20 kW xmtr, with 5700 W upper limit (DSS-24, -25, -34, -54, -55).
7190.0–7235.0 MHz	53.0–73.0 ±0.5 dBm	Earth orbiter uplink allocation, 20 kW xmtr, with 20 kW upper limit (DSS-26, -35, -36).
7190.0–7235.0 MHz	53.0–79.0 ±0.5 dBm	Earth orbiter uplink allocation, 80 kW xmtr, DSS-26 only.
Power output varies across the bandwidth and may be as much as 1 dB below nominal rating. Performance will also vary from tube to tube. Normal procedure is to run the tubes saturated, but unsaturated operation is also possible. The point at which saturation is achieved depends on drive power and beam voltage. Minimum power out of the 20-kW and 80-kW tubes is about 53 dBm (200 W). Efficiency of the tubes drops off rapidly below nominal rated output.		
EIRP (maximum)		At gain set elevation angle, referenced to feedhorn aperture
DSS-24, -25		
7145.0–7190.0 MHz	139.6 ±0.7 dBm	Deep space allocation, 20 kW transmitter.

Table 3. X-Band Transmit Characteristics, DSS-24, -25, -26, -34, -35, -36, -54, and -55 (continued)

Parameter	Value	Remarks
7190.0–7235.0 MHz	134.1 ±0.7 dBm	Earth orbiter allocation, 20 kW transmitter with 5700 W upper limit.
DSS-26,-34,-35,-36,-54,-55		
7145.0–7190.0 MHz	139.4 ±0.7 dBm	Deep space allocation, 20 kW transmitter.
7145.0–7190.0 MHz	145.2 ±0.7 dBm	Deep space allocation, 80 kW transmitter (DSS-26 only).
7190.0–7235.0 MHz	133.9 ±0.7 dBm	Earth orbiter allocation, 20 kW transmitter with 5700 W upper limit (DSS-34, -54, -55).
7190.0–7235.0 MHz	139.4 ±0.7 dBm	Earth orbiter allocation, 20 kW transmitter with 20 kW upper limit (DSS-26, -35, -36)
7190.0–7235.0 MHz	145.2 ±0.7 dBm	Earth orbiter allocation, 80 kW transmitter (DSS-26 only).
Tunability		At transmitter output frequency
Phase Continuous Tuning Range	2.0 MHz	
Maximum Tuning Rate	±12.1 kHz/s	
Frequency Error	0.012 Hz	Average over 100 ms with respect to frequency specified by predicts
Ramp Rate Error	0.001 Hz/s	Average over 4.5 s with respect to rate calculated from frequency predicts
Stability		At transmitter output frequency
Output Power Stability		From initial calibration value over 8 hours at a fixed frequency
Saturated Drive	±0.3 dB peak	
Unsaturated Drive	±0.5 dB peak	
Output Power Variation		Across any 2 MHz segment
Saturated Drive	≤0.3 dB p-p	
Unsaturated Drive	≤0.5 dB p-p	
Group Delay Stability	≤ 1.5 ns rms	Ranging modulation signal path over 8 h period (see module 203)
Spurious Output		Below carrier
1–10 Hz	–50 dB	

Table 3. X-Band Transmit Characteristics, DSS-24, -25, -26, -34, -35, -36, -54, and -55 (continued)

Parameter	Value	Remarks
10 Hz–1.5 MHz	–60 dB	
1.5 MHz–8 MHz	–45 dB	
2nd Harmonic	–75 dB	
3rd, 4th & 5th Harmonics	–60 dB	

Table 4. Ka-Band Transmit Characteristics, DSS-25

Parameter	Value	Remarks
ANTENNA		
Gain at 34300 MHz		At peak of gain versus elevation angle curve, referenced to feedhorn aperture for matched polarization; no atmosphere included; triangular PDF tolerance.
Ka-only mode	79.52 +0.2,-0.3 dBi	
X/Ka-mode	79.37 +0.2,-0.3 dBi	
Transmitter Waveguide Loss	0.25 ±0.1 dB	300 W transmitter output terminal (waterload switch) to feedhorn aperture
Half-Power Beamwidth	0.016 ±0.001 deg	Angular width (2-sided) between half-power points at specified frequency
Polarization	LCP	RCP is available by changing mechanical configuration of feed
Ellipticity	1.0 dB (max)	Peak-to-peak axial ratio. See Table 2 for definition.
Pointing Loss	0.12 dB	Monopulse aided tracking with minimum required signal level
Angular	See module 302	See also Figure 43 and Figure 44.

Table 4. Ka-Band Transmit Characteristics, DSS-25 (continued)

Parameter	Value	Remarks
EXCITER AND TRANSMITTER		
Frequency range covered		
Exciter	34200-34700 MHz	
Transmitter	34315-34415 MHz	
Coherent with deep space Ka-band D/L channels	34317.8-34406.3 MHz	3360/3599 turnaround ratio
Coherent with deep space X-band D/L channels	34354.3-34409.8 MHz	880/3599 turnaround ratio
RF Power Output	47.0–54.8 ±0.5 dBm	Referenced to 300 W transmitter output terminal (transmitter RF drawer rear panel flange). Settability is limited to 0.25 dB by measurement equipment precision.
Minimum power output is about 47 dBm (50 W) and may operate unsaturated.		
EIRP (maximum)	134.0 +0.6, -0.5 dBm	At gain set elevation angle, referenced to feedhorn aperture
Output Power Variation	≤ ±1.0 dB	Across frequency band over 8 hours
Spurious Output		Below carrier
1–10 Hz	–50 dB	
10 Hz–1.5 MHz	–60 dB	
1.5 MHz–8 MHz	–45 dB	

Table 5. S- and K-Band Receive Characteristics, DSS-24, -34, -36, and -54

Parameter	Value	Remarks
ANTENNA		
Gain		At peak of gain versus elevation angle curve, referenced to feedhorn aperture (feed and feedline losses are accounted for in system temperature), for matched polarization; no atmosphere included; triangular PDF tolerance. See Figure 7 and Figure 15 – Figure 17 for representative gain versus elevation curves.
S-band (2295 MHz)	56.84 +0.1,-0.2 dBi 56.63 +0.1,-0.2 dBi	DSS-24, -34, -54 DSS-36
K-band (26000 MHz)	77.2 +0.0,-0.2 dBi	Not available at DSS-36
Half-Power Beamwidth		Angular width (2-sided) between half-power points at specified frequency
S-band	0.242 ±0.020 deg	
K-band	0.021 ±0.002 deg	
Polarization	RCP or LCP	Remotely selected. S-band must be same as transmit polarization
Ellipticity	≤1.0 dB	Peak-to-peak voltage axial ratio, RCP and LCP. See definition in Table 2.
Pointing Loss		
Angular	See module 302	See also Figure 41 and Figure 43.
CONSCAN	0.1 dB	Recommended value for S-, X, or K-band tracking

**Table 5. S- and K-Band Receive Characteristics, DSS-24, -34, -36, and -54
(continued)**

Parameter	Value	Remarks
S-BAND RECEIVER		
Frequency Range Covered	2200–2300 MHz	
Recommended Maximum Signal Power	-85.0 dBm	At HEMT input terminal
Antenna-Microwave Noise Temperature (T_{AMW})		Near zenith, no atmosphere or cosmic noise included. See Table 9 and Figure 24. Favorable (–) and adverse (+) tolerances have triangular PDF.
Non-Diplexed Path		Referenced to feedhorn aperture. LNA = HEMT-1
DSS-24	26.10 –1.0,+2.0 K	
DSS-34	24.88 –1.0,+2.0 K	
DSS-36	21.57 –1.0,+2.0 K	
DSS-54	25.73 –1.0,+2.0 K	
Diplexed Path		Referenced to feedhorn aperture. LNA = HEMT-1
DSS-24	33.47 –1.0,+2.0 K	
DSS-34	34.46 –1.0,+2.0 K	
DSS-36	30.43 –1.0,+2.0 K	
DSS-54	35.35 –1.0,+2.0 K	
Tunability	Continuous	
Carrier Tracking Loop Noise B/W (Hz)	0.25 – 200	Effective one-sided, noise-equivalent carrier loop bandwidth (B_L)

**Table 5. S- and K-Band Receive Characteristics, DSS-24, -34, -36, and -54
(continued)**

Parameter	Value	Remarks
K-BAND RECEIVER		
Frequency Range Covered	25500–27000 MHz	
Recommended Maximum Signal Power		At HEMT input terminal
Normal Mode	–85.0 dBm	
Low-gain Mode	–65.0 dBm	For high received power levels
Antenna-Microwave Noise Temperature (T_{AMW})		RCP/LCP average at 26000 MHz. Referenced to feedhorn aperture. See Table 9 and Figures 32-34.
DSS-24 K-only mode	20.7 –1.0,+3.0 K	
DSS-24 S/K-mode	26.5 –1.0,+3.0 K	
DSS-34 K-only mode	25.6 –1.0,+3.0 K	
DSS-34 S/K-mode	31.4 –1.0,+3.0 K	
DSS-36	K-band not available	
DSS-54 K-only mode	28.8 –1.0,+3.0 K	
DSS-54 S/K-mode	34.6 –1.0,+3.0 K	
Low-Gain Mode		Required for signal levels in excess of –85.0 dBm
K-only (All Stations)	156 –11.0,+33.0 K	
S/K-only (All Stations)	185 –11.0,+33.0 K	
Tunability	1 Hz resolution	
Carrier Tracking Loop Noise B/W	0.1% of symbol rate	Effective one-sided, noise-equivalent carrier loop bandwidth (B_L)
Symbol Loop Acquisition B/W	0.3% of symbol rate	

Table 6. X-Band Receive Characteristics, DSS-24

Parameter	Value	Remarks
MAIN ANTENNA		
Gain (8420 MHz)		At peak of gain versus elevation angle curve, referenced to feedhorn aperture (feed and feedline losses are accounted for in system temperature), for matched polarization; no atmosphere included; triangular PDF tolerance.
X-only Mode	68.24 +0.1,-0.2 dBi	S/X and S/K dichroic plates retracted.
S/X Mode	68.19 +0.1,-0.2 dBi	S/X dichroic plate extended.
Half-Power Beamwidth	0.066 ±0.004 deg	Angular width (2-sided) between half-power points at specified frequency
Polarization	RCP or LCP	Remotely Selected. Same as or opposite from transmit polarization
Ellipticity	≤0.7 dB	Peak-to-peak voltage axial ratio, RCP and LCP. See definition in Table 2.
Pointing Loss		
Angular	See module 302	See also Figure 42.
CONSCAN	0.1 dB	Recommended value when using X-band CONSCAN reference

Table 6. X-Band Receive Characteristics, DSS-24 (continued)

Parameter	Value	Remarks
RECEIVER		
Frequency Range Covered	8400–8500 MHz	
Recommended Maximum Signal Power	-90.0 dBm	At maser input terminal
Antenna-Microwave Noise Temperature (T_{AMW})	Low-gain mode add +20 K to values below	Near zenith, no atmosphere or cosmic noise included. See Table 9. Favorable (–) and adverse (+) tolerances have triangular PDF.
Non-Diplexed Path (8400–8500 MHz) LNA = MASER-1	21.28 –1.0,+2.0 K	X-band-only operation (S/X-band dichroic plate retracted). Referenced to feedhorn aperture.
Diplexed Path (8400–8500 MHz) LNA = MASER-1	30.39 –1.0,+2.0 K	X-band-only operation (S/X-band dichroic plate retracted). Referenced to feedhorn aperture.
Non-Diplexed Path (8400–8500 MHz) LNA = MASER-1	22.72 –1.0,+2.0 K	S/X-band operation (S/X-band dichroic plate extended). Referenced to feedhorn aperture.
Diplexed Path (8400–8500 MHz) LNA = MASER-1	31.89 –1.0,+2.0 K	S/X-band operation (S/X-band dichroic plate extended). Referenced to feedhorn aperture.
Tunability	Continuous	
Carrier Tracking Loop Noise B/W (Hz)	0.25 – 200	Effective one-sided, noise-equivalent carrier loop bandwidth (B_L)
ACQUISITION ANTENNA AND RECEIVER – DSS-24		
Gain (8420 MHz)	38.0 ±0.5 dB	Referenced to acquisition downconverter input terminals (includes feedline losses)
Half-Power Beamwidth	2.1 deg	Angular width (2-sided) between half-power points at specified frequency
Polarization	RCP	LCP is available by manual selection at feed
Frequency Range Covered	8400–8500 MHz	
System Temperature	280 ±30K.	Near Zenith
Tracking Bandwidths		Two-sided bandwidths
Residual Carrier	4 kHz	
Frequency Acquisition	±150 kHz	
Doppler Tracking	±400 kHz	
Suppressed Carrier	280 kHz	Open-loop operation
Tunability	1 kHz resolution	
Signal Acquisition Range		
Residual Carrier	–90 to –135 dBm	
Suppressed Carrier	–90 to –119 dBm.	

Table 7. X- and Ka-Band Receive Characteristics, DSS-25, -26, -34, -35, -36, -54, and -55

Parameter	Value	Remarks
MAIN ANTENNA		
Gain		At peak of gain versus elevation angle curve, referenced to feedhorn aperture (feed and feedline losses are accounted for in system temperature), for matched polarization; no atmosphere included; triangular PDF tolerance. See Figures 8 – 14 and Figures 18 – 23 for representative gain versus elevation curves.
X-band (8420 MHz)	68.30 +0.1,-0.2 dBi	DSS-34, -36, & -54, S/X-band operation (S/X-band dichroic plate extended). DSS-25, -26, -35, -55 do not have S-band capability.
X-band (8420 MHz)	68.50 +0.1,-0.2 dBi	DSS-25, X/Ka-band operation (X/Ka-band dichroic plate extended).
	68.33 +0.1,-0.2 dBi	DSS-26, -34, -35, -36, -54, & -55, X/Ka-band operation.
Ka-band (32000 MHz)	79.00 +0.3,-0.3 dBi	DSS-25, Ka-band only operation (X/Ka-band dichroic plate retracted)
	78.85 +0.3,-0.3 dBi	DSS-25, X/Ka-band operation (X/Ka-band dichroic plate extended)
	79.18 +0.3,-0.3 dBi	DSS-26, -35, and -55 X/Ka-band operation
	78.98 +0.3,-0.3 dBi	DSS-34, X/Ka-band operation
	79.34 +0.3,-0.3 dBi	DSS-36, X/Ka-band operation
	78.38 +0.3,-0.3 dBi	DSS-54, X/Ka-band operation
Half-Power Beamwidth		Angular width (2-sided) between half-power points at specified frequency
X-band	0.066 ±0.004 deg	
Ka-band	0.017 ±0.002 deg	
Polarization		
X-band DSS-25	RCP and LCP	Both polarizations simultaneously available; polarizations of diplexed and non-diplexed paths are remotely selected
X-band DSS-26, -35, & -55	RCP and LCP	Simultaneously
X-band DSS-34 and -54	RCP or LCP	Remotely selected. Independent of transmit polarization.
Ka-band DSS-25	RCP	Monopulse is available only at RCP.
Ka-band DSS-26, -34, -35, -54, & -55	RCP and LCP	Monopulse is available only at RCP.

Table 7. X- and Ka-Band Receive Characteristics, DSS-25, -26, -34, -35, -36, -54, and -55 (continued)

Parameter	Value	Remarks
Ellipticity		Peak-to-peak voltage axial ratio. See definition in Table 2.
X-band	≤0.7 dB	RCP and LCP
Ka-band	≤1.0 dB	
Pointing Loss		
Angular	See module 302	See also Figures 42 and 43.
CONSCAN		
X-band	0.1 dB	Recommended value when using X-band CONSCAN
Ka-band	0.1 dB	Recommended value when using Ka-band CONSCAN if monopulse not available or for dual-polarization Ka-band reception.
Monopulse		
X-band	0.007 dB	Using Ka-band monopulse reference
Ka-band	0.11 dB	Sum channel signal to error channel noise ratio ≥ 26 dB-Hz
RECEIVER		
Frequency Ranges		
X-band	8200-8600 MHz	General frequency range. Specific antenna bandwidth restrictions listed below.
Ka-band	31800–32300 MHz	Tracking receiver covers bandwidth with 5 overlapping bands of ≈ 160 MHz
Recommended Maximum Signal Power	-90.0 dBm -85.0 dBm -65.0 dBm	At maser input terminal (DSS-25) At HEMT input terminal (DSS-25, -26, -34, -35, -36, -54, -55) At HEMT input terminal (DSS-25, -26, -34, -35, -36, -54, -55) for high received power level in low-gain mode.
Antenna-Microwave Noise Temperature (T_{AMW})	Low-gain mode add +20 K for X-band, +70 K for Ka-band, to values below	Near zenith, no atmosphere or cosmic noise included. See Table 9. See Figures 25–31 and Figures 35–40 for representative system temperature versus elevation curves. Favorable (–) and adverse (+) tolerances have triangular PDF.
X-band (with bandwidth restrictions)		DSS-25 with conventional maser/HEMT configuration. With or without transmitter operating. Referenced to feedhorn aperture.

Table 7. X- and Ka-Band Receive Characteristics, DSS-25, -26, -34, -35, -36, -54, and -55 (continued)

Parameter	Value	Remarks
DSS-25 (RCP or LCP) (8400-8500 MHz)	20.20 -1.0,+2.0 K	LNA = MASER-1, non-diplexed
DSS-25 (RCP or LCP) (8200-8600 MHz)	35.06 -1.0,+2.0 K	LNA = HEMT-1, non-diplexed
DSS-25 (RCP or LCP) (8400-8500 MHz)	29.26 -1.0,+2.0 K	LNA = MASER-1, diplexed
DSS-25 (RCP or LCP) (8200-8600 MHz)	44.88 -1.0,+2.0 K	LNA = HEMT-1, diplexed
X-band (8200-8600 MHz)		DSS-26, -34, -35, -54, -55 with always-diplexed dual-HEMT X/X/Ka feed. With or without transmitter operating. Referenced to feedhorn aperture.
DSS-26 (RCP)	16.29 -1.0,+2.0 K	LNA = HEMT-1
DSS-26 (LCP)	15.43 -1.0,+2.0 K	LNA = HEMT-2
DSS-34 (RCP)	16.28 -1.0,+2.0 K	X/Ka operation, LNA = HEMT-1
DSS-34 (LCP)	16.71 -1.0,+2.0 K	X/Ka operation, LNA = HEMT-2
DSS-34 (RCP)	17.99 -1.0,+2.0 K	S/X operation, LNA = HEMT-1
DSS-34 (LCP)	18.43 -1.0,+2.0 K	S/X operation, LNA = HEMT-2
DSS-35 (RCP)	14.7 -1.0,+2.0 K	LNA = HEMT-1
DSS-35 (LCP)	15.0 -1.0,+2.0 K	LNA = HEMT-2
DSS-36 (RCP)	12.59 -1.0,+2.0 K	X/Ka operation, LNA = HEMT-1
DSS-36 (LCP)	13.95 -1.0,+2.0 K	X/Ka operation, LNA = HEMT-2
DSS-36 (RCP)	14.31 -1.0,+2.0 K	S/X operation, LNA = HEMT-1
DSS-36 (LCP)	15.67 -1.0,+2.0 K	S/X operation, LNA = HEMT-2
DSS-54 (RCP)	18.31 -1.0,+2.0 K	X/Ka operation, LNA = HEMT-1
DSS-54 (LCP)	18.31 -1.0,+2.0 K	X/Ka operation, LNA = HEMT-2
DSS-54 (RCP)	20.03 -1.0,+2.0 K	S/X operation, LNA = HEMT-1
DSS-54 (LCP)	20.03 -1.0,+2.0 K	S/X operation, LNA = HEMT-2
DSS-55 (RCP)	17.42 -1.0,+2.0 K	LNA = HEMT-1
DSS-55 (LCP)	17.82 -1.0,+2.0 K	LNA = HEMT-2
Ka-band (31800-32300 MHz)		Ka-band only operation (X/Ka-band dichroic plate at DSS-25 retracted), referenced to feedhorn aperture,
DSS-25 (RCP)	27.89 -1.0,+2.0 K	LNA = HEMT-1
DSS-25 (RCP Error)	27.30 -1.0,+2.0 K	LNA = HEMT-2
Ka-band (31800-32300 MHz)		X/Ka-band operation (X/Ka-band dichroic plate at DSS-25 extended), referenced to feedhorn aperture,
DSS-25 (RCP)	31.41 -1.0,+2.0 K	LNA = HEMT-1

Table 7. X- and Ka-Band Receive Characteristics, DSS-25, -26, -34, -35, -36, -54, and -55 (continued)

Parameter	Value	Remarks
DSS-25 (RCP Error)	35.53 $-1.0,+2.0$ K	LNA = HEMT-2
Ka-band (31800–32300 MHz)		X/Ka-band operation referenced to feedhorn aperture
DSS-26 (RCP)	19.36 $-1.0,+2.0$ K	LNA = HEMT-1
DSS-26 (RCP Error)	24.55 $-1.0,+2.0$ K	LNA = HEMT-2
DSS-26 (LCP)	20.77 $-1.0,+2.0$ K	LNA = HEMT-3
DSS-34 (RCP)	19.38 $-1.0,+2.0$ K	LNA = HEMT-1
DSS-34 (RCP Error)	23.25 $-1.0,+2.0$ K	LNA = HEMT-2
DSS-34 (LCP)	19.61 $-1.0,+2.0$ K	LNA = HEMT-3
DSS-35 (RCP)	17.3 $-1.0,+2.0$ K	LNA = HEMT-1
DSS-35 (RCP Error)	TBD	LNA = HEMT-2
DSS-35 (LCP)	17.2 $-1.0,+2.0$ K	LNA = HEMT-3
DSS-36 (RCP)	12.54 $-1.0,+2.0$ K	
DSS-36 (RCP Error)	TBD	
DSS-36 (LCP)	12.18 $-1.0,+2.0$ K	
DSS-54 (RCP)	21.80 $-1.0,+2.0$ K	LNA = HEMT-1
DSS-54 (RCP Error)	25.00 $-1.0,+2.0$ K	LNA = HEMT-2
DSS-54 (LCP)	21.80 $-1.0,+2.0$ K	LNA = HEMT-3
DSS-55 (RCP)	20.80 $-1.0,+2.0$ K	LNA = HEMT-1
DSS-55 (RCP Error)	21.98 $-1.0,+2.0$ K	LNA = HEMT-2
DSS-55 (LCP)	19.83 $-1.0,+2.0$ K	LNA = HEMT-3
Carrier Tracking Loop Noise B/W	0.25 – 200 Hz	Effective one-sided, noise-equivalent carrier loop bandwidth (B_L). See module 202

Table 7. X- and Ka-Band Receive Characteristics, DSS-25, -26, -34, -35, -36, -54, and -55 (continued)

Parameter	Value	Remarks
ACQUISITION ANTENNA AND RECEIVER - DSS-34 AND DSS-54		
Gain (8420 MHz)	38.0 ±0.5 dB	Referenced to acquisition downconverter input terminals (includes feedline losses)
Half-Power Beamwidth	2.1 deg	Angular width (2-sided) between half-power points at specified frequency
Polarization	RCP	LCP is available by manual selection at feed
Frequency Range Covered	8400–8500 MHz	
System Temperature	280 ±30K.	Near Zenith
Tracking Bandwidths		Two-sided bandwidths
Residual Carrier	4 kHz	
Frequency Acquisition	±150 kHz	
Doppler Tracking	±400 kHz	
Suppressed Carrier	280 kHz	Open-loop operation
Tunability	1 kHz resolution	
Signal Acquisition Range		
Residual Carrier	–90 to –135 dBm	
Suppressed Carrier	–90 to –119 dBm.	

Table 8. Gain Reduction Due to Wind Effects on Structural Deformation and Pointing Error

Wind Speed		Gain Reduction (dB)*			
(km/hr)	(mph)	S-Band	X-Band	K-Band	Ka-Band
10	6	negligible	negligible	0.02	0.03
30	18	negligible	0.02	0.19	0.29
50	30	negligible	0.06	0.53	0.80

* Maximum total combined effects of structural deformation and pointing error at various wind speeds.

Table 9. T_{AMW} , T_{sky} , and T_{op} for CD=25% Average Clear Weather at Zenith, Referenced to Feedhorn Aperture

Frequency, Station, and Configuration	Noise Temperatures, K		
	T_{AMW}	T_{sky}	T_{op}
S-band, DSS-24, S/X or S/K, HEMT-1, RCP or LCP, non-diplexed	26.10	4.68	30.78
S-band, DSS-24, S/X or S/K, HEMT-1, RCP or LCP, diplexed	33.47	4.68	38.15
S-band, DSS-34, S/X or S/K, HEMT-1, RCP or LCP, non-diplexed	24.88	4.86	29.74
S-band, DSS-34, S/X or S/K, HEMT-1, RCP or LCP, diplexed	34.46	4.86	39.32
S-band, DSS-36, S/X or S/K, HEMT-1, RCP or LCP, non-diplexed	21.57	4.86	26.43
S-band, DSS-36, S/X or S/K, HEMT-1, RCP or LCP, diplexed	30.43	4.86	35.29
S-band, DSS-54, S/X or S/K, HEMT-1, RCP or LCP, non-diplexed	25.73	4.80	30.53
S-band, DSS-54, S/X or S/K, HEMT-1, RCP or LCP, diplexed	35.35	4.80	40.15
X-band, DSS-24, X-only, MASER-1, RCP or LCP, non-diplexed	21.28	5.04	26.32
X-band, DSS-24, X-only, MASER-1, RCP or LCP, diplexed	30.39	5.04	35.43
X-band, DSS-24, S/X, MASER-1, RCP or LCP, non-diplexed	22.72	5.04	27.76
X-band, DSS-24, S/X, MASER-1, RCP or LCP, diplexed	31.89	5.04	36.93
X-band, DSS-25, X/Ka, MASER-1, RCP or LCP, non-diplexed	20.20	5.04	25.24
X-band, DSS-25, X/Ka, HEMT-1, RCP or LCP, non-diplexed	35.06	5.04	40.10
X-band, DSS-25, X/Ka, MASER-1, RCP or LCP, diplexed	29.26	5.04	34.30
X-band, DSS-25, X/Ka, HEMT-1, RCP or LCP, diplexed	44.88	5.04	49.92
X-band, DSS-26, X/Ka, HEMT-1, RCP, diplexed	16.29	5.04	21.33
X-band, DSS-26, X/Ka, HEMT-2, LCP, diplexed	15.43	5.04	20.47
X-band, DSS-34, X/Ka, HEMT-1, RCP, diplexed	16.28	5.33	21.61
X-band, DSS-34, X/Ka, HEMT-2, LCP, diplexed	16.71	5.33	22.04
X-band, DSS-34, S/X, HEMT-1, RCP, diplexed	17.99	5.33	23.32
X-band, DSS-34, S/X, HEMT-2, LCP, diplexed	18.43	5.33	23.76
X-band, DSS-35, X/Ka, HEMT-1, RCP, diplexed	14.7	5.33	20.0
X-band, DSS-35, X/Ka, HEMT-2, LCP, diplexed	15.0	5.33	20.3
X-band, DSS-36, X/Ka, HEMT-1, RCP, diplexed	12.59	5.33	17.92
X-band, DSS-36, X/Ka, HEMT-2, LCP, diplexed	13.95	5.33	19.28
X-band, DSS-36, S/X, HEMT-1, RCP, diplexed	14.31	5.33	19.64
X-band, DSS-36, S/X, HEMT-2, LCP, diplexed	15.67	5.33	21.00
X-band, DSS-54, X/Ka, HEMT-1, RCP, diplexed	18.31	5.21	23.52
X-band, DSS-54, X/Ka, HEMT-2, LCP, diplexed	18.31	5.21	23.52
X-band, DSS-54, S/X, HEMT-1, RCP, diplexed	20.03	5.21	25.24
X-band, DSS-54, S/X, HEMT-2, LCP, diplexed	20.03	5.21	25.24
X-band, DSS-55, X/Ka, HEMT-1, RCP, diplexed	17.42	5.21	22.63
X-band, DSS-55, X/Ka, HEMT-2, LCP, diplexed	17.82	5.21	23.03

Table 9. TAMW, Tsky, and Top for CD=25% Average Clear Weather at Zenith, Referenced to Feedhorn Aperture (continued)

Frequency, Station, and Configuration	Noise Temperatures, K		
	T_{AMW}	T_{sky}	T_{op}
K-band, DSS-24, K-only, HEMT-1, RCP, non-diplexed, 25.5 GHz	19.8	10.3	30.1
K-band, DSS-24, K-only, HEMT-2, LCP, non-diplexed, 25.5 GHz	27.3	10.3	37.6
K-band, DSS-24, S/K, HEMT-1, RCP, non-diplexed, 25.5 GHz	30.4	10.3	40.7
K-band, DSS-24, S/K, HEMT-2, LCP, non-diplexed, 25.5 GHz	37.9	10.3	48.2
K-band, DSS-24, K-only, HEMT-1, RCP, non-diplexed, 26.0 GHz	17.7	10.1	27.8
K-band, DSS-24, K-only, HEMT-2, LCP, non-diplexed, 26.0 GHz	23.7	10.1	33.8
K-band, DSS-24, S/K, HEMT-1, RCP, non-diplexed, 26.0 GHz	23.6	10.1	33.7
K-band, DSS-24, S/K, HEMT-2, LCP, non-diplexed, 26.0 GHz	29.6	10.1	39.7
K-band, DSS-24, K-only, HEMT-1, RCP, non-diplexed, 27.0 GHz	21.0	10.1	31.1
K-band, DSS-24, K-only, HEMT-2, LCP, non-diplexed, 27.0 GHz	25.6	10.1	35.7
K-band, DSS-24, S/K, HEMT-1, RCP, non-diplexed, 27.0 GHz	30.6	10.1	40.7
K-band, DSS-24, S/K, HEMT-2, LCP, non-diplexed, 27.0 GHz	35.2	10.1	45.3
K-band, DSS-34, K-only, HEMT-1, RCP, non-diplexed, 25.5 GHz	25.1	13.3	38.4
K-band, DSS-34, K-only, HEMT-2, LCP, non-diplexed, 25.5 GHz	26.5	13.3	39.8
K-band, DSS-34, S/K, HEMT-1, RCP, non-diplexed, 25.5 GHz	35.7	13.3	49.0
K-band, DSS-34, S/K, HEMT-2, LCP, non-diplexed, 25.5 GHz	37.1	13.3	50.4
K-band, DSS-34, K-only, HEMT-1, RCP, non-diplexed, 26.0 GHz	25.5	13.0	38.5
K-band, DSS-34, K-only, HEMT-2, LCP, non-diplexed, 26.0 GHz	25.6	13.0	38.6
K-band, DSS-34, S/K, HEMT-1, RCP, non-diplexed, 26.0 GHz	31.4	13.0	44.4
K-band, DSS-34, S/K, HEMT-2, LCP, non-diplexed, 26.0 GHz	31.5	13.0	44.5
K-band, DSS-34, K-only, HEMT-1, RCP, non-diplexed, 27.0 GHz	23.9	12.8	36.7
K-band, DSS-34, K-only, HEMT-2, LCP, non-diplexed, 27.0 GHz	24.7	12.8	37.5
K-band, DSS-34, S/K, HEMT-1, RCP, non-diplexed, 27.0 GHz	33.5	12.8	46.3
K-band, DSS-34, S/K, HEMT-2, LCP, non-diplexed, 27.0 GHz	34.3	12.8	47.1
K-band, DSS-54, K-only, HEMT-1, RCP, non-diplexed, 25.5 GHz	28.4	11.9	40.3
K-band, DSS-54, K-only, HEMT-2, LCP, non-diplexed, 25.5 GHz	30.9	11.9	42.8
K-band, DSS-54, S/K, HEMT-1, RCP, non-diplexed, 25.5 GHz	39.0	11.9	50.9
K-band, DSS-54, S/K, HEMT-2, LCP, non-diplexed, 25.5 GHz	41.5	11.9	53.4
K-band, DSS-54, K-only, HEMT-1, RCP, non-diplexed, 26.0 GHz	28.3	11.7	40.0
K-band, DSS-54, K-only, HEMT-2, LCP, non-diplexed, 26.0 GHz	29.2	11.7	40.9
K-band, DSS-54, S/K, HEMT-1, RCP, non-diplexed, 26.0 GHz	34.2	11.7	45.9
K-band, DSS-54, S/K, HEMT-2, LCP, non-diplexed, 26.0 GHz	35.1	11.7	46.8
K-band, DSS-54, K-only, HEMT-1, RCP, non-diplexed, 27.0 GHz	26.9	11.6	38.5
K-band, DSS-54, K-only, HEMT-2, LCP, non-diplexed, 27.0 GHz	26.8	11.6	38.4
K-band, DSS-54, S/K, HEMT-1, RCP, non-diplexed, 27.0 GHz	36.5	11.6	48.1

Table 9. TAMW, Tsky, and Top for CD=25% Average Clear Weather at Zenith, Referenced to Feedhorn Aperture (continued)

Frequency, Station, and Configuration	Noise Temperatures, K		
	T_{AMW}	T_{sky}	T_{op}
K-band, DSS-54, S/K, HEMT-2, LCP, non-diplexed, 27.0 GHz	36.4	11.6	48.0
Ka-band, DSS-25, Ka-only, HEMT-1, RCP, diplexed	27.89	11.44	39.33
Ka-band, DSS-25, Ka-only, HEMT-2, RCP-error, diplexed	27.30	11.44	38.74
Ka-band, DSS-25, X/Ka, HEMT-1, RCP, diplexed	31.41	11.44	42.85
Ka-band, DSS-25, X/Ka, HEMT-2, RCP-error, diplexed	35.53	11.44	46.97
Ka-band, DSS-26, X/Ka, HEMT-1, RCP, non-diplexed	19.36	11.44	30.80
Ka-band, DSS-26, X/Ka, HEMT-2, RCP-error, non-diplexed	24.55	11.44	35.99
Ka-band, DSS-26, X/Ka, HEMT-3, LCP, non-diplexed	20.77	11.44	32.21
Ka-band, DSS-34, X/Ka, HEMT-1, RCP, non-diplexed	19.38	14.08	33.46
Ka-band, DSS-34, X/Ka, HEMT-2, RCP-error, non-diplexed	23.25	14.08	37.33
Ka-band, DSS-34, X/Ka, HEMT-3, LCP, non-diplexed	19.61	14.08	33.69
Ka-band, DSS-35, X/Ka, HEMT-1, RCP, non-diplexed	17.3	14.08	31.4
Ka-band, DSS-35, X/Ka, HEMT-2, RCP-error, non-diplexed	TBD	14.08	TBD
Ka-band, DSS-35, X/Ka, HEMT-3, LCP, non-diplexed	17.2	14.08	31.3
Ka-band, DSS-36, X/Ka, HEMT-1, RCP, non-diplexed	12.54	14.08	26.62
Ka-band, DSS-36, X/Ka, HEMT-2, RCP-error, non-diplexed	TBD	14.08	TBD
Ka-band, DSS-36, X/Ka, HEMT-3, LCP, non-diplexed	12.18	14.08	26.26
Ka-band, DSS-54, X/Ka, HEMT-1, RCP, non-diplexed	21.80	13.28	35.08
Ka-band, DSS-54, X/Ka, HEMT-2, RCP-error, non-diplexed	25.00	13.28	38.28
Ka-band, DSS-54, X/Ka, HEMT-3, LCP, non-diplexed	21.80	13.28	35.08
Ka-band, DSS-55, X/Ka, HEMT-1, RCP, non-diplexed	20.80	13.28	34.08
Ka-band, DSS-55, X/Ka, HEMT-2, RCP-error, non-diplexed	21.98	13.28	35.26
Ka-band, DSS-55, X/Ka, HEMT-3, LCP, non-diplexed	19.83	13.28	33.11

NOTE: For low-gain mode add +20 K (X-band), +180 K (K-band), +70 K (Ka-band)

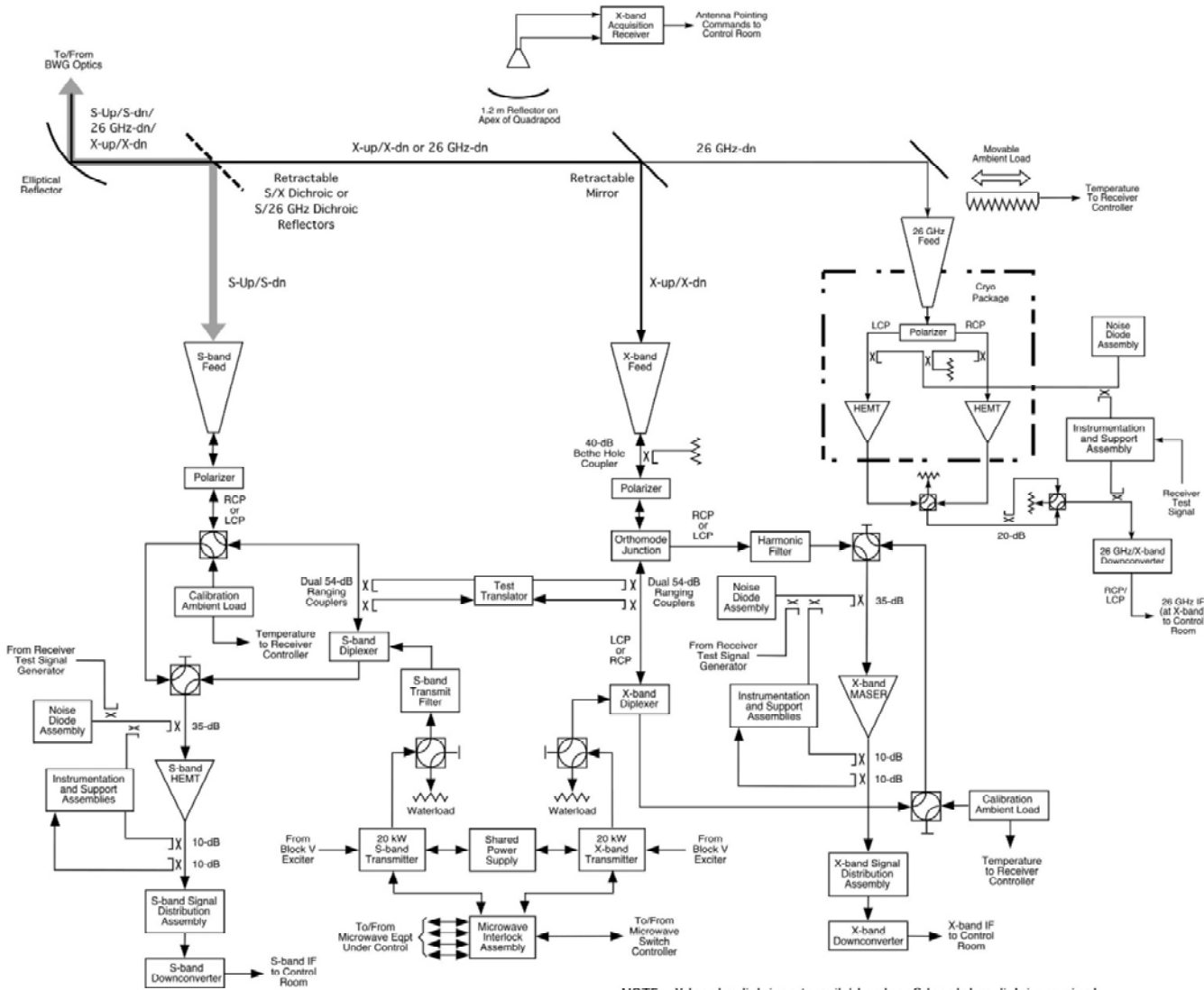

Figure 1. Functional Block Diagram of the DSS-24 Antenna

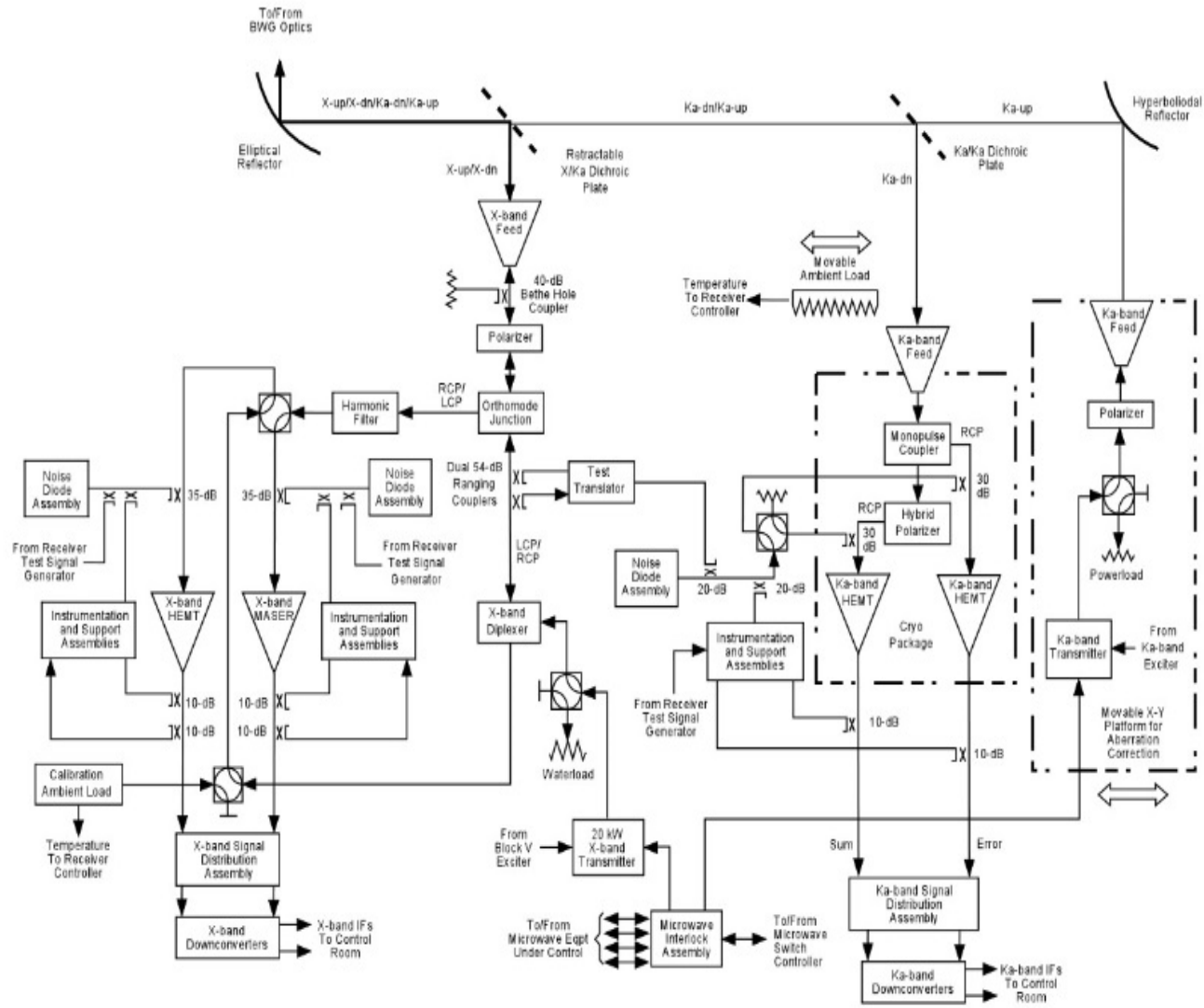

Figure 2. Functional Block Diagram of the DSS-25 Antenna

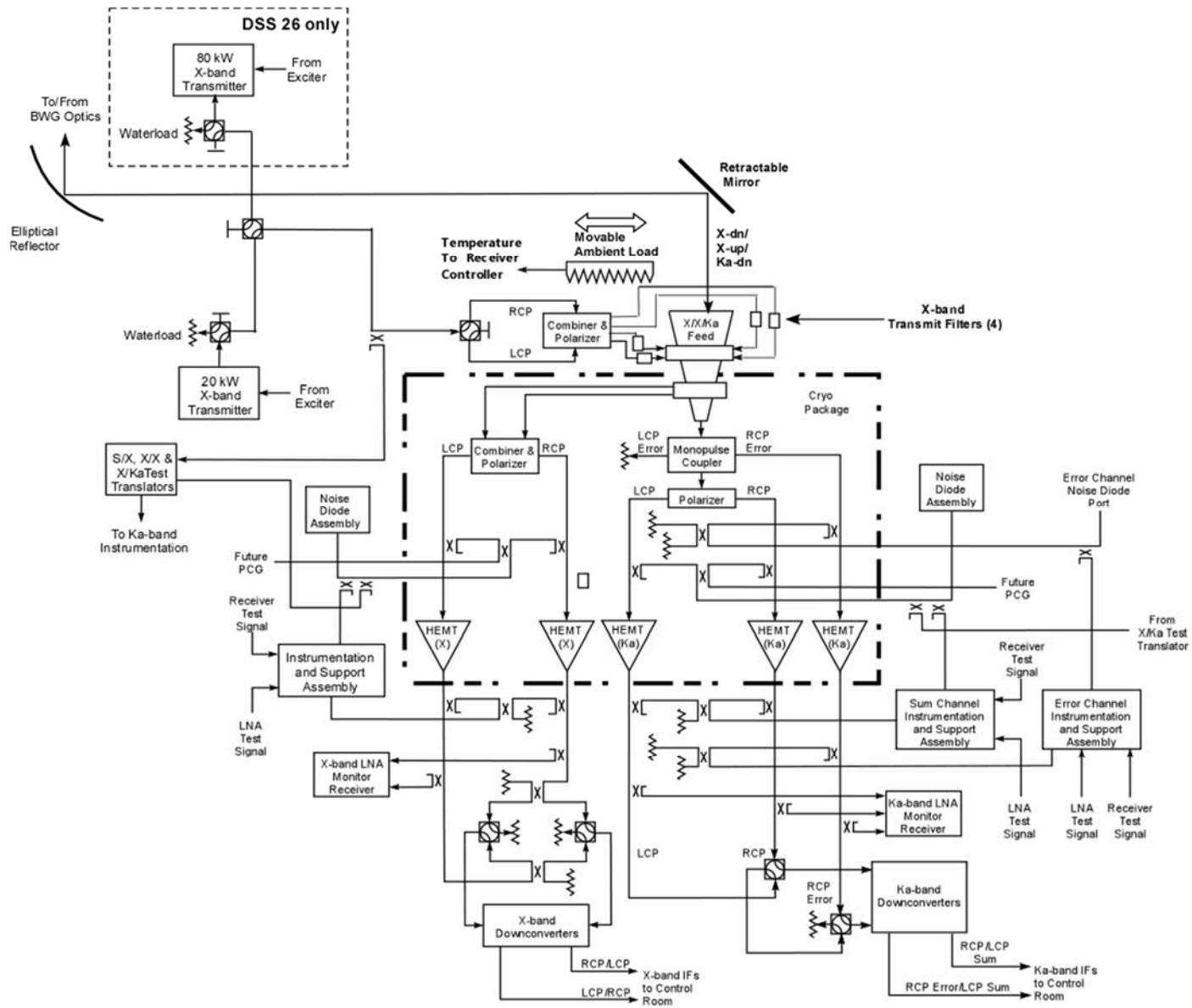

Figure 3. Functional Block Diagram of the DSS-26 and DSS-35 Antennas

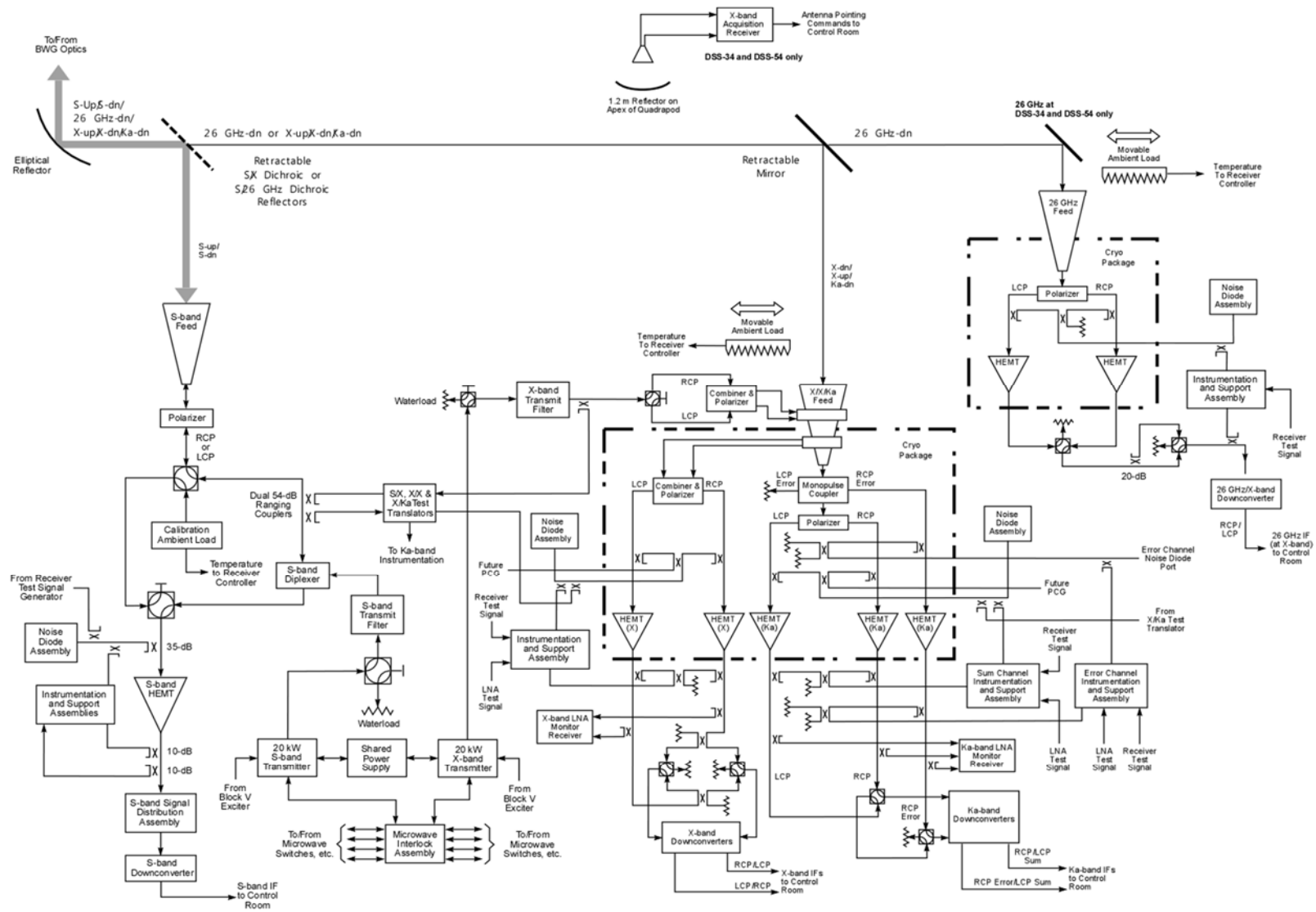

Figure 4. Functional Block Diagram of the DSS-34 and DSS-54 Antennas

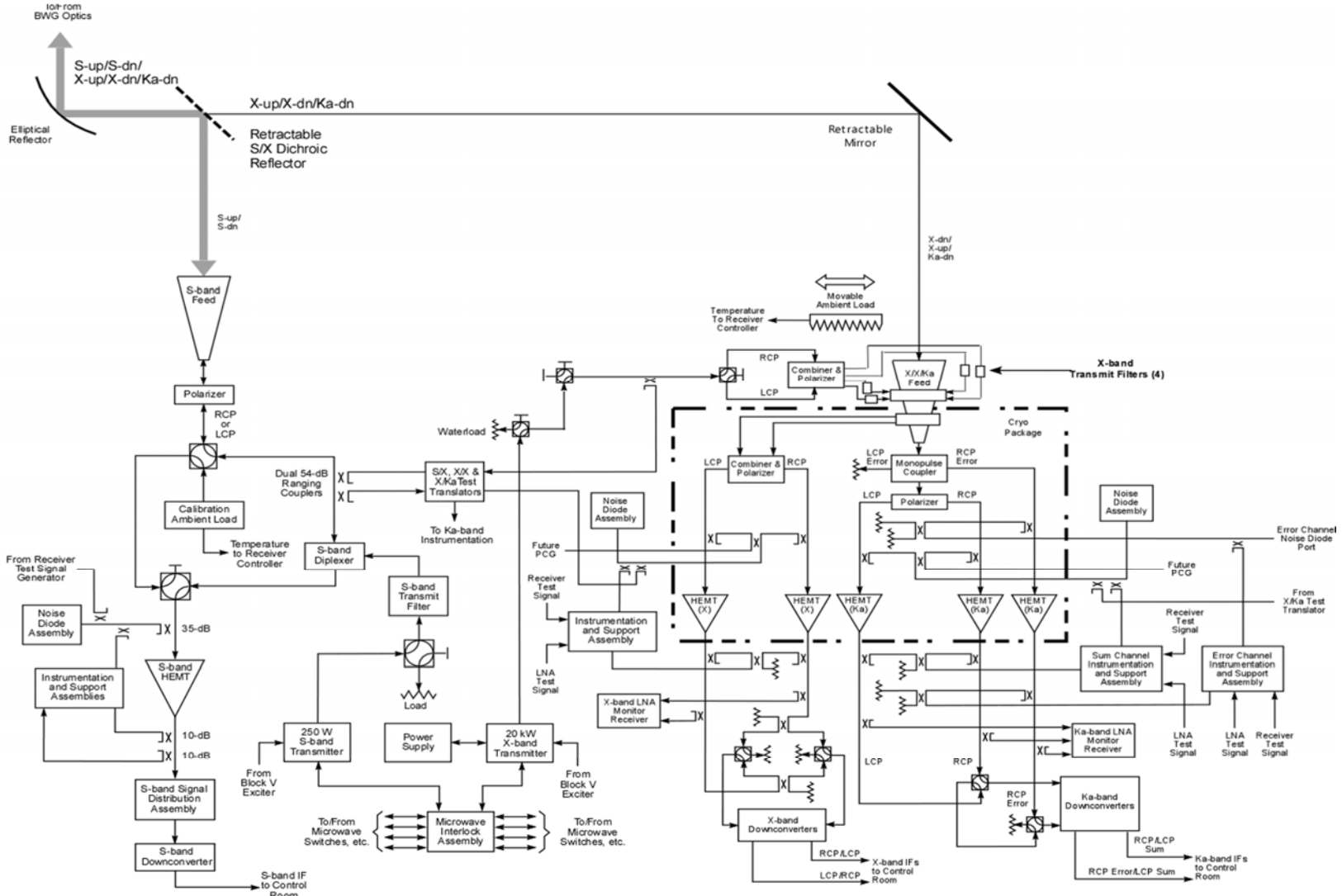

Figure 5. Functional Block Diagram of the DSS-36 Antenna

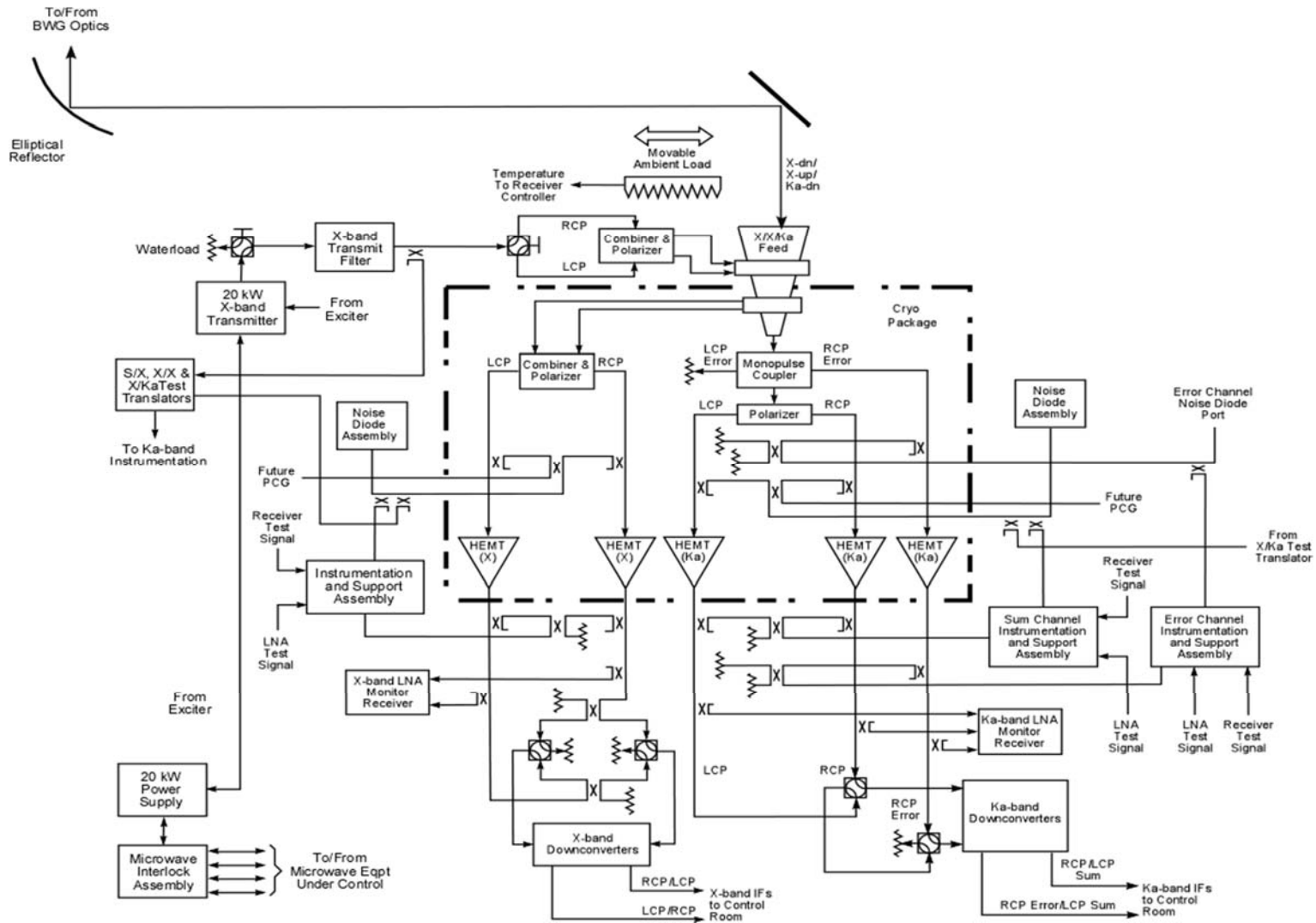

Figure 6. Functional Block Diagram of the DSS-55 Antenna

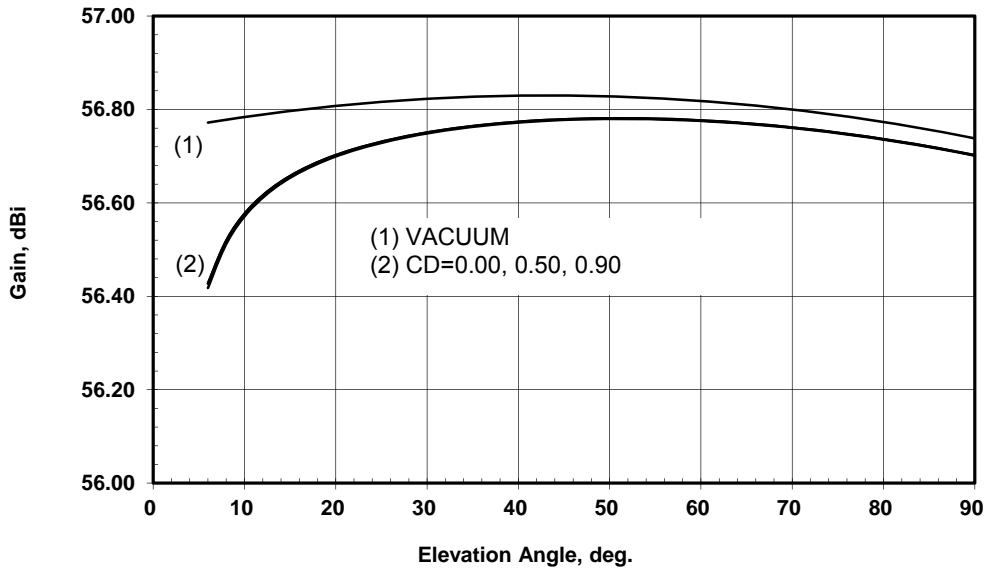

Figure 7. DSS-34 (Canberra) S-Band Receive Gain versus Elevation Angle, S/X-Mode (S/X Dichroic In Place), 2295 MHz

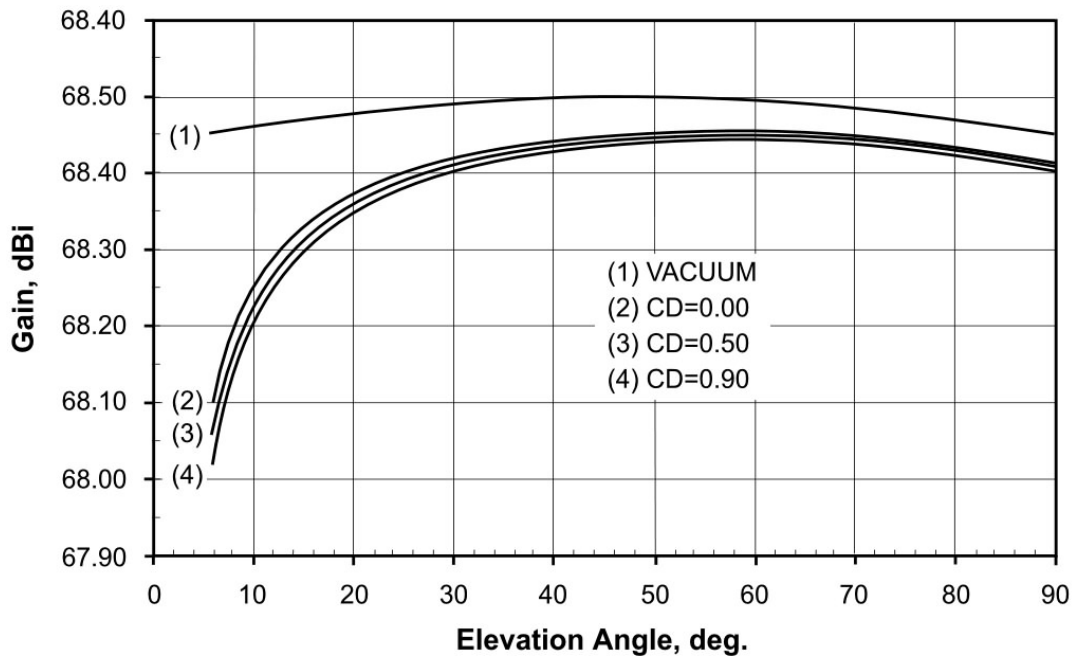

Figure 8. DSS-25 (Goldstone) X-Band Receive Gain versus Elevation Angle, X/Ka-Mode (X/Ka Dichroic In Place), 8420 MHz

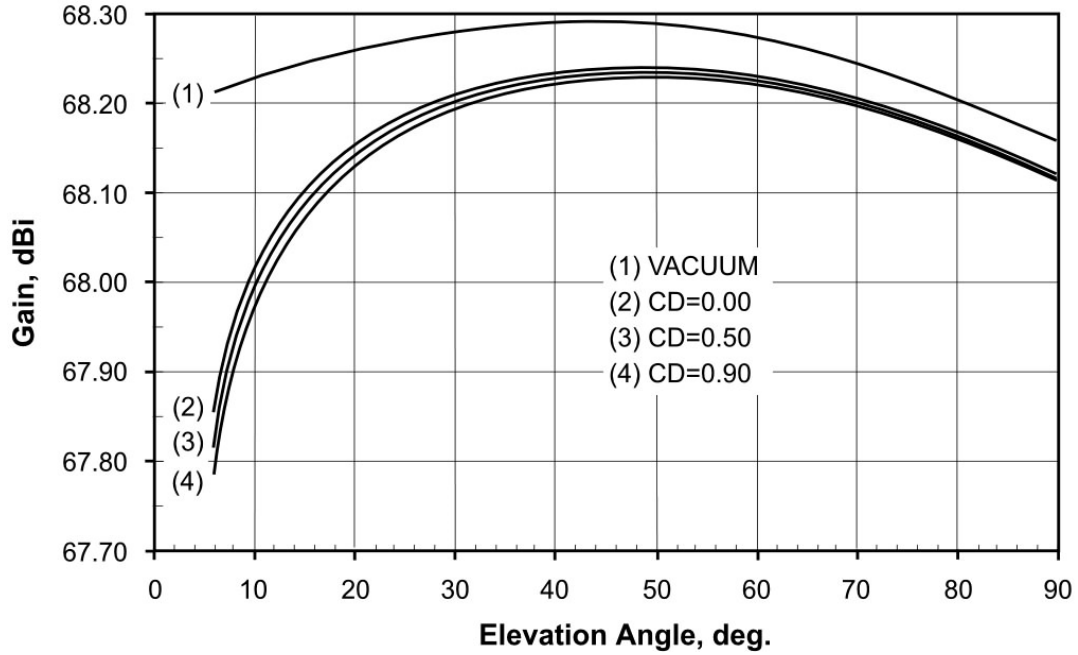

Figure 9. DSS-26 (Goldstone) X-Band Receive Gain versus Elevation Angle, X/Ka-Mode, 8420 MHz

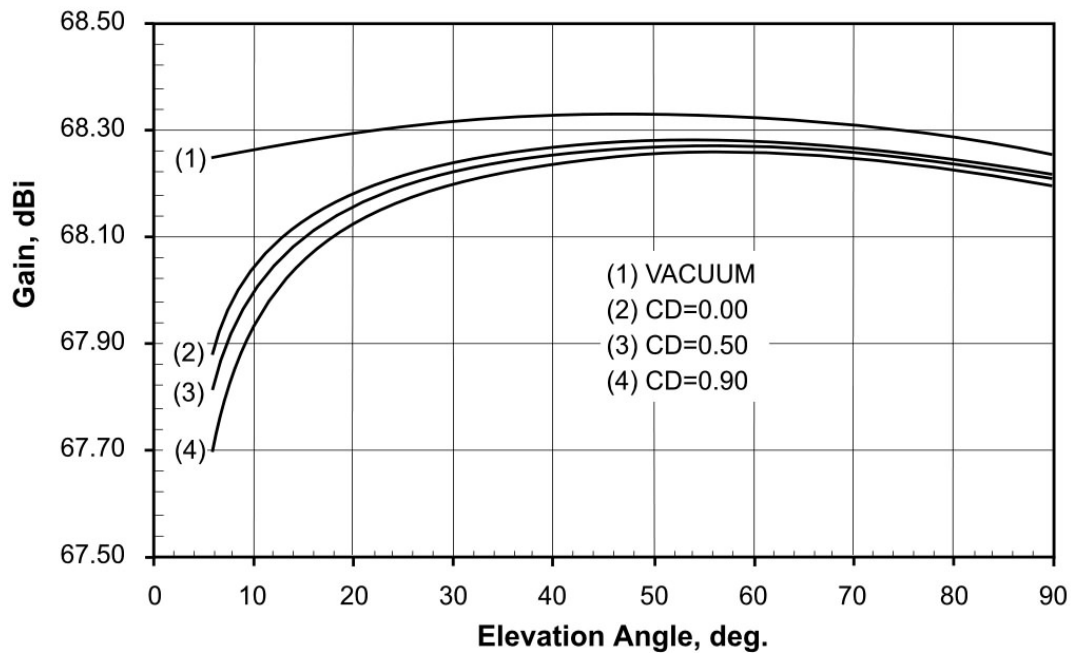

Figure 10. DSS-34 (Canberra) X-Band Receive Gain versus Elevation Angle, X/Ka-Mode (S/X Dichroic Retracted), 8420 MHz

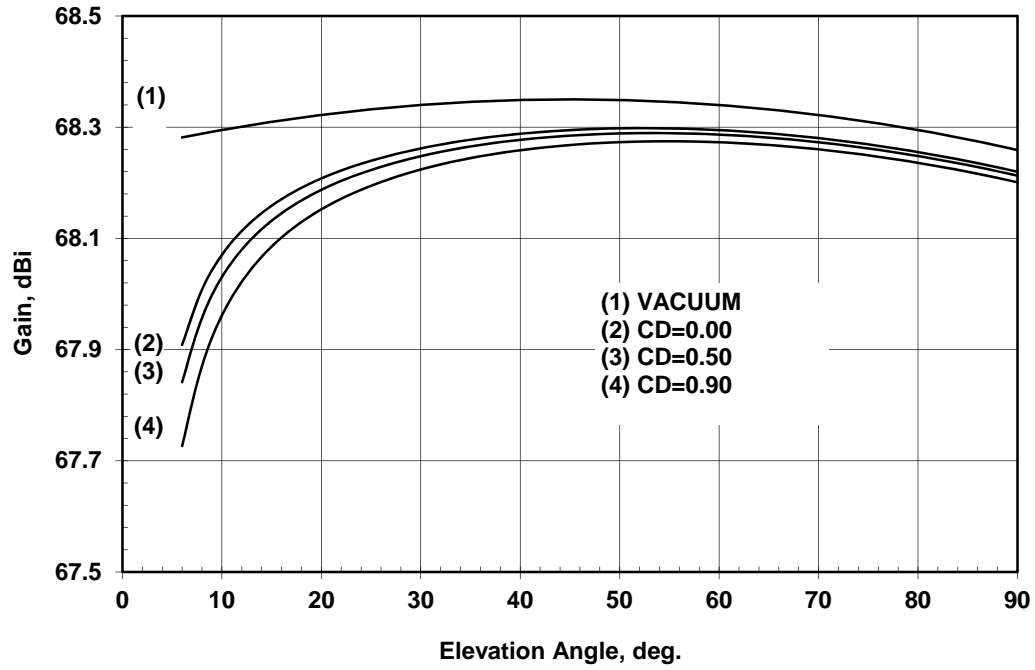

Figure 11. DSS-35 (Canberra) X-Band Receive Gain versus Elevation Angle, X/Ka-Mode, 8420 MHz

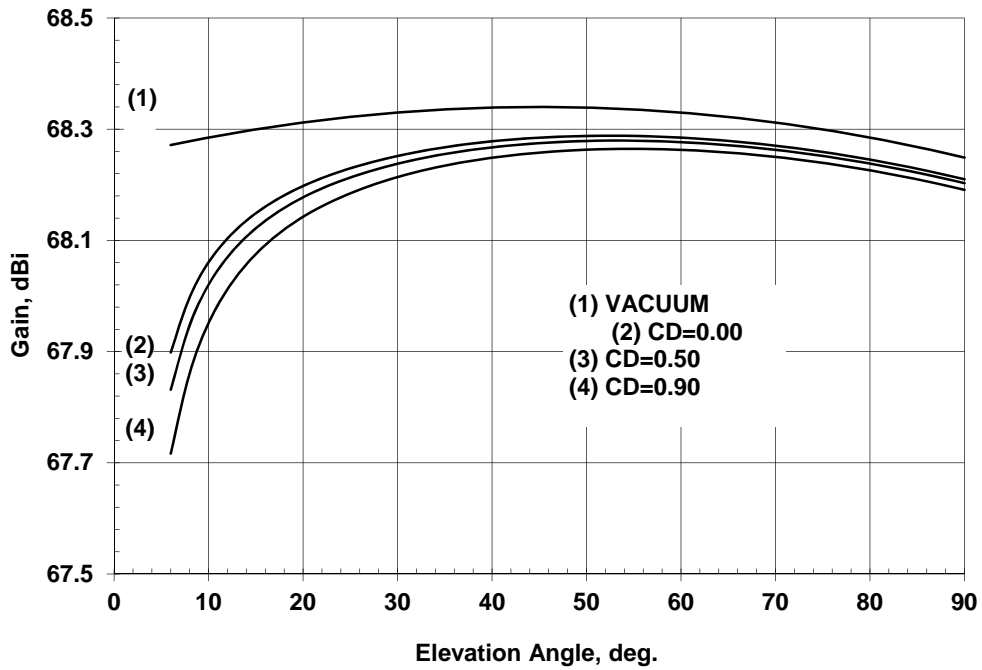

Figure 12. DSS-36 (Canberra) X-band Receive Gain versus Elevation Angle, X/Ka-Mode, 8420 MHz

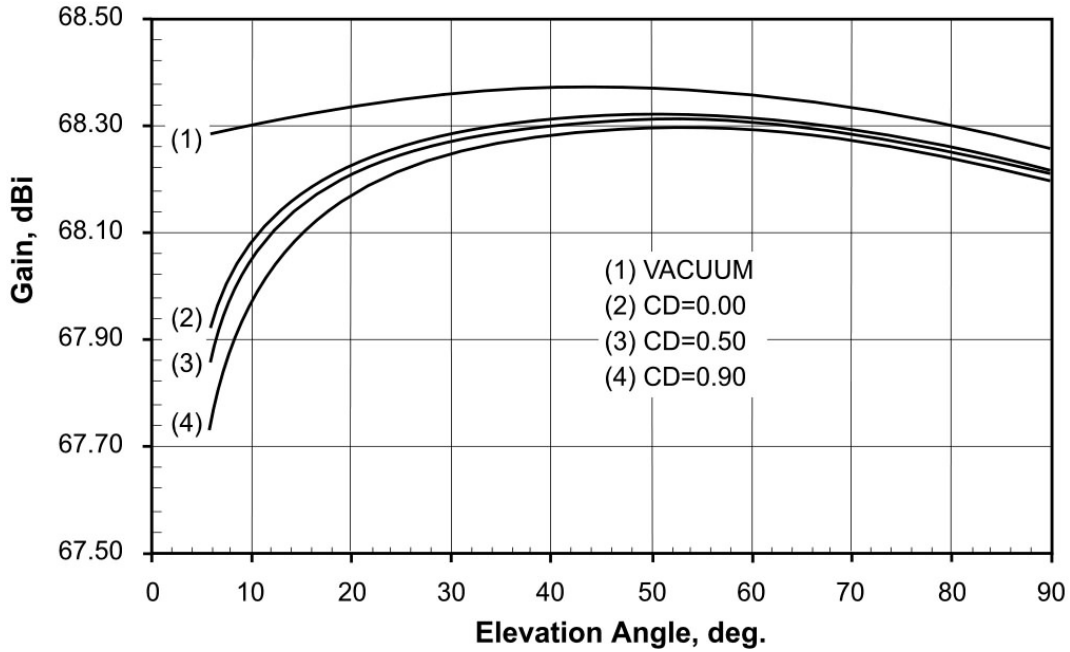

Figure 13. DSS-54 (Madrid) X-Band Receive Gain versus Elevation Angle, X/Ka-Mode (S/X Dichroic Retracted), 8420 MHz

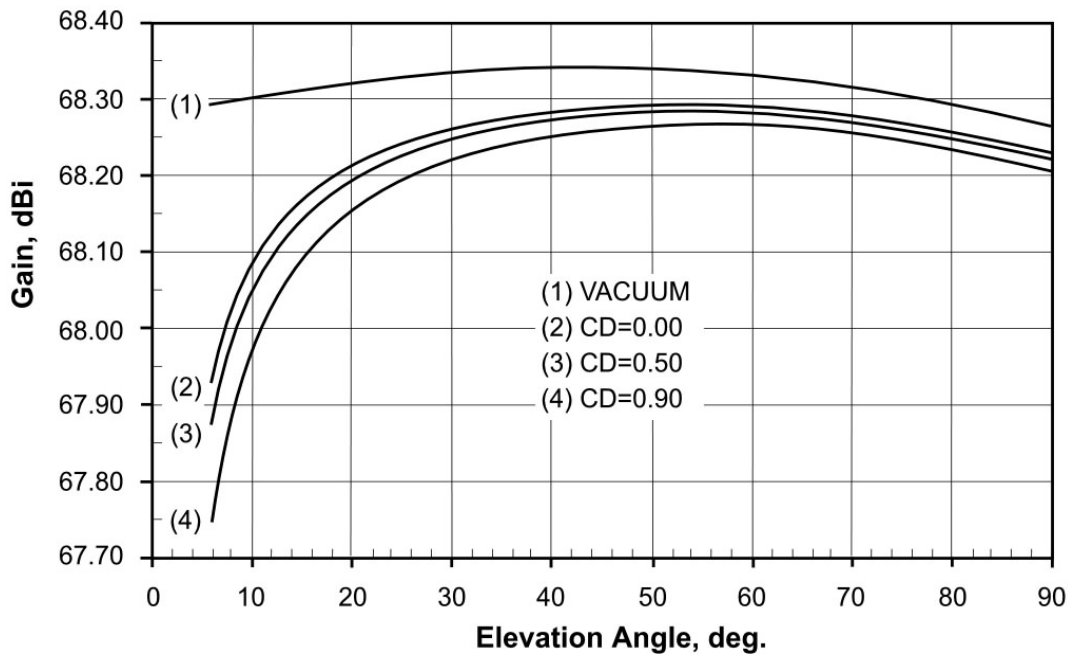

Figure 14. DSS-55 (Madrid) X-Band Receive Gain versus Elevation Angle, X/Ka Mode, 8420 MHz

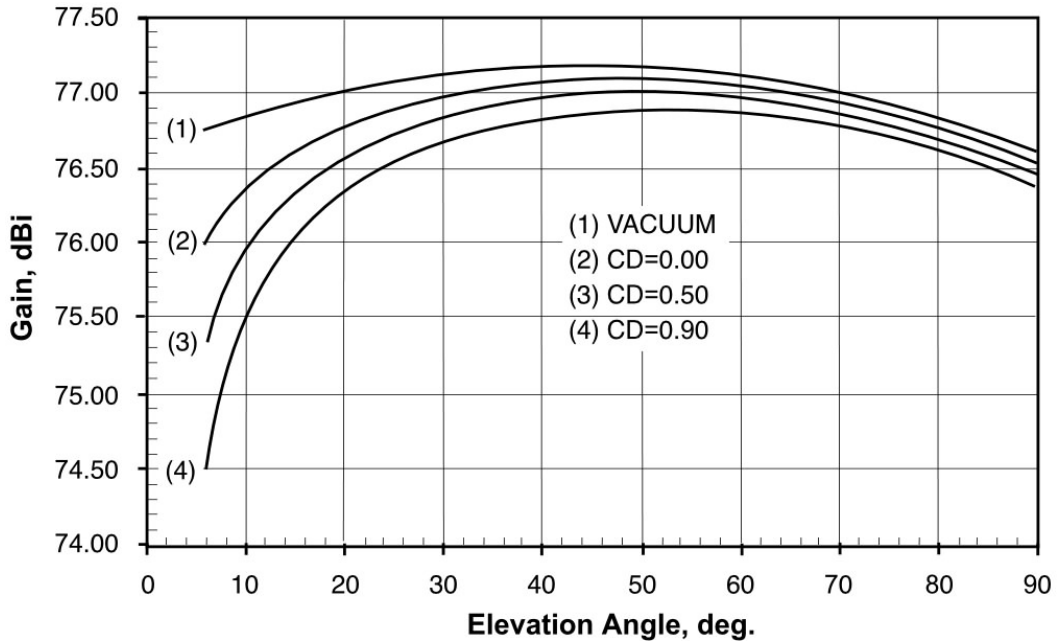

Figure 15. DSS-24 (Goldstone) K-Band Receive Gain versus Elevation Angle, K-Only Mode (S/K Dichroic Retracted), 26000 MHz

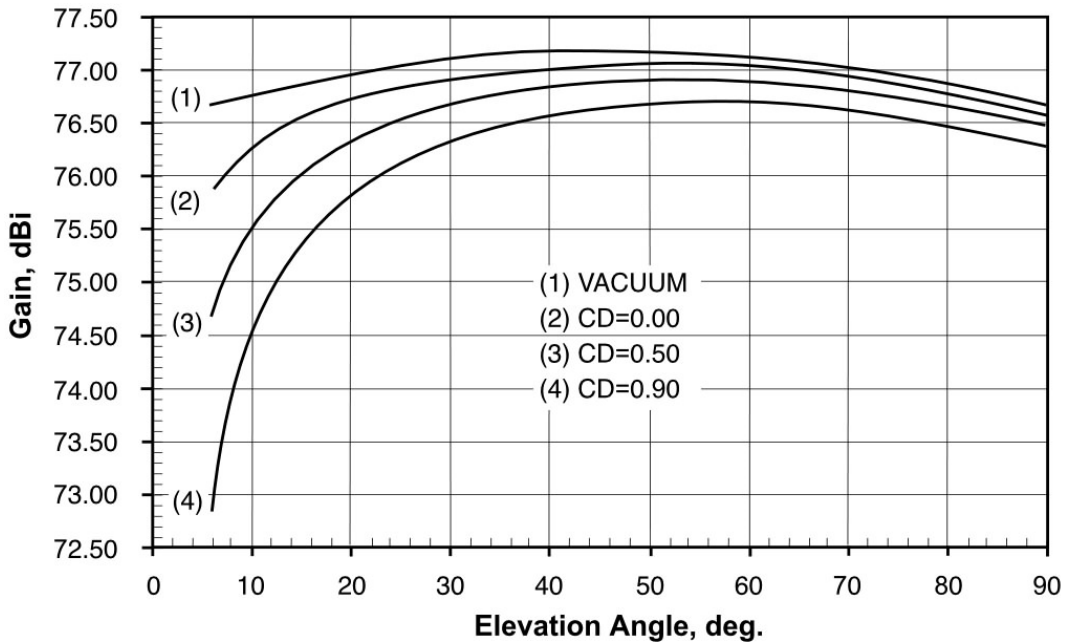

Figure 16. DSS-34 (Canberra) K-Band Receive Gain versus Elevation Angle, K-Only Mode (S/K Dichroic Retracted), 26000 MHz

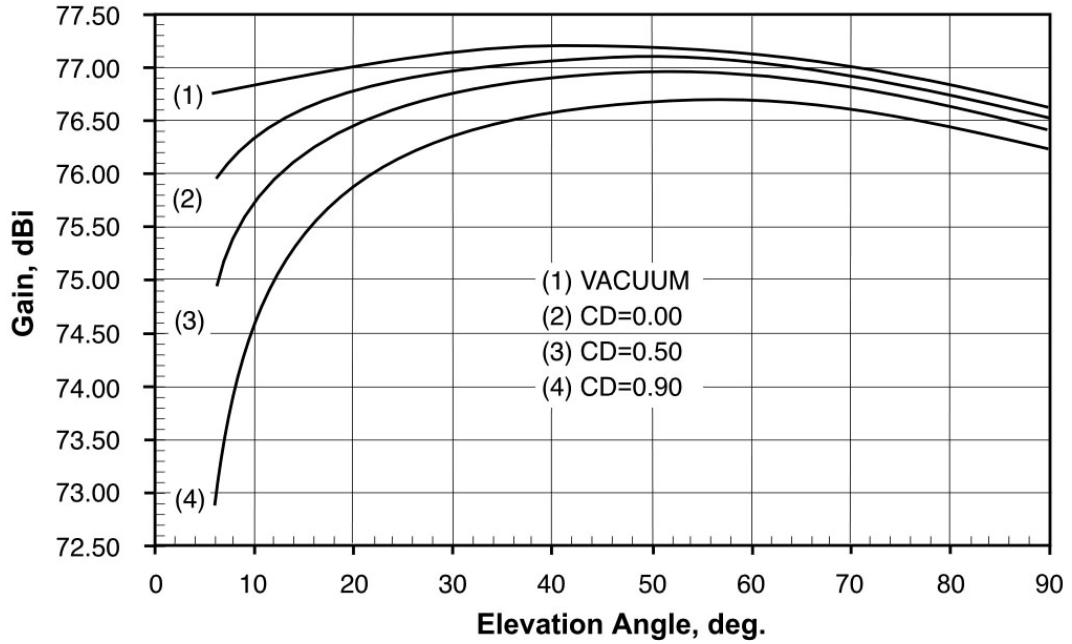

Figure 17. DSS-54 (Madrid) K-Band Receive Gain versus Elevation Angle, K-Only Mode (S/K Dichroic Retracted), 26000 MHz

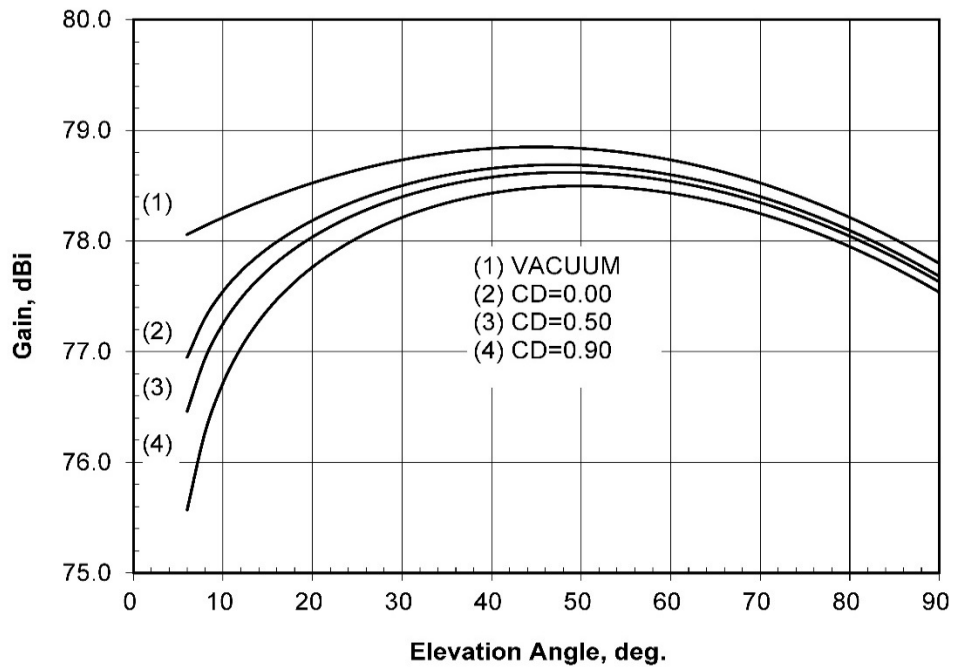

Figure 18. DSS-25 (Goldstone) Ka-Band Receive Gain versus Elevation Angle, X/Ka-Mode (X/Ka Dichroic In-Place), 32000 MHz

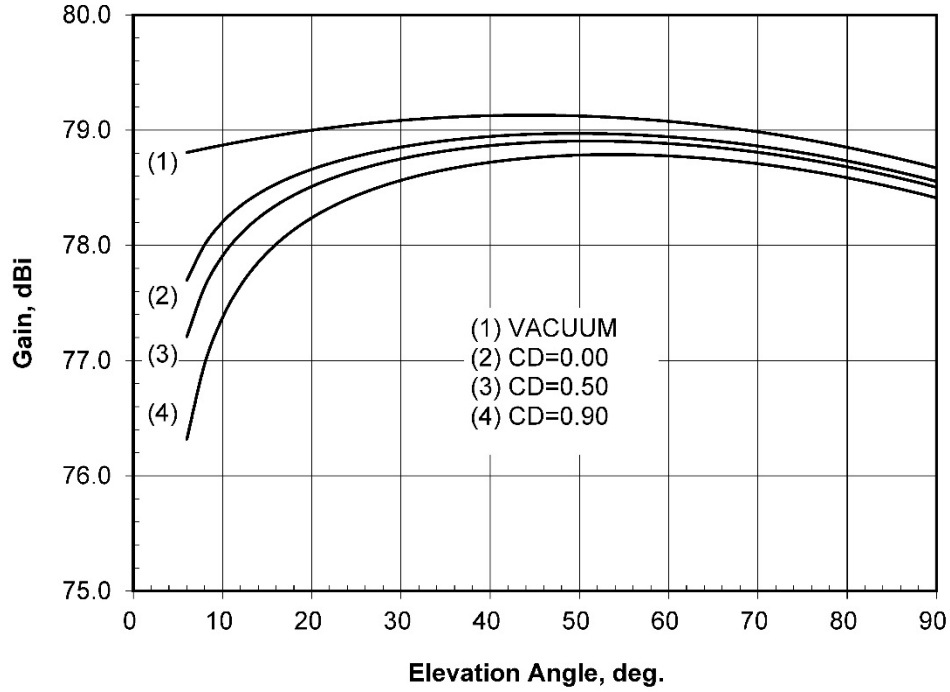

Figure 19. DSS-26 (Goldstone) Ka-Band Receive Gain versus Elevation Angle, X/Ka-Mode, 32000 MHz

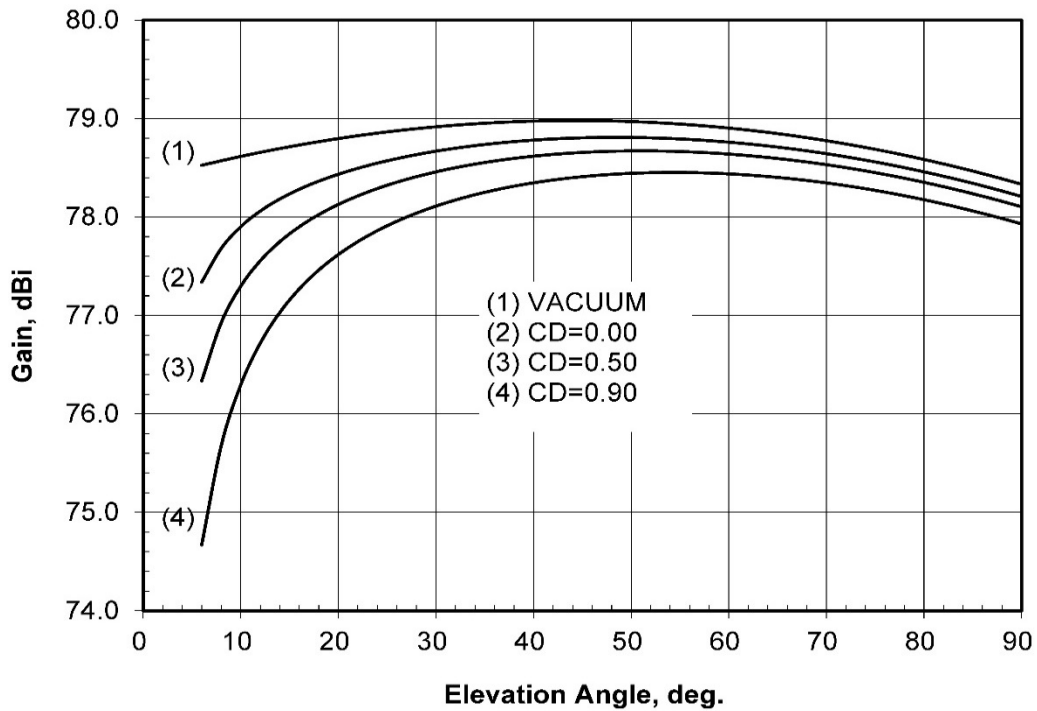

Figure 20. DSS-34 (Canberra) Ka-Band Receive Gain versus Elevation Angle, X/Ka-Mode, 32000 MHz

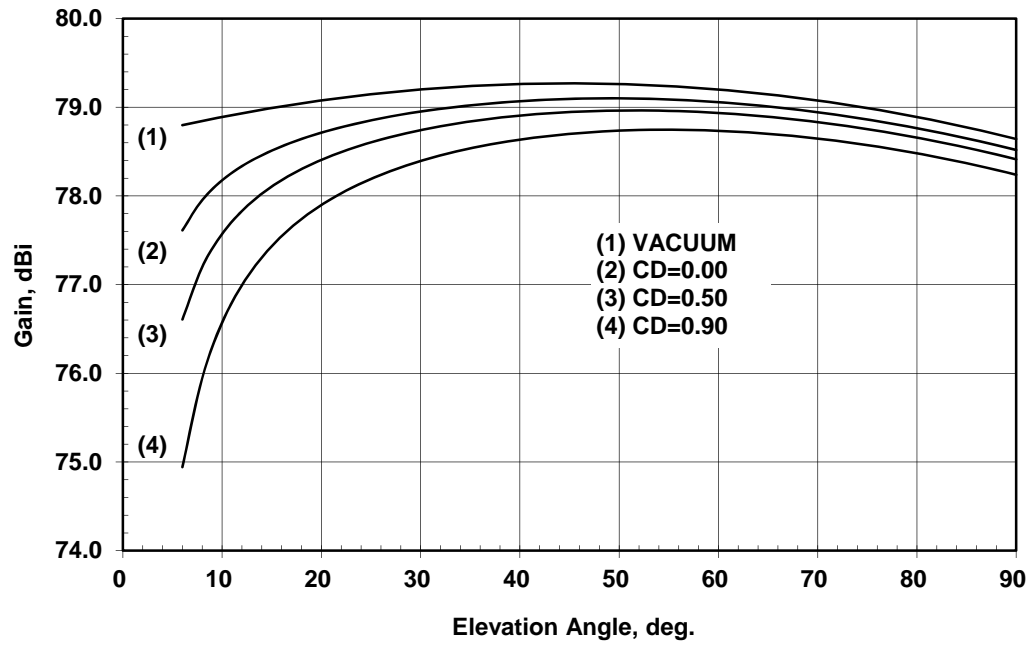

Figure 21. DSS-35 (Canberra) Ka-Band Receive Gain versus Elevation Angle, X/Ka-Mode, 32000 MHz

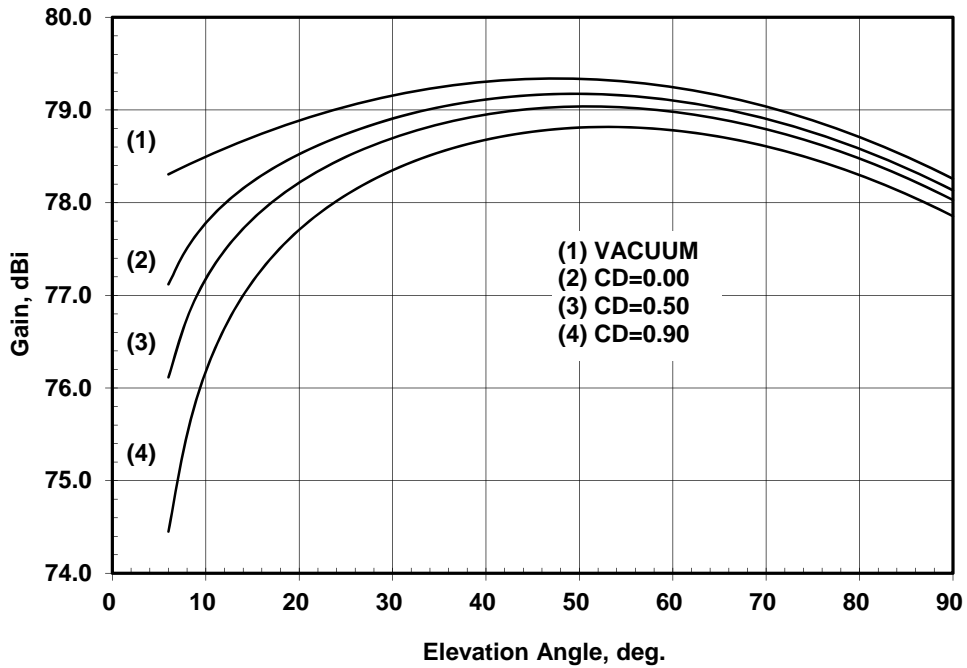

Figure 22. DSS-36 (Canberra) Ka-Band Receive Gain versus Elevation Angle, X/Ka-Mode, 32000 MHz

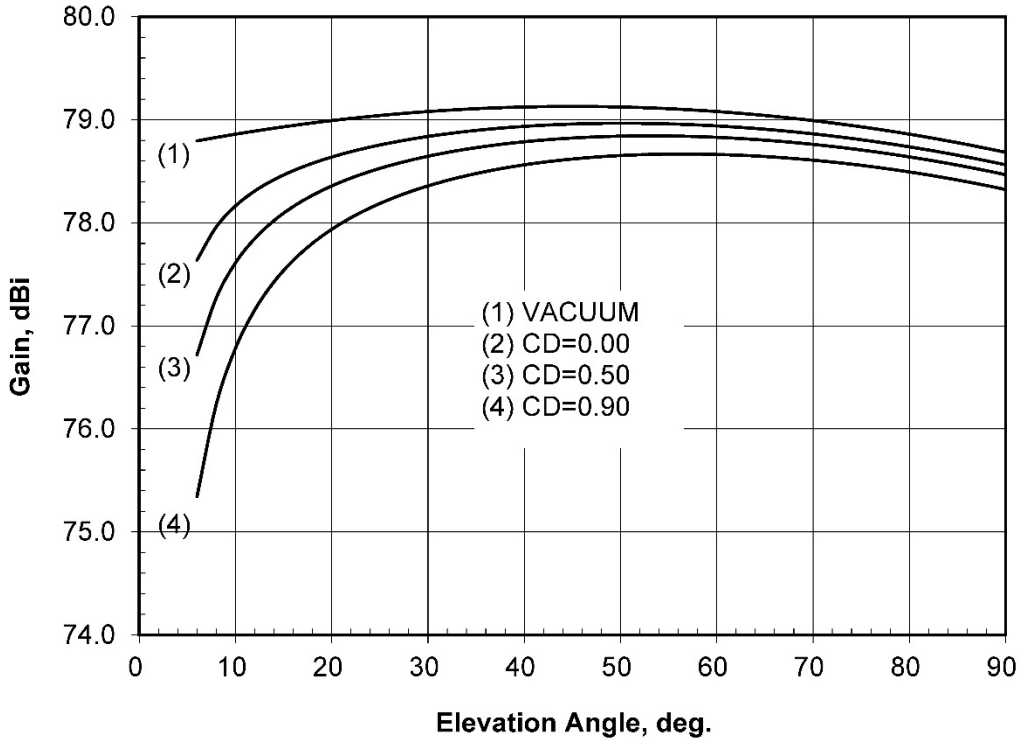

Figure 23. DSS-55 (Madrid) Ka-Band Receive Gain versus Elevation Angle, X/Ka-Mode, 32000 MHz

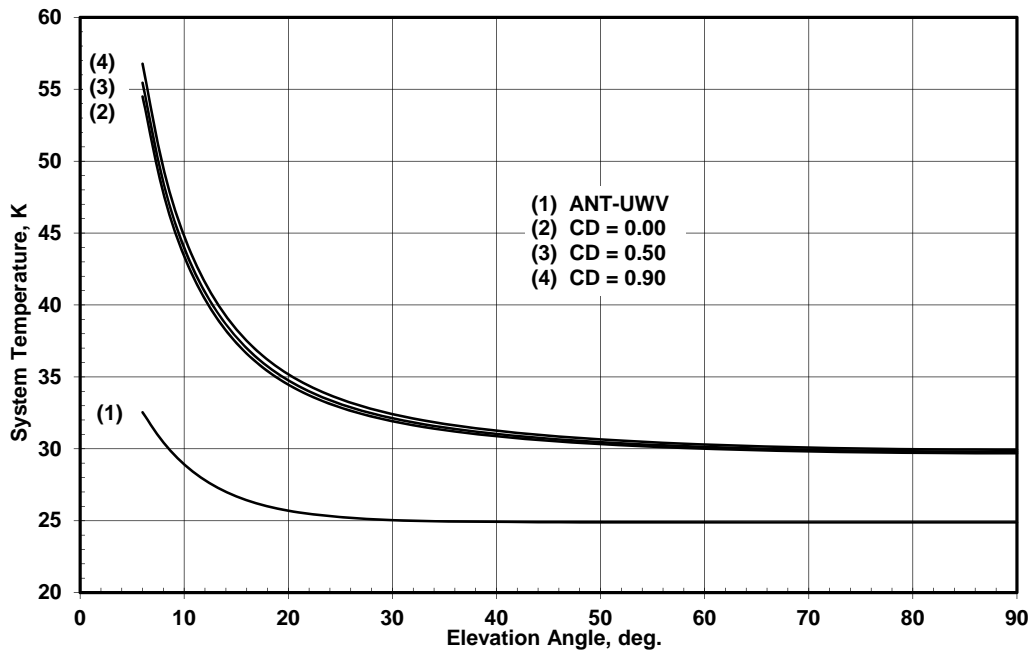

Figure 24. DSS-34 (Goldstone) S-Band System Temperature versus Elevation Angle, S/X-Mode (S/X Dichroic In Place), Non-Diplexed Path, 2295 MHz

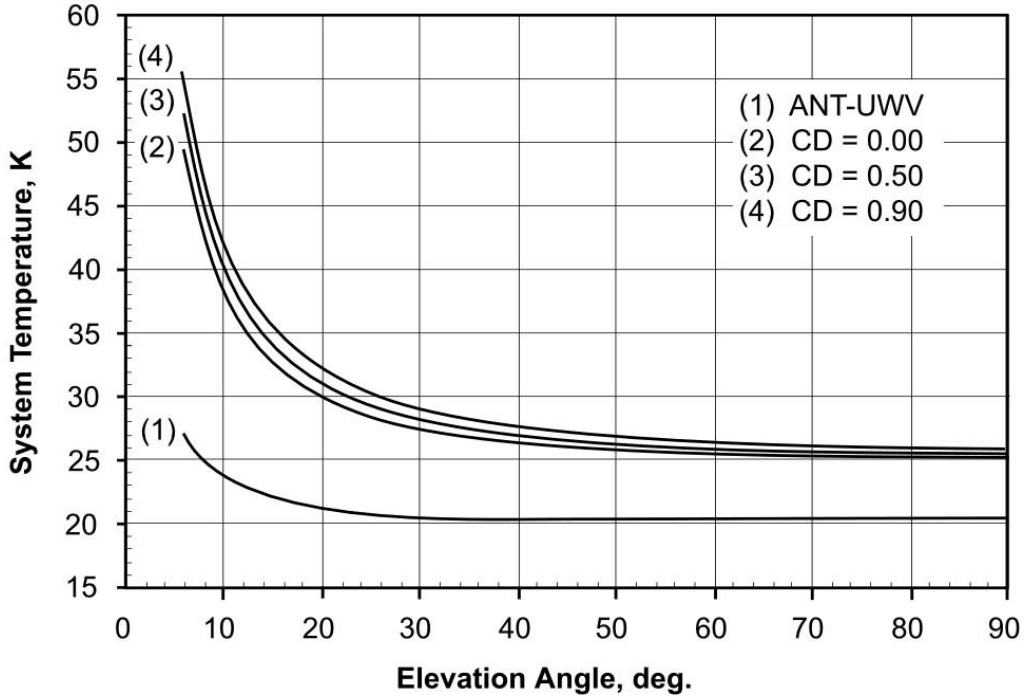

Figure 25. DSS-25 (Goldstone) X-Band System Temperature versus Elevation Angle, X/Ka-mode (X/Ka Dichroic In Place), Non-Diplexed Path, MASER-1, 8420 MHz

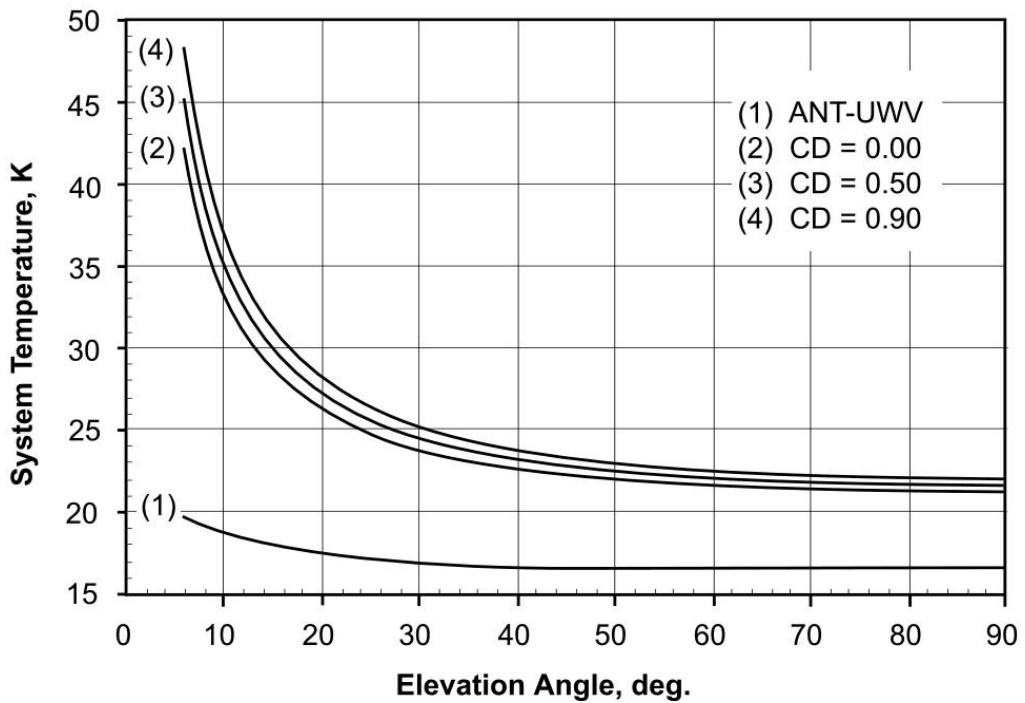

Figure 26. DSS-26 (Goldstone) X-Band RCP System Temperature versus Elevation Angle, X/Ka-Mode, 8420 MHz

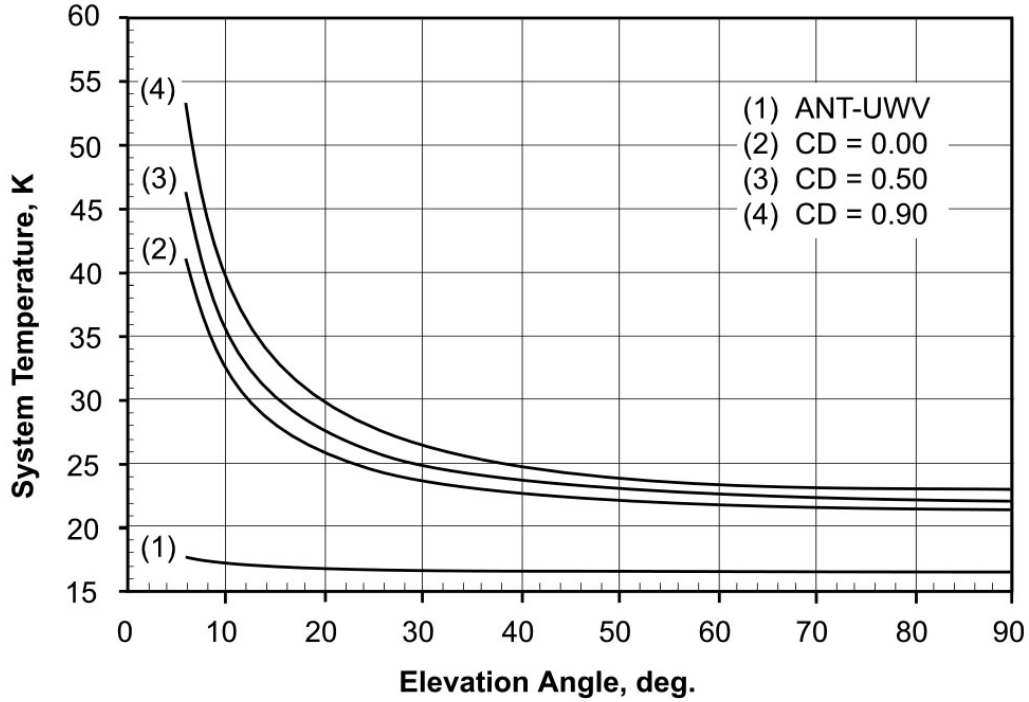

Figure 27. DSS-34 (Canberra) X-Band RCP System Temperature versus Elevation Angle, X/Ka-Mode (S/X Dichroic Retracted), 8420 MHz

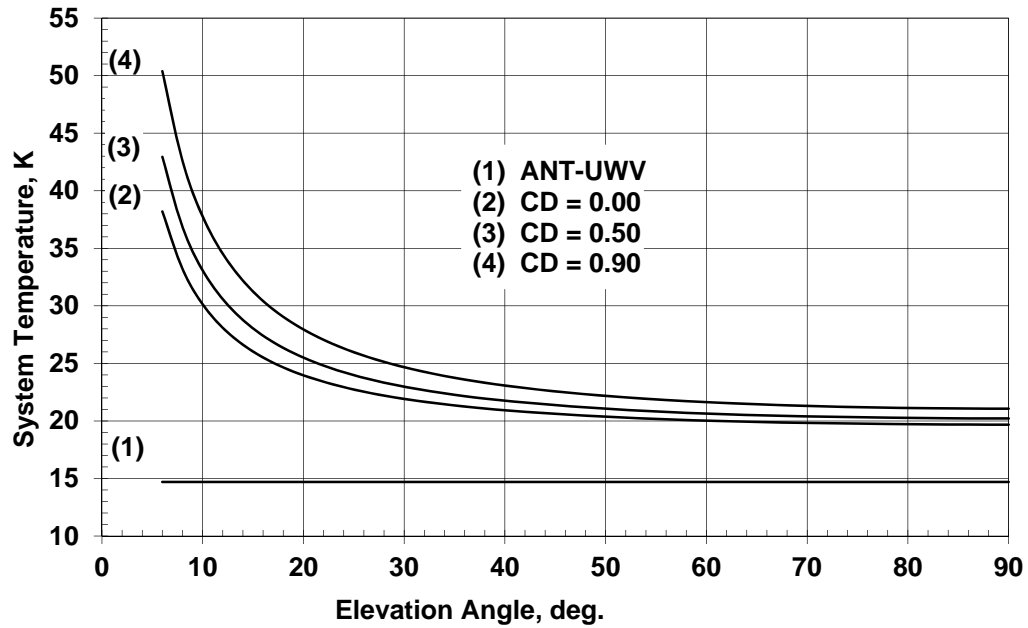

Figure 28. DSS-35 (Canberra) X-Band RCP System Temperature versus Elevation Angle, X/Ka-Mode, 8420 MHz

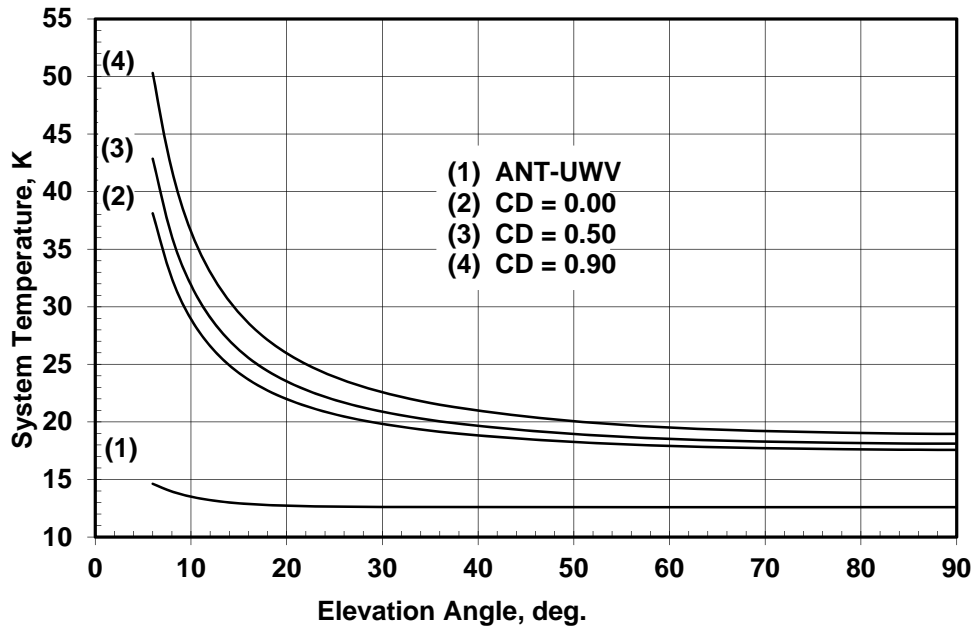

Figure 29. DSS-36 (Canberra) X-Band RCP System Temperature versus Elevation Angle, X/Ka-Mode, 8420 MHz

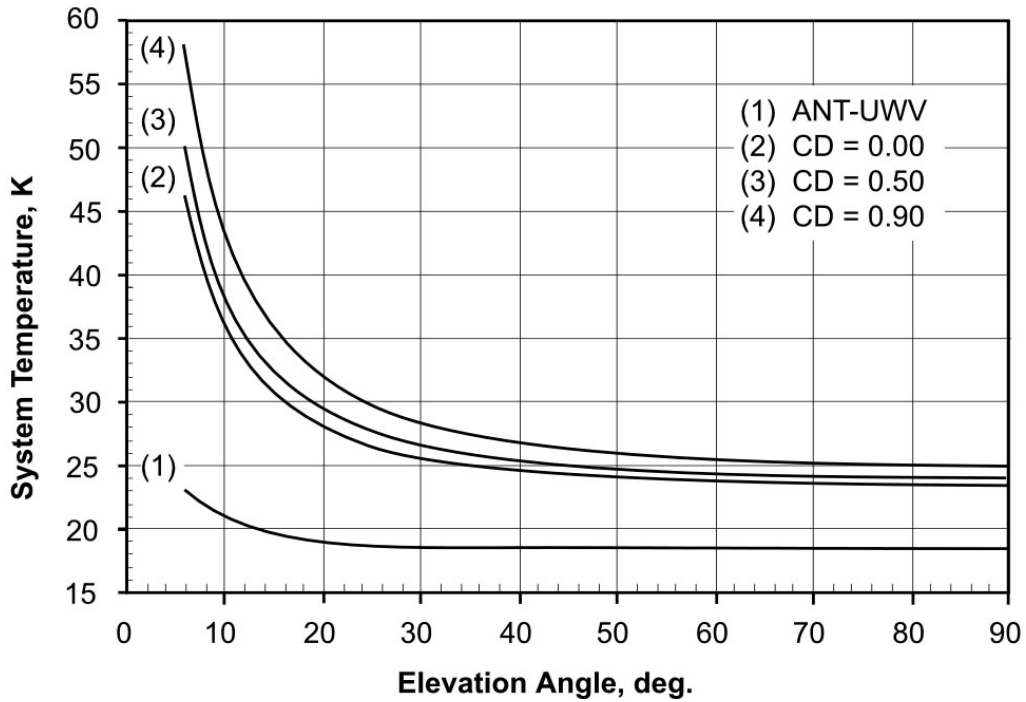

Figure 30. DSS-54 (Madrid) X-Band RCP System Temperature versus Elevation Angle, X/Ka-Mode (S/X Dichroic Retracted), 8420 MHz

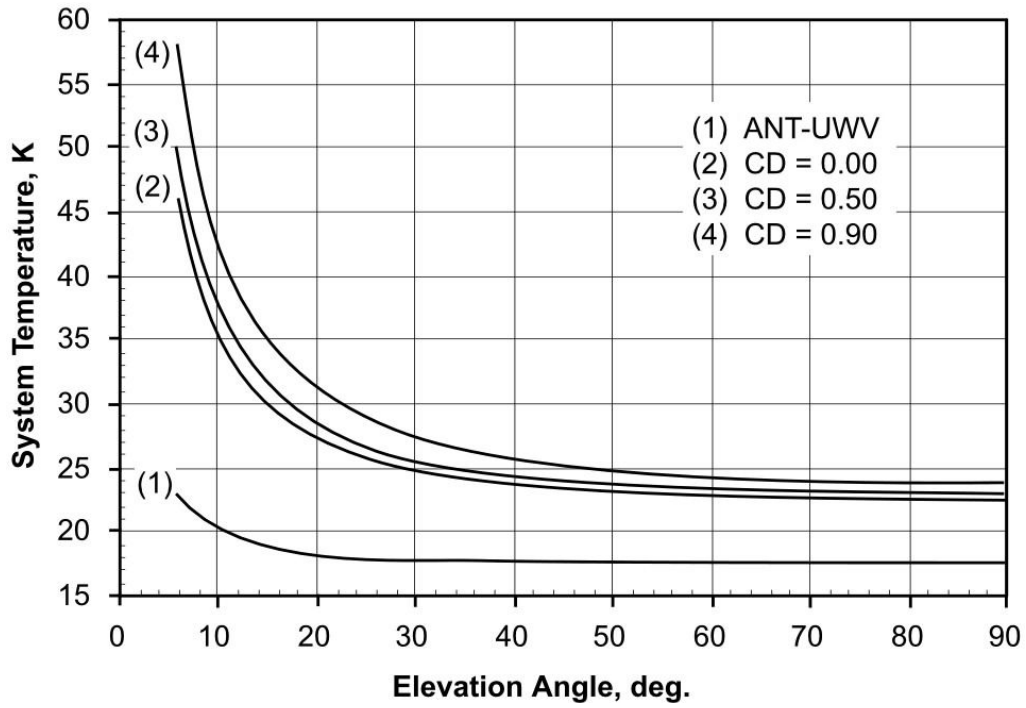

Figure 31. DSS-55 (Madrid) X-Band RCP System Temperature versus Elevation Angle, X/Ka-Mode, 8420 MHz

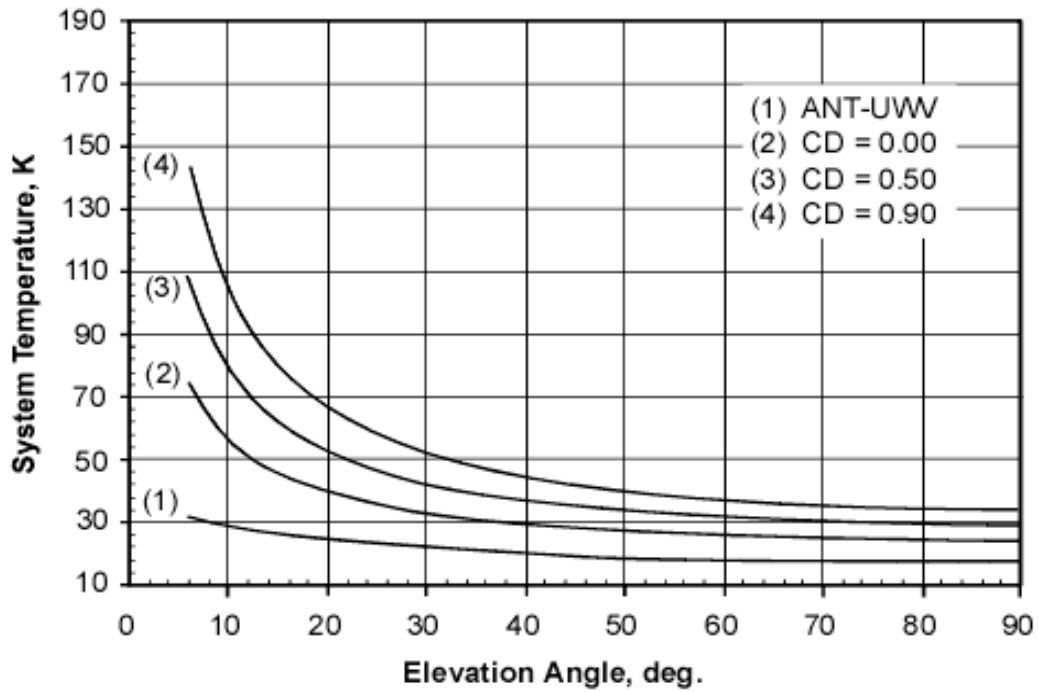

Figure 32. DSS-24 (Goldstone) K-Band RCP System Temperature versus Elevation Angle, K-only Mode (S/K Dichroic Retracted), 26000 MHz

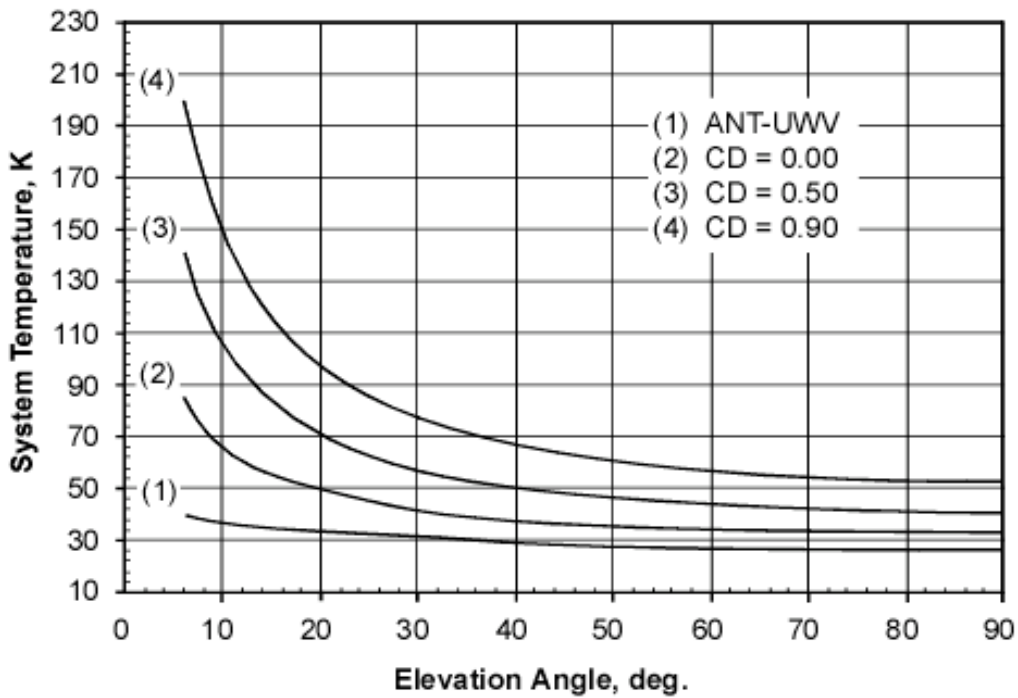

Figure 33. DSS-34 (Canberra) K-Band RCP System Temperature versus Elevation Angle, K-only Mode (S/K Dichroic Retracted), 26000 MHz

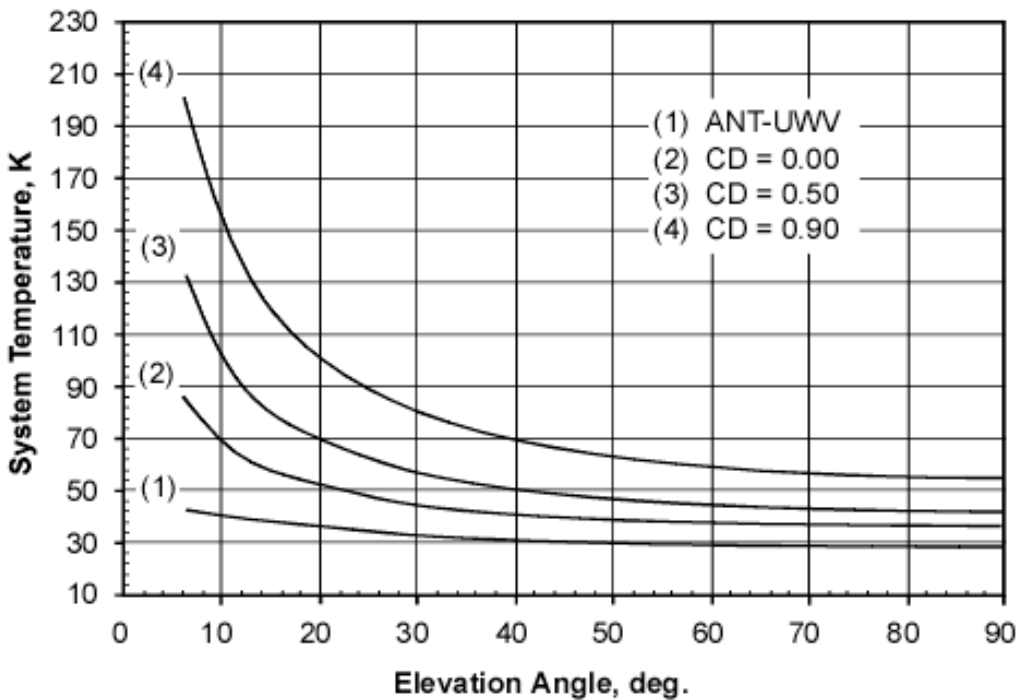

Figure 34. DSS-54 (Madrid) K-Band RCP System Temperature versus Elevation Angle, K-only Mode (S/K Dichroic Retracted), 26000 MHz

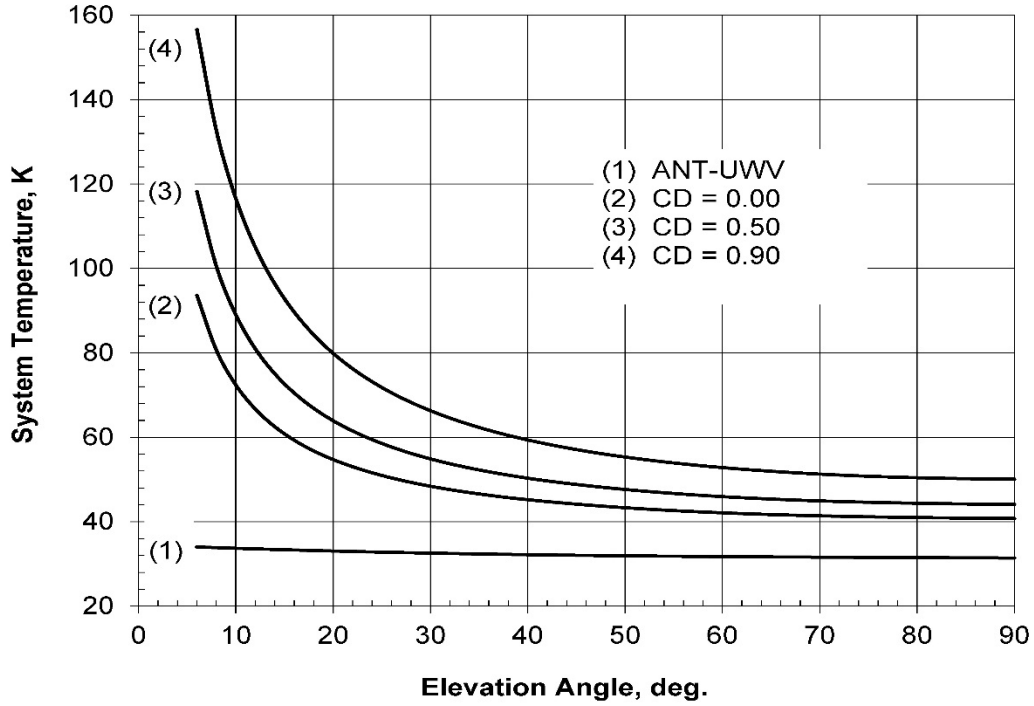

Figure 35. DSS-25 (Goldstone) Ka-Band System Temperature versus Elevation Angle, X/Ka-Mode (X/Ka Dichroic in Place), 32000 MHz

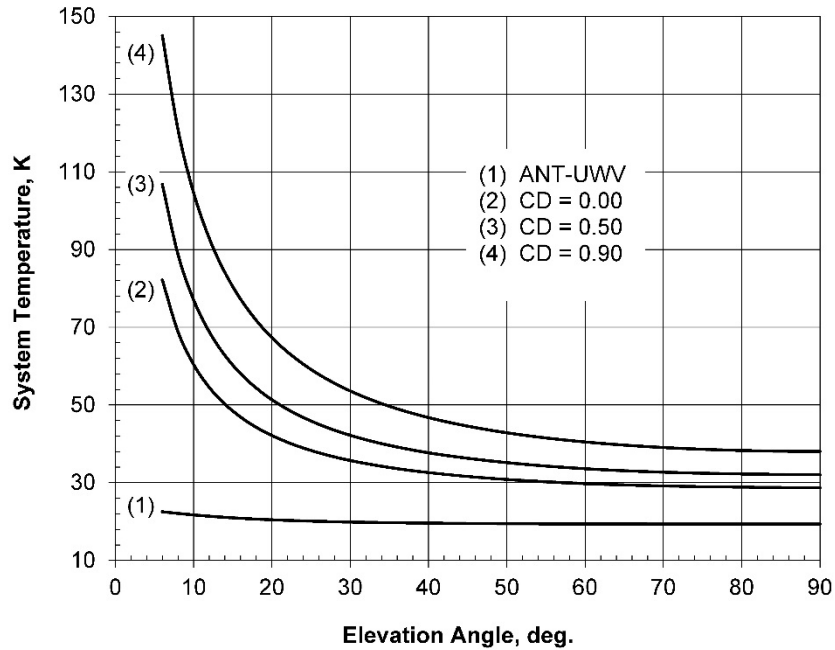

Figure 36. DSS-26 (Goldstone) Ka-Band RCP System Temperature versus Elevation Angle, X/Ka-Mode, 32000 MHz

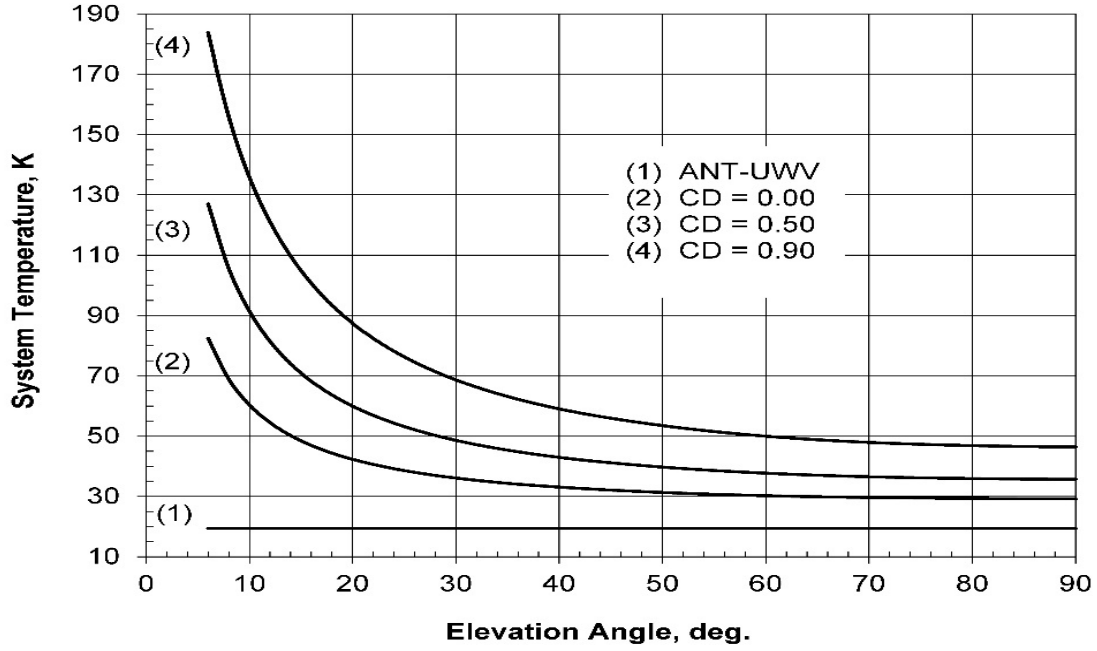

Figure 37. DSS-34 (Canberra) Ka-Band RCP System Temperature versus Elevation Angle, X/Ka-Mode, 32000 MHz

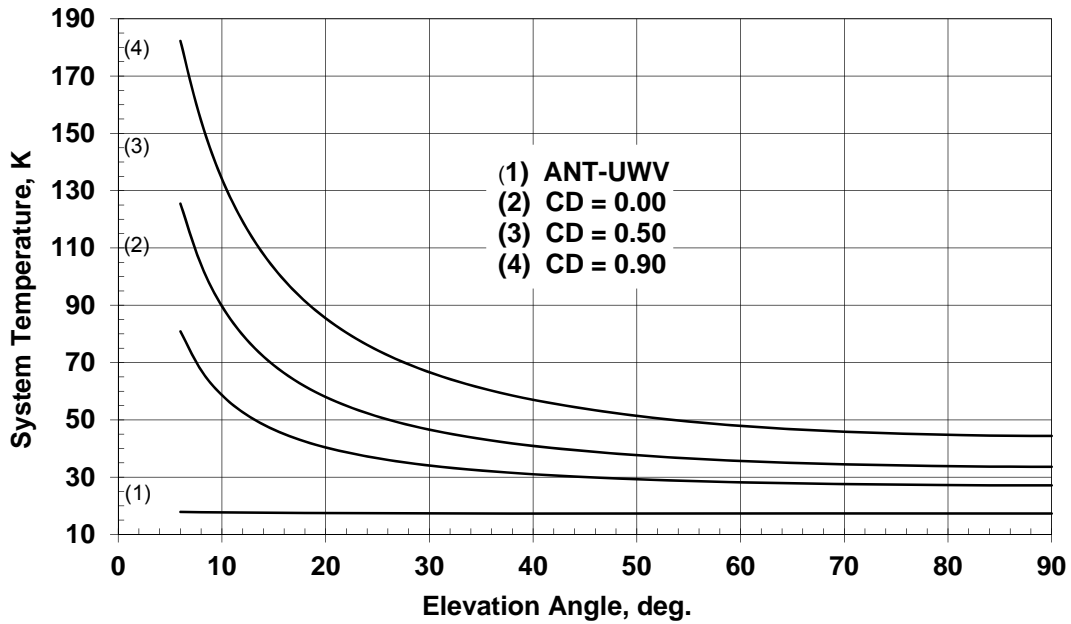

Figure 38. DSS-35 (Canberra) Ka-Band RCP System Temperature versus Elevation Angle, X/Ka-Mode, 32000 MHz

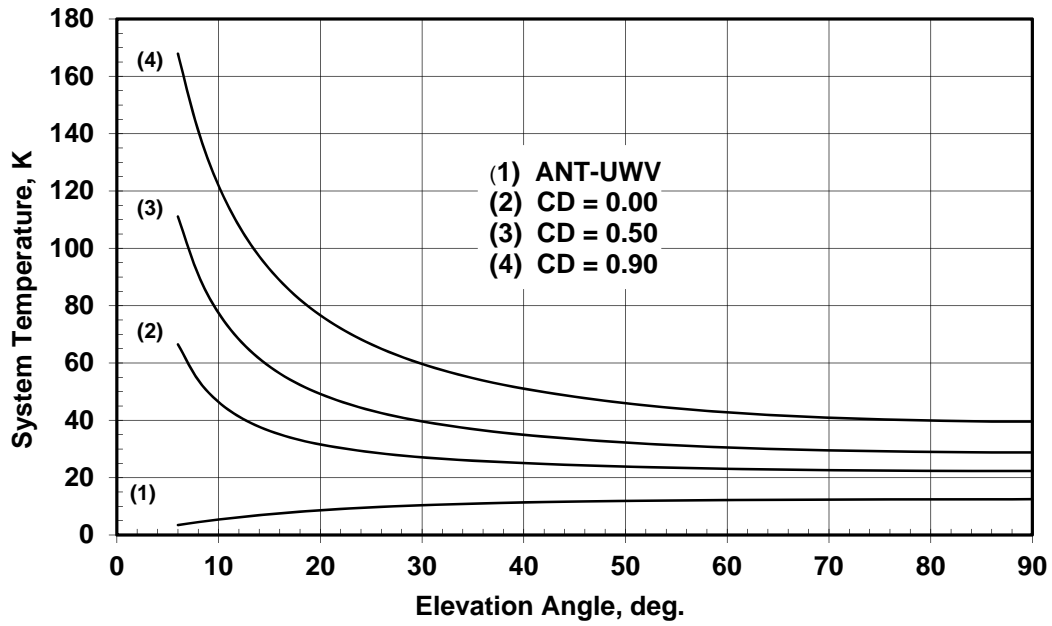

Figure 39. DSS-36 (Canberra) Ka-Band RCP System Temperature versus Elevation Angle, X/Ka-Mode, 32000 MHz

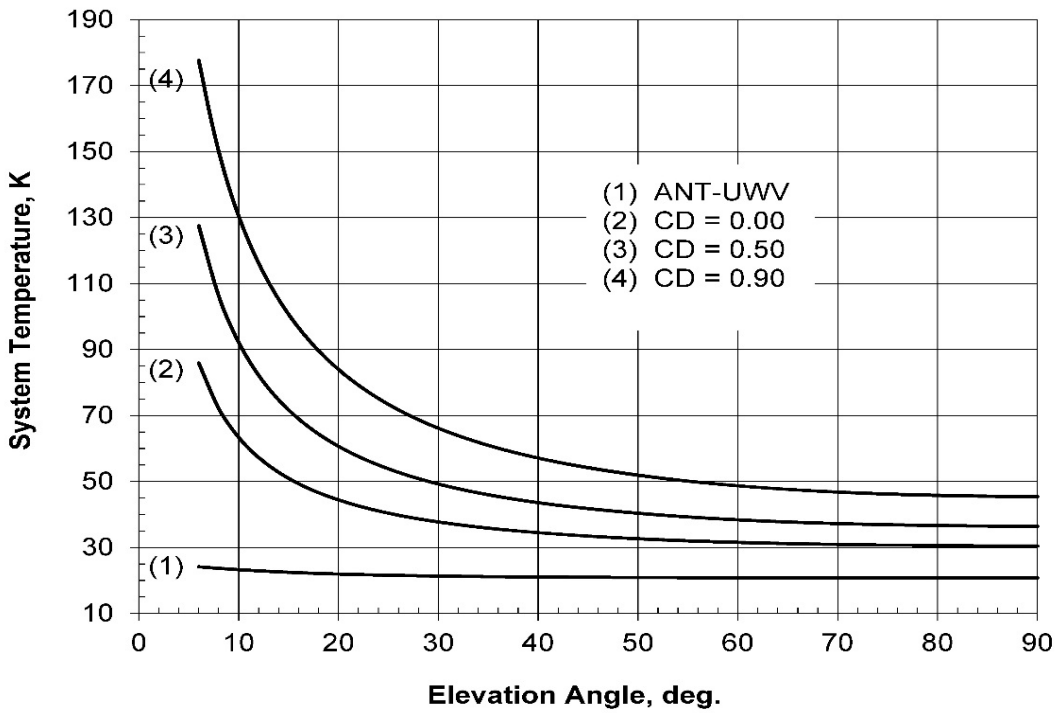

Figure 40. DSS-55 (Madrid) Ka-Band RCP System Temperature versus Elevation Angle, X/Ka-Mode, 32000 MHz

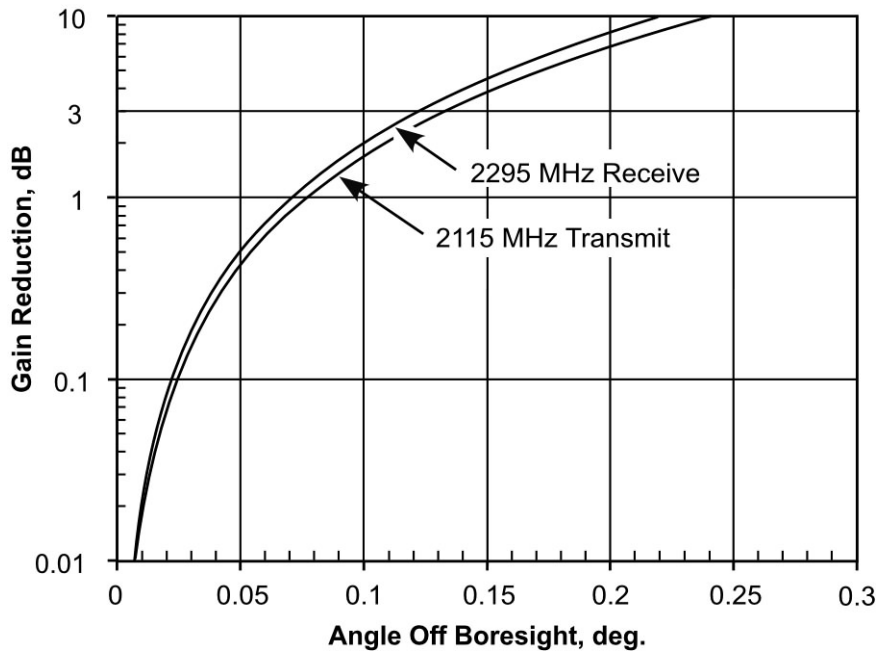

Figure 41. S-Band Gain Reduction versus Angle off Boresight

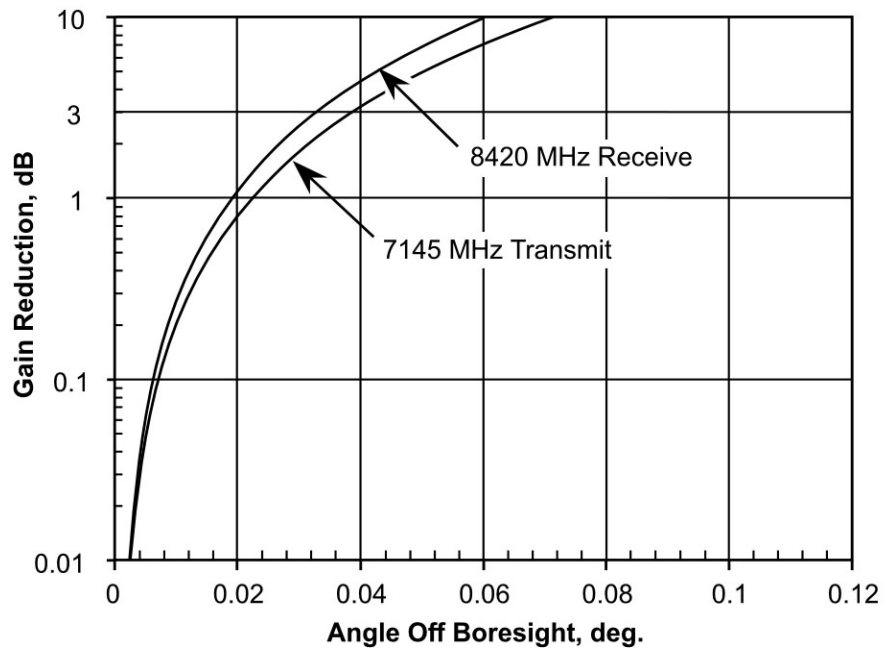

Figure 42. X-Band Gain Reduction versus Angle off Boresight

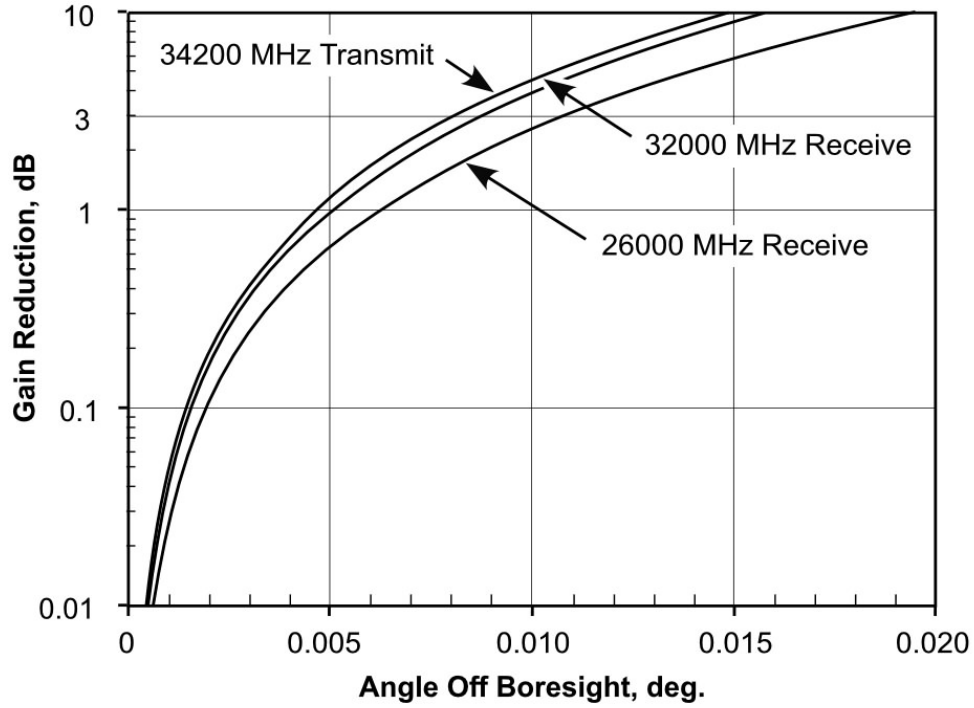

Figure 43. K- and Ka-Band Gain Reduction versus Angle off Boresight

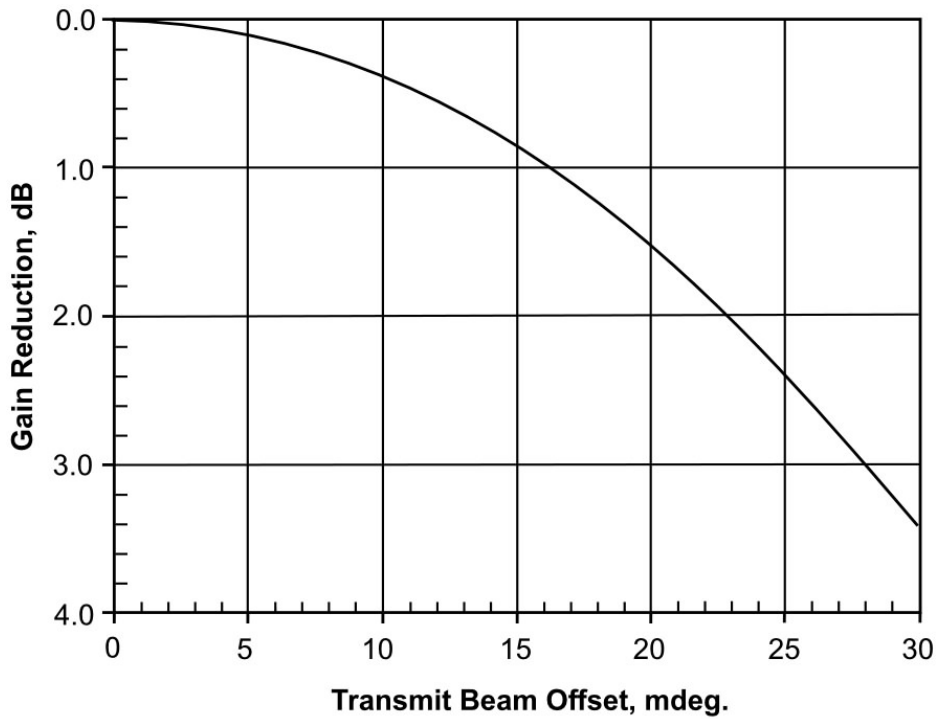

Figure 44. Ka-Band Transmit Gain Reduction Due to Aberration Correction

Appendix A Equations for Modeling

A.1 Equations for Gain Versus Elevation Angle

The following equation can be used to generate S-, X-, K-, and Ka-band transmit and receive gain versus elevation angle curves. Examples of these curves for selected stations and configurations are shown in Figures 7–23. See paragraph 2.1.1.1 for frequency effect modeling and module 105 for atmospheric attenuation at weather conditions other than 0%, 50%, and 90% cumulative distribution.

$$G(\theta) = G_0 - G_1(\theta - \gamma)^2 - \frac{A_{zen}}{\sin \theta}, \text{ dBi} \quad (\text{A-1})$$

where

- θ = antenna elevation angle (deg.) $6 \leq \theta \leq 90$
- G_0, G_1, γ = parameters from Table A-1 through Table A-4
- A_{zen} = zenith atmospheric attenuation, dB, from Table A-5 or from Tables 10 through 18 in module 105

A.2 Equations for System Temperature Versus Elevation Angle

The following equation can be used to generate S-, X-, and Ka-band system temperature versus elevation angle curves. Examples of these curves are shown in Figures 24-40. See module 105 for atmospheric attenuation at weather conditions other than 0%, 50%, and 90% cumulative distribution.

System operating noise temperature:

$$T_{op}(\theta) = T_{AMW} + T_{sky} \quad (\text{A2})$$

Antenna-Microwave noise contribution:

$$T_{AMW} = T_1 + T_2 e^{-a\theta} \quad (\text{A3})$$

Sky noise contribution:

$$T_{sky} = T_{atm}(\theta) + T'_{CMB}(\theta) \quad (\text{A4})$$

Atmospheric attenuation:

$$A(\theta) = \frac{A_{zen}}{\sin(\theta)}, \text{ dB} \quad (\text{A5})$$

Atmospheric loss factor:

$$L(\theta) = 10^{\frac{A(\theta)}{10}}, \text{ dimensionless, } > 1.0 \quad (\text{A6})$$

Atmosphere mean physical temperature:

$$T_p = 255 + 25 \times CD, \text{ K} \quad (\text{A7})$$

Atmospheric noise contribution:

$$T_{atm}(\theta) = T_p \left[1 - \frac{1}{L(\theta)} \right], \text{ K} \quad (\text{A8})$$

Effective cosmic background noise:

$$T'_{CMB}(\theta) = \frac{T_{CMB}}{L(\theta)}, \text{ K} \quad (\text{A9})$$

where

- θ = antenna elevation angle (deg.), $6 \leq \theta \leq 90$
- T_1, T_2, a = antenna-microwave noise temperature parameters from Tables A-1 through A-4
- A_{zen} = zenith atmospheric attenuation, dB, from Table A-5 or from Tables 10–18 in Module 105 as a function of frequency, station, and cumulative distribution (CD)
- CD = cumulative distribution, $0 \leq CD \leq 0.99$, used to select A_{ZEN} from Table A-5 or from Tables 10–18 in Module 105
- T_{CMB} = 2.725 K, cosmic microwave background noise temperature

A.3 Equation for Gain Reduction Versus Pointing Error

The following equation can be used to generate gain reduction versus pointing error curves examples of which are depicted in Figures 41–43.

$$\Delta G(\theta) = 10 \log \left(e^{\frac{2.773\theta^2}{HPBW^2}} \right), \text{ dB} \quad (\text{A-3})$$

where

$$\begin{aligned} \theta &= \text{pointing error, deg} \\ HPBW &= \text{half-power beamwidth (from Tables 2–7)} \end{aligned}$$

A.4 Equation for Transmit Aberration Gain Reduction

The following equation can be used to generate the Ka-band transmit gain reduction curve depicted in Figure 44.

$$\Delta G(\phi) = -0.0038\phi^2, \text{ dB} \quad (\text{A-4})$$

where

$$\phi = \text{transmit beam offset, mdeg}$$

Table A-1. S-Band Vacuum Gain and Antenna-Microwave Noise Temperature Parameters, Referenced to Feedhorn Aperture

Station and Configuration	Vacuum Gain Parameters				Antenna-Microwave Noise Temperature Parameters			Figures
	G ₀ Transmit	G ₀ Receive	G ₁	γ	T ₁	T ₂	a	
DSS-24 (Goldstone)								
S/X or S/K, HEMT-1, RCP or LCP, Non-Diplexed	-	56.87	0.000032	90.0	26.04	5.2	0.05	
S/X or S/K, HEMT-1, RCP or LCP, Diplexed	56.20	56.87	0.000032	90.0	33.41	5.6	0.05	
DSS-34 (Canberra)								
S/X or S/K, HEMT-1, RCP or LCP, Non-Diplexed	-	56.83	0.000042	43.19	24.88	20.0	0.16	Figure 7 Figure 24
S/X or S/K, HEMT-1, RCP or LCP, Diplexed	56.16	56.83	0.000042	43.19	34.46	20.0	0.16	
DSS-36 (Canberra)								
S/X or S/K, HEMT-1, RCP or LCP, Non-Diplexed	-	56.63	0.000042	45.00	21.57	28.0	0.20	
S/X or S/K, HEMT-1, RCP or LCP, Diplexed, Near-Earth Band	55.79	56.63	0.000042	45.00	30.43	28.0	0.20	
DSS-54 (Madrid)								
S/X or S/K, HEMT-1, RCP or LCP, Non-Diplexed	-	56.83	0.000042	45.00	25.72	12.0	0.08	
S/X or S/K, HEMT-1, RCP or LCP, Diplexed	56.16	56.83	0.000042	45.00	35.34	12.0	0.08	

NOTE:

Go values are nominal at the frequency specified in Table 2 and Table 5. Other parameters apply to all frequencies within the same band. The nominal S-band uplink frequency at DSS-24, -34, -36, and -54 is 2115 MHz. The nominal S-band downlink frequency at DSS-24, -34, -36, and -54 is 2295 MHz.

Table A-2. X-Band Vacuum Gain and Antenna-Microwave Noise Temperature Parameters, Referenced to Feedhorn Aperture

Station and Configuration	Vacuum Gain Parameters				Antenna-Microwave Noise Temperature Parameters			Figures
	G ₀ Transmit	G ₀ Receive	G ₁	γ	T ₁	T ₂	a	
DSS-24 (Goldstone)								
X-Only, MASER-1, RCP or LCP, Non-Diplexed	-	68.24	0.000027	51.50	21.28	1.5	0.11	
X-Only, MASER-1, RCP or LCP, Diplexed	67.06	68.24	0.000027	51.50	30.39	2.9	0.11	
S/X, MASER-1, RCP or LCP, Non-Diplexed	-	68.19	0.000027	51.50	22.72	1.5	0.11	
S/X, MASER-1, RCP or LCP, Diplexed	-	68.19	0.000027	51.50	31.89	2.9	0.11	
DSS-25 (Goldstone)								
X/Ka, MASER-1, RCP or LCP, Non-Diplexed	-	68.50	0.000028	47.50	20.20	16.4	0.15	Figure 8 Figure 25
X/Ka, HEMT-1, RCP or LCP, Non-Diplexed	-	68.50	0.000028	47.50	35.06	17.4	0.15	
X/Ka, MASER-1, RCP or LCP, Diplexed	67.32	68.50	0.000028	47.50	29.26	19.0	0.15	
X/Ka, HEMT-1, RCP or LCP, Diplexed	67.39	68.50	0.000028	47.50	44.88	20.1	0.15	
DSS-26 (Goldstone)								
X/Ka, HEMT-1, RCP, Diplexed	66.93	68.29	0.000059	42.46	16.29	5.2	0.08	Figure 9 Figure 26
X/Ka, HEMT-2, LCP, Diplexed	66.93	68.29	0.000059	42.46	15.43	5.2	0.08	
DSS-34 (Canberra)								
X/Ka, HEMT-1, RCP, Diplexed	66.97	68.33	0.000045	48.64	16.28	5.0	0.15	Figure 10 Figure 27
X/Ka, HEMT-2, LCP, Diplexed	66.97	68.33	0.000045	48.64	16.71	5.0	0.15	
S/X, HEMT-1, RCP, Diplexed	-	68.28	0.000045	48.64	17.99	5.0	0.15	
S/X, HEMT-2, LCP, Diplexed	-	68.28	0.000045	48.64	18.43	5.0	0.15	
DSS-35 (Canberra)								
X/Ka, HEMT-1, RCP, Diplexed	66.99	68.35	0.000045	45.00	14.7	0.0	0.00	Figure 11 Figure 28
X/Ka, HEMT-2, LCP, Diplexed	66.99	68.35	0.000045	45.00	15.0	0.0	0.00	

Table A-2. X-Band Vacuum Gain and Antenna-Microwave Noise Temperature Parameters, Referenced to Feedhorn Aperture (continued)

Station and Configuration	Vacuum Gain Parameters				Antenna-Microwave Noise Temperature Parameters			Figures
	G ₀ Transmit	G ₀ Receive	G ₁	γ	T ₁	T ₂	a	
DSS-36 (Canberra)								
X/Ka, HEMT-1, RCP, Diplexed	66.98	68.34	0.000045	45.00	12.59	15.0	0.20	Figure 12 Figure 29
X/Ka, HEMT-2, LCP, Diplexed	66.98	68.34	0.000045	45.00	13.95	12.0	0.20	
S/X, HEMT-1, RCP, Diplexed	-	68.29	0.000045	45.00	14.31	15.0	0.20	
S/X, HEMT-2, LCP, Diplexed	-	68.29	0.000045	45.00	15.67	12.0	0.20	
DSS-54 (Madrid)								
X/Ka, HEMT-1, RCP, Diplexed	67.01	68.37	0.000058	45.25	18.31	11.0	0.15	Figure 13 Figure 30
X/Ka, HEMT-2, LCP, Diplexed	67.01	68.37	0.000058	45.25	18.31	11.0	0.15	
S/X, HEMT-1, RCP, Diplexed	-	68.32	0.000058	45.25	20.03	11.0	0.15	
S/X, HEMT-2, LCP, Diplexed	-	68.32	0.000058	45.25	20.03	11.0	0.15	
DSS-55 (Madrid)								
X/Ka, HEMT-1, RCP, Diplexed	66.98	68.34	0.000035	43.55	17.42	13.2	0.15	Figure 14 Figure 31
X/Ka, HEMT-2, LCP, Diplexed	66.98	68.34	0.000035	43.55	17.82	13.2	0.15	

NOTES:

G₀ values are nominal at the frequency specified in Table 3, Table 6, and Table 7. Other parameters apply to all frequencies within the same band. . The nominal X-band uplink frequency is 7145 MHz. The nominal X-band downlink frequency is 8420 MHz.

For low-gain mode add +20 K to T₁ values (X-band).

Table A-3. K-Band Vacuum Gain and Antenna-Microwave Noise Temperature Parameters, Referenced to Feedhorn Aperture

Station and Configuration	Vacuum Gain Parameters			Antenna-Microwave Noise Temperature Parameters			Figures
	G_0 Receive	G_1	\square	T_1	T_2	a	
DSS-24 (Goldstone)							
K-only, HEMT-1, RCP, 25.5 GHz, Non-Diplexed	77.03	0.00029	45.0	19.6	19.6	0.05	
K-only, HEMT-2, LCP, 25.5 GHz, Non-Diplexed	77.03	0.00029	45.0	27.1	19.6	0.05	
S/K, HEMT-1, RCP, 25.5 GHz, Non-Diplexed	76.99	0.00029	45.0	30.3	20.4	0.065	
S/K, HEMT-2, LCP, 25.5 GHz, Non-Diplexed	76.99	0.00029	45.0	37.8	20.4	0.065	
K-only, HEMT-1, RCP, 26.0 GHz, Non-Diplexed	77.20	0.00029	45.0	17.5	19.6	0.05	Figure 15 Figure 32
K-only, HEMT-2, LCP, 26.0 GHz, Non-Diplexed	77.20	0.00029	45.0	23.5	19.6	0.05	
S/K, HEMT-1, RCP, 26.0 GHz, Non-Diplexed	77.16	0.00029	45.0	23.5	20.4	0.065	
S/K, HEMT-2, LCP, 26.0 GHz, Non-Diplexed	77.16	0.00029	45.0	29.5	20.4	0.065	
K-only, HEMT-1, RCP, 27.0 GHz, Non-Diplexed	77.53	0.00029	45.0	20.8	19.6	0.05	
K-only, HEMT-2, LCP, 27.0 GHz, Non-Diplexed	77.53	0.00029	45.0	25.4	19.6	0.05	
S/K, HEMT-1, RCP, 27.0 GHz, Non-Diplexed	77.49	0.00029	45.0	30.5	20.4	0.065	
S/K, HEMT-2, LCP, 27.0 GHz, Non-Diplexed	77.49	0.00029	45.0	35.1	20.4	0.065	

Table A-3. K-Band Vacuum Gain and Antenna-Microwave Noise Temperature Parameters, Referenced to Feedhorn Aperture (continued)

Station and Configuration	Vacuum Gain Parameters			Antenna-Microwave Noise Temperature Parameters			Figures
	G_0 Receive	G_1	γ	T_1	T_2	a	
DSS-34 (Canberra)							
K-only, HEMT-1, RCP, 25.5 GHz, Non-Diplexed	77.02	0.00029	48.0	24.9	19.6	0.05	
K-only, HEMT-2, LCP, 25.5 GHz, Non-Diplexed	77.02	0.00029	48.0	26.3	19.6	0.05	
S/K, HEMT-1, RCP, 25.5 GHz, Non-Diplexed	76.98	0.00029	48.0	35.6	20.4	0.065	
S/K, HEMT-2, LCP, 25.5 GHz, Non-Diplexed	76.98	0.00029	48.0	37.0	20.4	0.065	
K-only, HEMT-1, RCP, 26.0 GHz, Non-Diplexed	77.19	0.00029	48.0	25.3	19.6	0.05	Figure 16 Figure 33
K-only, HEMT-2, LCP, 26.0 GHz, Non-Diplexed	77.19	0.00029	48.0	25.4	19.6	0.05	
S/K, HEMT-1, RCP, 26.0 GHz, Non-Diplexed	77.15	0.00029	48.0	31.3	20.4	0.065	
S/K, HEMT-2, LCP, 26.0 GHz, Non-Diplexed	77.15	0.00029	48.0	31.4	20.4	0.065	
K-only, HEMT-1, RCP, 27.0 GHz, Non-Diplexed	77.52	0.00029	48.0	23.7	19.6	0.05	
K-only, HEMT-2, LCP, 27.0 GHz, Non-Diplexed	77.52	0.00029	48.0	24.5	19.6	0.05	
S/K, HEMT-1, RCP, 27.0 GHz, Non-Diplexed	77.48	0.00029	48.0	33.4	20.4	0.065	
S/K, HEMT-2, LCP, 27.0 GHz, Non-Diplexed	77.48	0.00029	48.0	34.2	20.4	0.065	

Table A-3. K-Band Vacuum Gain and Antenna-Microwave Noise Temperature Parameters, Referenced to Feedhorn Aperture (continued)

Station and Configuration	Vacuum Gain Parameters			Antenna-Microwave Noise Temperature Parameters			Figures
	G_0 Receive	G_1	γ	T_1	T_2	a	
DSS-54 (Madrid)							
K-only, HEMT-1, RCP, 25.5 GHz, Non-Diplexed	77.02	0.00029	45.0	28.2	19.6	0.05	
K-only, HEMT-2, LCP, 25.5 GHz, Non-Diplexed	77.02	0.00029	45.0	30.7	19.6	0.05	
S/K, HEMT-1, RCP, 25.5 GHz, Non-Diplexed	76.98	0.00029	45.0	38.9	20.4	0.065	
S/K, HEMT-2, LCP, 25.5 GHz, Non-Diplexed	76.98	0.00029	45.0	41.4	20.4	0.065	
K-only, HEMT-1, RCP, 26.0 GHz, Non-Diplexed	77.19	0.00029	45.0	28.1	19.6	0.05	Figure 17 Figure 34
K-only, HEMT-2, LCP, 26.0 GHz, Non-Diplexed	77.19	0.00029	45.0	29.0	19.6	0.05	
S/K, HEMT-1, RCP, 26.0 GHz, Non-Diplexed	77.15	0.00029	45.0	34.1	20.4	0.065	
S/K, HEMT-2, LCP, 26.0 GHz, Non-Diplexed	77.15	0.00029	45.0	35.0	20.4	0.065	
K-only, HEMT-1, RCP, 27.0 GHz, Non-Diplexed	77.52	0.00029	45.0	26.7	19.6	0.05	
K-only, HEMT-2, LCP, 27.0 GHz, Non-Diplexed	77.52	0.00029	45.0	26.6	19.6	0.05	
S/K, HEMT-1, RCP, 27.0 GHz, Non-Diplexed	77.48	0.00029	45.0	36.4	20.4	0.065	
S/K, HEMT-2, LCP, 27.0 GHz, Non-Diplexed	77.48	0.00029	45.0	36.3	20.4	0.065	

NOTE:

For low-gain mode add +180 K to T_1 values (K-band)

Table A-4. Ka-Band Vacuum Gain and Antenna-Microwave Noise Temperature Parameters, Referenced to Feedhorn Aperture

Station and Configuration	Vacuum Gain Parameters				Antenna-Microwave Noise Temperature Parameters			Figures
	G ₀ Transmit	G ₀ Receive	G ₁	γ	T ₁	T ₂	a	
DSS-25 (Goldstone)								
Ka-Only, HEMT-1, RCP, Diplexed	79.52	79.00	0.00052	45.00	27.66	3.4	0.030	
Ka-Only, HEMT-2, RCP-error, Diplexed	-	-	-	-	27.07	3.4	0.030	
X/Ka, HEMT-1, RCP, Diplexed	79.37	78.85	0.00052	45.00	31.18	3.4	0.030	Figure 18 Figure 35
X/Ka, HEMT-2, RCP-error, Diplexed	-	-	-	-	35.30	3.4	0.030	
DSS-26 (Goldstone)								
X/Ka, HEMT-1, RCP, Non-Diplexed	-	79.13	0.00022	44.38	19.35	5.0	0.075	Figure 19 Figure 36
X/Ka, HEMT-2, RCP-error, Non-Diplexed	-	-	-	-	24.54	5.0	0.075	
X/Ka, HEMT-3, LCP, Non-Diplexed	-	79.13	0.00022	44.38	20.76	5.0	0.075	
DSS-34 (Canberra)								
X/Ka, HEMT-1, RCP, Non-Diplexed	-	78.98	0.00031	44.30	19.38	0.0	0.000	Figure 20 Figure 37
X/Ka, HEMT-2, RCP-error, Non-Diplexed	-	-	-	-	23.25	0.0	0.000	
X/Ka, HEMT-3, LCP, Non-Diplexed	-	78.98	0.00031	44.30	19.61	0.0	0.000	
DSS-35 (Canberra)								
X/Ka, HEMT-1, RCP, Non-Diplexed	-	79.27	0.00031	45.00	17.3	1.0	0.1	Figure 21 Figure 38
X/Ka, HEMT-2, RCP-error, Non-Diplexed	-	-	-	-	TBD			
X/Ka, HEMT-3, LCP, Non-Diplexed	-	79.27	0.00031	45.00	17.2	1.0	0.1	

Table A-4. Ka-Band Vacuum Gain and Antenna-Microwave Noise Temperature Parameters, Referenced to Feedhorn Aperture (continued)

Station and Configuration	Vacuum Gain Parameters				Antenna-Microwave Noise Temperature Parameters			Figures
	G ₀ Transmit	G ₀ Receive	G ₁	γ	T ₁	T ₂	a	
DSS- 36 (Canberra)								
X/Ka, HEMT-1, RCP, Non-Diplexed	-	79.34	0.00060	47.52	12.54	-13.0	0.060	Figure 22 Figure 39
X/Ka, HEMT-2, RCP-error, Non-Diplexed	-	-	-	-	TBD	0.0	0.000	
X/Ka, HEMT-3, LCP, Non-Diplexed	-	79.34	0.00060	47.52	12.18	-12.8	0.060	
DSS-54 (Madrid)								
X/Ka, HEMT-1, RCP, Non-Diplexed	-	78.38	0.00020	45.00	21.80	0.0	0.000	
X/Ka, HEMT-2, RCP-error, Non-Diplexed	-	-	-	-	25.00	0.0	0.000	
X/Ka, HEMT-3, LCP, Non-Diplexed	-	78.38	0.00020	45.00	21.80	0.0	0.000	
DSS-55 (Madrid)								
X/Ka, HEMT-1, RCP, Non-Diplexed	-	79.13	0.00022	45.00	20.79	5.3	0.076	Figure 23 Figure 40
X/Ka, HEMT-2, RCP-error, Non-Diplexed	-	-	-	-	21.97	5.3	0.076	
X/Ka, HEMT-3, LCP, Non-Diplexed	-	79.13	0.00022	45.00	19.82	5.3	0.076	

NOTES:

G₀ values are nominal at the frequency specified in Table 4 and Table 7. Other parameters apply to all frequencies within the same band. The nominal Ka-band uplink frequency is 34300 MHz. The nominal Ka-band downlink frequency is 32000 MHz.

The T₂ coefficients for DSS-36 Ka-band are both negative.

For low-gain mode add +70 K to T₁ values (Ka-band).

Table A-5. S-, X-, K-, and Ka-Band Zenith Atmospheric Attenuation (A_{zen})

Station	A_{zen} , dB			
	Cumulative Distribution = 0.00	Cumulative Distribution = 0.25	Cumulative Distribution = 0.50	Cumulative Distribution = 0.90
S-Band				
Goldstone	0.033	0.033	0.034	0.034
Canberra	0.036	0.036	0.036	0.037
Madrid	0.035	0.035	0.035	0.036
X-Band				
Goldstone	0.037	0.039	0.040	0.047
Canberra	0.039	0.044	0.046	0.058
Madrid	0.038	0.042	0.045	0.055
K-Band				
Goldstone	0.078	0.125	0.150	0.232
Canberra	0.083	0.176	0.212	0.387
Madrid	0.082	0.153	0.186	0.385
Ka-Band				
Goldstone	0.116	0.149	0.167	0.260
Canberra	0.124	0.195	0.229	0.403
Madrid	0.121	0.181	0.217	0.361

NOTE:

Values from Module 105, Rev. D