



Deep Space Network

206

Telemetry General Information

Document Owner:

Approved by:

Signature provided 08/04/2021
Andrew O'Dea Date
TT&C System Engineer

Signature provided 06/29/2021
Timothy Pham Date
Communications Systems Chief
Engineer

Prepared by:

Released by:

Signature provided 08/04/2021
Scott Allen Date
DSN Support System Engineer

Signature provided 08/05/2021
Christine Chang Date
DSN Document Release Authority

DSN No. **810-005, 206, Rev. D**
Issue Date: September 01, 2021
JPL D-19379; CL#21-3810

Jet Propulsion Laboratory
California Institute of Technology

Users must ensure that they are using the current version in DSN Telecommunications Link Design Handbook website:
<https://deepspace.jpl.nasa.gov/dsndocs/810-005/>

© <2021> California Institute of Technology.
Government sponsorship acknowledged

Review Acknowledgment

By signing below, the signatories acknowledge that they have reviewed this document and provided comments, if any, to the signatories on the Cover Page.

Signature provided	05/19/2021
_____ Jeff Berner DSN Project Chief Engineer	Date

Signature not provided	_____
Harvey Soldan DSN Systems Engineer	Date

Signature not provided	_____
Bo Cen DTT Telemetry Subsystem Engineer	Date

Signature provided	06/30/2021
_____ Stephen Slobin DSN Systems Engineer	Date

Document Change Log

Rev	Issue Date	Prepared By	Affected Paragraphs	Change Summary
Initial	10/7/2004	L. Paal	All	All
Rev. A	9/19/2008	R. Sniffin	Many	Added 34-m and 70-m array information originally planned for inclusion in module 215. Deleted references to portions of AMMOS that are responsibility of projects and to the GDSCC 26-m antenna that has been decommissioned. Added Near-earth 26 GHz (K-band) support and revised proposed capabilities
Rev. B	10/31/2009	A. Kwok	Many	Removed all references related to the 26-m stations.
Rev. C	05/03/2017	S. Allen	Most of sections 2, 3 and 4; removal of section 5. Minor changes in section 1.	Update to reflect current and near future station changes, update Figure 1 and Table 2 to reflect station changes, update to reflect projected capabilities that are now implemented capabilities.
Rev. D	09/01/2021	S. Allen	ALL	Minor updates to reflect current and near future station changes. Update to Figure 1 to reflect station changes. Addition of LDPC rates. Addition of DSS-56 and DSS-53.

Contents

<u>Paragraph</u>	<u>Page</u>
1 Introduction.....	6
1.1 Purpose.....	6
1.2 Scope.....	6
1.3 Relation to Other 810-005 Material.....	6
1.3.1 Telecommunications Interface Modules	6
1.3.2 Environmental Effects	6
1.3.3 Receiver Performance	7
1.3.4 Arraying.....	7
1.3.5 Telemetry Decoding	7
1.3.6 Other Factors	7
2 General Information.....	7
2.1 Telemetry Services.....	11
2.2 Facilities and Equipment.....	11
2.2.1 Antennas	11
2.2.2 Telemetry Receivers.....	12
2.2.3 Telemetry Processing	13
2.2.4 Ground Communications Network	13
2.2.5 DSN Data Delivery	14
2.3 Concepts Used in Estimating Telemetry Performance	16
2.3.1 Relative Power of Telemetry Signal Components	16
2.3.2 Definition of STB/N0 and STSY/N0 (dB)	17
2.3.3 Carrier Loop SNR	18
2.3.4 Arraying.....	18
3 Typical Performance.....	20
4 Recommendations for Mission Design.....	20
4.1 Operating Frequency.....	20
4.1.1 S-band (2.2 – 2.3 GHz)	22
4.1.2 K-band (25.5 – 27.0 GHz).....	22
4.1.3 X-band (8.4 – 8.5 GHz).....	22
4.1.4 Ka-band (31.8 – 32.3 GHz).....	22
4.2 Telemetry Modulation	23
4.2.1 Residual-Carrier BPSK	23
4.2.2 Suppressed-Carrier BPSK	23
4.2.3 QPSK and OQPSK.....	23
4.3 Symbol Formats	24

4.4	Coding Schemes.....	24
4.4.1	Uncoded.....	24
4.4.2	Reed-Solomon Code.....	24
4.4.3	Short Constraint Length, Rate 1/2 Convolutional Code.....	25
4.4.4	Concatenated Reed-Solomon and Rate 1/2 Convolutional Codes	25
4.4.5	Long Constraint-Length, Higher-Rate Convolutional Codes.....	25
4.4.6	Turbo Codes	25
4.4.7	Low-density Parity-Check Codes.....	25
4.4.8	Derandomization	25
5	Proposed Capabilities	26
5.1	Bandwidth-efficient Modulation.....	26

Illustrations

<u>Figure</u>	<u>Page</u>
Figure 1. DSN Telemetry Equipment for Spacecraft Support.....	9
Figure 2. X-band Telemetry Performance with Reference Spacecraft	20
Figure 3. Ka-band Telemetry Performance with Reference Spacecraft	21

Tables

<u>Table</u>	<u>Page</u>
Table 1. Telemetry Support Capability.....	10
Table 2. Frequencies Covered and Sensitivity of DSN Antennas for Telemetry	12
Table 3. 34-m and 70-m Telemetry Reception Characteristics	14
Table 4. Definition of $\alpha(\theta)$ and $\beta(\theta)$ for θ in radians, peak.....	16
Table 5. Relative Telemetry Aperture	19
Table 6. Reference Spacecraft Characteristics.....	21

1 Introduction

1.1 Purpose

This module is intended to provide Deep Space Network (DSN) customers with an overview of DSN telemetry capability and to direct telecommunications designers with specific concerns to the appropriate portions of this handbook. This module also contains brief descriptions of future enhancements to telemetry capability that are in the design or early implementation phases and of capabilities that are being maintained for legacy customers using the previous generation of telemetry equipment.

1.2 Scope

This module describes the Telemetry Service as currently implemented in the DSN. It includes high-level definitions, equations, functional descriptions, and capabilities to provide the telecommunication designer with an introduction to the more detailed information in the other modules of this handbook. Some characteristics are extracted from these modules for the readers' convenience and information relating to telemetry reception that does not conveniently fit in the major divisions of this handbook is included. Schedules for proposed implementation or the removal of any legacy support are not included. All questions relating to schedule should be directed to the Customer Interface Management Office (910).

1.3 Relation to Other 810-005 Material

The information necessary to properly design a telemetry link is distributed across many modules of this handbook. The following paragraphs discuss these modules and describe the parameters contained in them that should be of interest to a telecommunications link designer.

1.3.1 Telecommunications Interface Modules

Modules 101, 103, and 104 contain the radio frequency (RF) characteristics of the Deep Space Network (DSN) antennas. These characteristics include the frequencies of operation, antenna gain, system noise temperature, beamwidth, and polarization capability. A block diagram of each antenna's microwave equipment is also included.

1.3.2 Environmental Effects

Module 105 provides the model for attenuation effects of the Earth's atmosphere on the telecommunications link. Statistics are provided from which a confidence level for link performance can be derived. Limited information on wind effects is provided as a guide for

estimating when the antennas may not be available. The module also includes information on solar, lunar, and planetary noise that will be experienced when the antenna beam is in their vicinity when tracking spacecraft.

Module 106 provides information on additional effects caused by the solar wind or corona when the antenna beam passes near the sun.

1.3.3 Receiver Performance

The telemetry receiver used in the 34-m and 70-m stations is described in module 207. This module provides information on the types of telemetry modulation that can be accommodated and recommendations on carrier loop bandwidth, subcarrier frequency, modulation index, and data rate for each modulation type. Also included is a discussion of system losses for each modulation type.

The 34-m and 70-m stations may make use of the open-loop Radio Science receiver to record an appropriate segment of the received spectrum for post-pass processing. The characteristics of this receiver are described in module 209, however the process of extracting telemetry from radio science receiver recordings is not a standard DSN Service and is not covered in this handbook.

1.3.4 Arraying

The 34-m antennas at each complex can be combined into an array with or without the co-located 70-m antenna. The capabilities of such an array are discussed in paragraph 2.3.4.

1.3.5 Telemetry Decoding

Telemetry decoding capability for the 34-m and 70-m stations is covered in module 208.

1.3.6 Other Factors

Although not of primary interest, the telemetry link designer may be interested in coverage limits presented in module 301 and antenna mechanical performance, including open-loop beam positioning, presented in module 302. Test support provided by the DSN may also be of interest and is described in module 305.

2 General Information

Telemetry service support is available from the three Deep Space Communication Complexes (DSCCs) located in Goldstone, California, USA (GDSCC), near Canberra, Australia (CDSCC), and near Madrid, Spain (MDSCC). Telemetry support is also available from the DSN development and test facility, DTF-21, near JPL, the Merritt Island Launch Area also known as MIL-71 at the Kennedy Space Center, and the transportable Compatibility Test Trailer, CTT-22. CCSDS (Consultative Committee for Space Data Communications) Space Link Extension (SLE)

data is available from JPL. All data types including SLE are routed by the Ground Networks Subsystem (GNW) to JPL before delivery to the users.

810-005
206, Rev. D

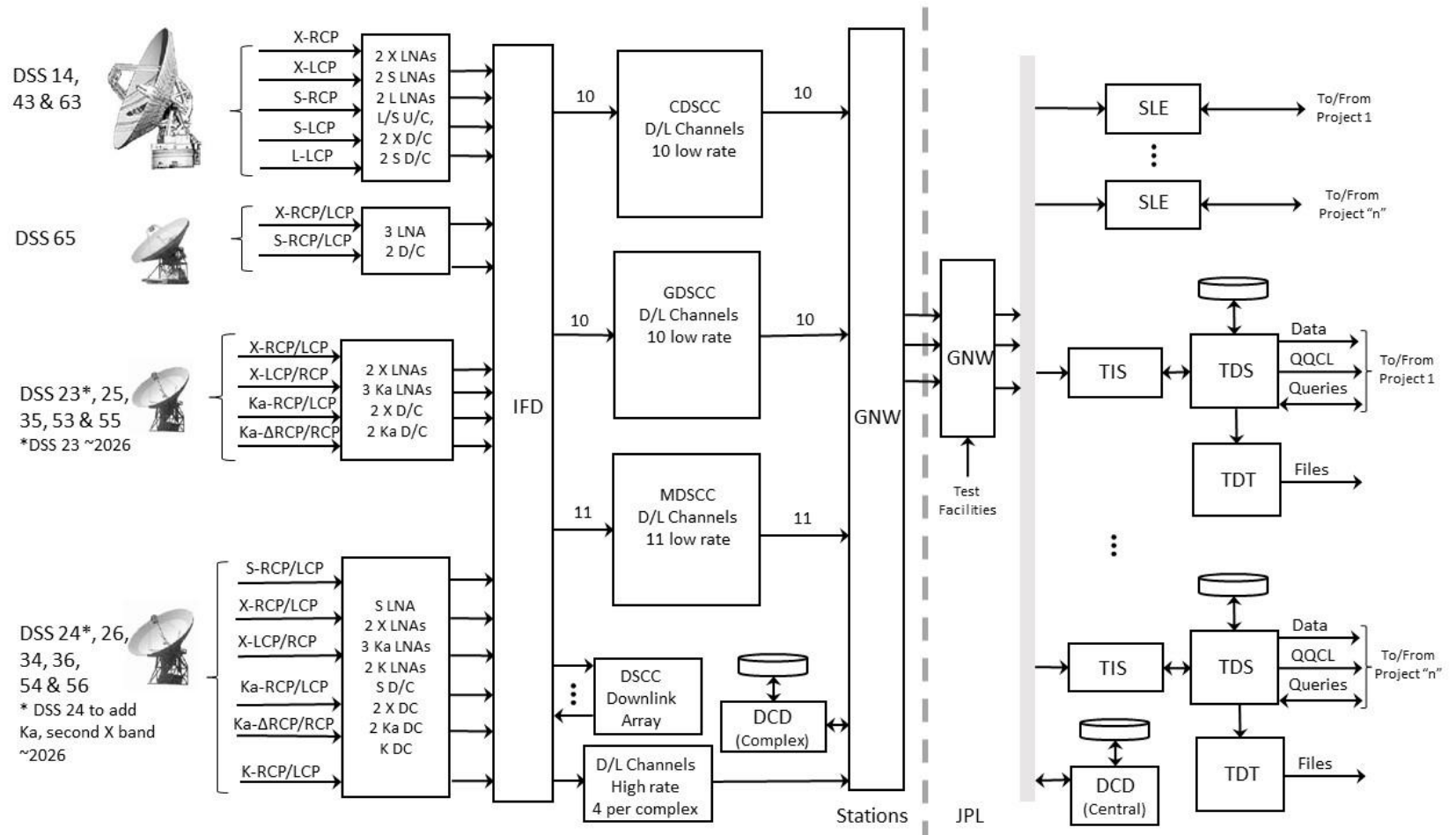

Figure 1. DSN Telemetry Equipment for Spacecraft Support

Figure 1 shows the DSN equipment used for telemetry service support. The items shown on the figure are discussed below.

In general, telemetry service support requires one antenna, at least one receiver, and telemetry processing equipment for each spacecraft. Additional receivers and telemetry processing equipment can be added for spacecraft with multiple downlinks or for redundancy. In addition, the DSN is capable of tracking up to four spacecraft per antenna (MSPA) if they all are within the scheduled antenna's beamwidth.

The DSN makes every attempt to provide the same functions in every instantiation of the Telemetry Service (TLM). There is one exception for historical reasons. There are only two copies of the long constraint length convolutional decoder at each complex as it was originally implemented to support a specific mission. Missions that require this decoder must schedule its use and be aware of the potential for conflicts. Note: The long constraint length decoder is not available to new missions.

Table 1 summarizes the DSN telemetry service support available from each complex.

Table 1. Telemetry Support Capability

Capability	Value	Remarks
Number of simultaneous spacecraft tracks per complex	GDSCC = 7 CDSCC = 7 MDSCC = 8	Based on the number of antennas plus three for MSPA
MSPA	One antenna per complex	MSPA is presently limited to four spacecraft
Frequency bands supported	S, X, K ¹ , and Ka	Depends on antenna.
Polarization	Right-hand circular (RCP) or left-hand circular (LCP)	Simultaneous RCP and LCP is available on some antennas
Arraying	All 34-m and 70-m antennas within one complex	Uses full-spectrum combining. See paragraph 2.3.4

¹ K-band and 26 GHz are used interchangeably and refer to the near-earth 25.5 – 27.0 GHz band. They are distinct from Ka-band (also referred to as 32 GHz band), which refers to the deep space 31.8 – 32.3 GHz band.

2.1 Telemetry Services

Two distinct types of telemetry service are available. The first of these is the traditional return link from a spacecraft that may carry engineering or science data as one of several forms of telemetry modulation including residual-carrier or suppressed-carrier binary-phase-shift keying (BPSK), quadrature-phase-shift keying (QPSK), or offset QPSK (OQPSK). The second is the beacon mode service that is intended to monitor the high-level state of a spacecraft during periods when insufficient link margin prevents the reception of traditional telemetry.

2.2 Facilities and Equipment

2.2.1 Antennas

Each Deep Space Communications Complex contains one 70-m and from three to four 34-m antennas. There are two types of 34-m antennas. The first is the high-efficiency (HEF) antennas that have their feed, low-noise amplifiers, and transmitter located on the tilting structure of the antenna. These antennas were the first antennas in the DSN to use dual shaped reflectors (main reflector and subreflector) instead of conventional paraboloid and hyperboloid shapes. The efficiency of all DSN 34-m antennas is now approximately the same. Note that the 34-m HEF antennas are being decommissioned and will not be available in the future. DSS-45 and DSS-15 have already been taken off-line. DSS-65 decommission is expected in the future (TBD). The second type of 34-m antenna is the beam waveguide (BWG) antenna where the feeds, low noise amplifiers and transmitters are located in a room below the antenna structure and the radio frequency energy is transferred to and from the antenna surface by a series of mirrors encased in a protective tube. All antennas that are designed to receive S- or X-band can receive either RCP or LCP in these bands. Antennas with two low noise amplifiers (LNAs) and downconverters in either of these bands can receive simultaneous RCP and LCP. All antennas that receive 26 GHz (K) or 32 GHz (Ka) bands are designed to receive RCP. Five of the six antennas that receive 32 GHz can receive LCP provided that autotrack (monopulse) capability is not required.

The capabilities of each antenna type and of the individual Beam Waveguide (BWG) antennas are different and must be considered in designing a return link. The selection of antenna will depend on the downlink frequencies it supports and the gain it can provide. Table 2 lists the uplink and downlink frequency ranges for each antenna type and the sensitivity, expressed as the ratio of antenna gain to system temperature, at the time this module was published. The modules referred to in Section 1.3.1 should be consulted for current values and other parameters. The telecommunications link designer is cautioned against making designs dependent on the 70-m antenna as there is only one per complex and it is subject to severe scheduling constraints.

Table 2. Frequencies Covered and Sensitivity of DSN Antennas for Telemetry

Antenna type	Downlink Frequency Ranges (MHz)	Sensitivity (G/T, dB) (See Note 1)	GDSCC	CDSCC	MDSCC
70-m	2270 – 2300	48.3 – 50.9	1	1	1
	8400 – 8500	60.9 – 61.7			
34-m HEF (Note 2)	2200 – 2300	39.1 – 39.8	0	0	1
	8400 – 8500	53.2– 54.6			
34-m BWG S/X/K/Ka (Notes 3 and 4)	2200 – 2300	40.6 – 42.2	4 (Note 5)	3	4
	8400 – 8500	51.3 – 55.2			
	25500 – 27000	58.2 – 60.2			
	31800 – 32300	60.1 – 62.5			

Notes:

1. Range covers best performing antenna with 90% weather (see module 105) at band center and 45-degrees elevation in highest sensitivity configuration (usually one band, downlink only) to worst performing antenna at band center and peak gain point in lowest sensitivity configuration (usually dual band downlink or backup LNA with uplink in one band). See appropriate telecommunications interface modules (101, 103 and 104) for complete performance envelope and module 105 for atmospheric effects. In the context of this document, G/T is defined as effective antenna gain divided by system noise temperature, including the effects of atmospheric attenuation and noise temperature contribution.
2. The 8200 – 8600 MHz (VLBI) band uses a wideband HEMT LNA with generally lower performance than the maser LNA that supports only the 8400 – 8500 MHz frequency range. See module 103.
3. S-Band capability is available at DSS-24, -26, -34, -36 -54 & -56. K-band capability is available at DSS-24, -26, -34, -36, -54 & -56 – NOTE: DSS-26 K-band capability ~2/2022, DSS-36 K-band capability ~12/2022. K-band implementation includes a special low G/T mode for high signal level conditions. Some X and Ka-band BWG antennas also allow for the same higher input signal power.
4. Wide range of K- and Ka-band performance results from much lower atmospheric contribution at GDSCC compared with that at CDSCC and MDSCC. Wide range of X-band performance results from use of partially-cooled X/X/Ka-band feeds at all BWG antennas except DSS-24, compared with the room-temperature feeds at DSS-24.
5. Includes DSS23 expected ~2026.

2.2.2 Telemetry Receivers

All DSN antennas employ a receiver architecture where one or both circular polarizations of the received spectrum are amplified by an LNA and translated to an intermediate frequency by a downconverter (D/C) before being routed to the control room where the desired signal is extracted. The antennas are designed to receive extremely weak signals and can be

overloaded by signals in excess of -90 dBm. Antennas supporting K-band have a special low-gain mode that permits operation up to -50 dBm with degraded G/T. Some X and Ka-band BWG antennas also allow for the same higher input signal power. Missions must be careful to not exceed these limits when designing for near-Earth operations.

Each S-, X-, K-, and Ka-band intermediate frequency from the 34-m and 70-m stations is made available to from one to four sets of receiving and telemetry processing equipment in the SPC. The additional receivers can be used to provide redundancy or reception for additional return links from the supported spacecraft. Additional redundancy can be obtained at S-band and X-band from some stations with simultaneous RCP and LCP capability by setting both downconverters to the same polarization. The following is a brief discussion of the DSN telemetry receivers. Their characteristics are summarized in Table 3.

Each receiver for the S-, X-, K-, and Ka- bands at the 34-m and 70-m antennas is contained in an assembly referred to as a *Downlink Channel*. The receiver utilizes a closed-loop digital super-heterodyne receiver with a selectable carrier tracking loop bandwidth to produce an 8-bit estimated symbol value as its output. Alternatively, these receivers can be used to detect the presence or absence of one of four subcarriers referred to as beacon tones. A complete discussion of the capabilities of this receiver is contained in module 207 of this handbook.

The receiver for K-band is part of a special Downlink Channel containing a wideband telemetry processor. The receiver is preceded by a fixed-frequency downconverter in the antenna and a step-tunable downconverter in the control room.

2.2.3 Telemetry Processing

Telemetry processing at the stations is available for both CCSDS and non-CCSDS (legacy) spacecraft. A summary of the capabilities for these stations is provided in Table 3.

At the stations, the digital symbol output of the telemetry receiver is time-tagged, subjected to optional decoding and frame synchronization, virtual channel extraction and formatting of the data for delivery to the customer. Decoding and frame synchronization are discussed in module 208 of this handbook.

Real-time data delivery may sometimes be limited to critical data. The remainder will be delivered non real-time within an agreed timeframe.

2.2.4 Ground Communications Network

The GNW uses communications circuits provided by the NASA Communications (NASCOM) infrastructures provided by the NASA Communications Program to connect the stations to JPL Central. The communication lines are shared with all users. The bandwidth is scoped such that it would meet the latency requirements from various missions.

2.2.5 DSN Data Delivery

The DSN provides CCSDS SLE data delivery through the DSN central facility at JPL. Data delivery for additional telemetry functions such as packet extraction (for legacy missions) and CCSDS File Delivery Protocol (CFDP) file processing is also from the DSN central facility.

Table 3. 34-m and 70-m Telemetry Reception Characteristics

Parameter	S-, X-, and Ka-band Characteristics	K-band Characteristics*
Receiver Type	Digital	Digital
Closed-loop Carrier Loop Bandwidth (1 sided)	0.2 Hz – 100 Hz	0.1% of symbol rate
Carrier Tracking	Residual Carrier or Suppressed Carrier	Suppressed Carrier
Pre-digitization Bandwidth	66 MHz	400 MHz
Modulation Types	Residual Carrier BPSK with or without subcarrier, Suppressed Carrier BPSK, QPSK, OQPSK	Suppressed Carrier BPSK, QPSK, OQPSK
Subcarrier Frequencies	500 Hz – 2.0 MHz	Not Available
Subcarrier Data Rate (Residual Carrier)	4 s/s – 0.67 X f_subcarrier (s/s)	Not Available
Subcarrier Data Rate (Suppressed Carrier)	20 X loop B/W (s/s) – 0.67 X f_subcarrier (s/s)	Not Available
Direct Modulation (Residual Carrier)	10 ks/s – 26 Ms/s (NRZ) 100 s/s – 13 Ms/s (Bi-phase)	Not Available
Direct Modulation (Suppressed Carrier)	20 X loop B/W (s/s) – 26 Ms/s (NRZ) 20 X loop B/W (s/s) – 13 Ms/s (Bi-phase) 40 ks/s – 26 Ms/s (QPSK or OQPSK)	1 Ms/s to 300 Ms/s
Beacon Mode	1 of 4 tones, SNR > 5 dB-Hz	Not Available
Data Formats	NRZ (-L, -M, -S) Bi-phase (-L, -M, -S)	NRZ (-L, -M, -S) Bi-phase -L

Parameter	S-, X-, and Ka-band Characteristics	K-band Characteristics*
Available Decoding	Short and long Constraint Convolutional, Reed-Solomon, Concatenated Convolutional and Reed-Solomon, Turbo, LDPC	Short Constraint Convolutional, Reed-Solomon, Concatenated Convolutional and Reed-Solomon, LDPC
Short Constraint Convolutional Decoding	k=7, r=1/2 CCSDS or DSN Connection vector, Optional De-randomization and alternate symbol inversion 26.4 Ms/s (max)	k=7, r=1/2 CCSDS Connection vector, Optional De-randomization 300 Ms/s (max)
Long Constraint Convolutional Decoding (for legacy mission only)	k=15 r=1/6 6.6 Ms/s (max)	Not Available
Frame Synchronization	CCSDS and non-CCSDS, 13.2 Mb/s (max)	CCSDS, 300 Ms/s (Max)
Reed-Solomon Decoding	RS (255, 223), Interleave = 1 – 8	RS (255, 223), Interleave = 1 – 8
Turbo Decoding Frame Size Code Rate and Data Rate	CCSDS 1784, 3568, 7136, 8920 1/2 (1.6 Mb/s, max) 1/3 (1.6 Mb/s, max) 1/4 (1.6 Mb/s, max) 1/6 (1.0 Mb/s, max)	Not Available
LDPC Decoding Frame Size Code Rate and Data Rate	CCSDS 1024, 4096, 16384 1/2 (5 Mb/s, max) 2/3 (5 Mb/s, max) 4/5 (5 Mb/s, max)) 7136 7/8 (223/255) (5 Mb/s, max)	Not Available Note: the capability for the 16k bit frames and the 7/8 code will be delivered in 2022.

* K-band characteristics based on the decommissioned RTLogic T720HDR specs, currently in use HRT specs not yet complete but should match closely.

2.3 Concepts Used in Estimating Telemetry Performance

The following concepts are important to understanding telemetry performance. A more detailed discussion of these concepts is contained in module 207 of this handbook.

2.3.1 Relative Power of Telemetry Signal Components

It is possible to share the available downlink power between more than one type of modulation when using residual carrier power modulation schemes. The functions $\alpha(\theta)$ and $\beta(\theta)$, as shown in Table 4, are used to describe the allocation of downlink power between two or more modulation types.

The equations below provide the component to total power relationships for any combination of the modulating signals identified as Channels 1 through 4 although it is rare that more than two types of modulation will be used. Power not accounted for by these equations is distributed as inter-modulation products and is not available to the communications process. The modulation indices, ϕ_N , for all equations must be in units of radians, peak, and the modulation index for the unused channels should be set to zero.

Table 4. Definition of $\alpha(\theta)$ and $\beta(\theta)$ for θ in radians, peak

Telemetry type	$\alpha(\theta)$	$\beta(\theta)$	Remarks
Square wave subcarrier or data only	$\cos(\theta)$	$\sin(\theta)$	$\beta(\theta)$ includes data power in all harmonics
Sine wave subcarrier	$J_0(\theta)$	$\sqrt{2}J_1(\theta)$	$\beta(\theta)$ only includes data power in fundamental harmonics

- (1) Channel 1 data (D_1) directly modulates the carrier with modulation index ϕ_1 .
- (2) Channel 2 data (D_2) bi-phase modulates a square-wave or sine wave subcarrier that is used to modulate the carrier with modulation index ϕ_2 .
- (3) Channel 3 data (D_3) bi-phase modulates a square wave or sine wave subcarrier that is used to modulate the carrier with modulation index ϕ_3 .

- (4) Channel 4 data (D_4) is a square wave or sine wave ranging signal that directly modulates the carrier with modulation index ϕ_4 .

The carrier suppression is

$$\frac{P_C}{P_T} = \left[\cos(\phi_1) \cdot \alpha(\phi_2) \cdot \alpha(\phi_3) \cdot \alpha(\phi_4) \right]^2 \quad (1)$$

The ratio of the available data power to total power for each of the data streams is

$$\frac{P_{D1}}{P_T} = \left[\sin(\phi_1) \cdot \alpha(\phi_2) \cdot \alpha(\phi_3) \cdot \alpha(\phi_4) \right]^2, \quad (2)$$

$$\frac{P_{D2}}{P_T} = \left[\cos(\phi_1) \cdot \beta(\phi_2) \cdot \alpha(\phi_3) \cdot \alpha(\phi_4) \right]^2, \quad (3)$$

$$\frac{P_{D3}}{P_T} = \left[\cos(\phi_1) \cdot \alpha(\phi_2) \cdot \beta(\phi_3) \cdot \alpha(\phi_4) \right]^2, \quad (4)$$

$$\frac{P_{D4}}{P_T} = \left[\cos(\phi_1) \cdot \alpha(\phi_2) \cdot \alpha(\phi_3) \cdot \beta(\phi_4) \right]^2. \quad (5)$$

2.3.2 Definition of ST_B/N_0 and ST_{SY}/N_0 (dB)

Telemetry signal-to-noise ratios (SNRs) are expressed as bit SNR (represented as either ST_B/N_0 or E_B/N_0) or symbol SNR (represented as either ST_{SY}/N_0 or E_S/N_0). The distinction between symbols and bits is that when the telemetry data are encoded prior to transmission, channel bits (information bits plus overhead such as frame sync and parity bits) are the input to the encoder and symbols are the output. When coded data are processed after receipt on the ground, the telemetry stream consists of symbols until converted to bits again by the decoder at which time any overhead bits are discarded. The relationship between ST_{SY}/N_0 and ST_B/N_0 is:

$$ST_{SY}/N_0 = \frac{1}{r} \cdot ST_B/N_0 \quad (6)$$

where

S = the data power as defined in equations (1), (2), or (3);

T_B = the bit period,

T_{SY} = the symbol period,

N_0 = the one-sided noise spectral density,

r = the number of symbols per bit.

Some typical values for r include:

- 1 for uncoded data,
- 2 for rate 1/2 convolutionally, turbo, or LDPC coded data,
- 6 for rate 1/6 convolutionally coded or turbo coded data,

2.3.3 Carrier Loop SNR

The DSN Telemetry provides the user with an estimate of E_S/N_0 . This can be used to calculate a value for Carrier Loop SNR that includes system losses. This provides both a way to validate link design and a way to determine the system loss in a controlled environment. The following equations provide the Carrier Loop SNR (ρ_L) where B_L is the one-sided carrier loop bandwidth.

$$\rho_L = \frac{E_S/N_0}{\tan^2 \phi \cdot T_{SY} \cdot B_L} \quad \text{for square wave subcarrier and direct modulation.} \quad (7)$$

$$\rho_L = \frac{(E_S/N_0) \cdot J_0^2(\phi)}{2J_2^2(\phi) \cdot T_{SY} \cdot B_L} \quad \text{for sine wave subcarrier modulation.} \quad (8)$$

When using these relationships with more than one data stream modulating the carrier, care should be taken to use the values of E_S/N_0 , T_{SY} , and ϕ that all pertain to the same data stream.

2.3.4 Arraying

The DSN Telemetry can combine the intermediate frequencies from the 70-m and 34-m antennas at each complex by full spectrum combining. The output of the Array Combiner appears to be another IF spectrum that can be selected by from one to four receivers.

Ideally, the combined telemetry SNR is:

$$\left(\frac{E_b}{N_0}\right)_{\Sigma} = \sum_{i=1}^n \left(\frac{E_b}{N_0}\right)_i \quad (9)$$

where

$$\left(\frac{E_b}{N_0}\right) = \quad \text{the telemetry SNR at the input of the } i^{\text{th}} \text{ receiver for the non-arrayed case}$$

$$n = \quad \text{the number of streams combined.}$$

The ratio of the array sum E_b/N_0 to the E_b/N_0 of the master antenna (usually the antenna with the highest individual E_b/N_0) is the array gain. The individual SNRs are proportional to the ratios of antenna sensitivity, G/T, at each of the contributing antennas. Table 5 is a tabulation of G/T ratios relative to a 34-m and 70-m antenna for individual antennas and for combinations of arrayed antennas. The antenna performance values used to calculate the values in this table are those of the average antenna for each antenna type listed in Table 2 at its peak gain elevation angle. Relative aperture will approach the ratio of the antenna areas at low elevation angles where the high atmospheric temperature component becomes dominant over the LNA temperature.

The values in the table must be considered approximations as they do not take into consideration the particular antennas being arrayed, the effects of varying elevation, and the selected support configuration (polarization, diplexed vs. non-diplexed, etc.). The “Equivalent (dB)” column has been reduced by 0.3 dB to accommodate the typical combining loss.

Note: K-band arraying is not supported.

Table 5. Relative Telemetry Aperture

Practical Arrays [Best Antenna, Arrayed Antenna(s)]	G/T Ratio Relative to Reference Antenna	Equivalent (dB) Less Combining Loss
Relative to 34-m BWG Antenna		
S-band, 34-m BWG & 34-m HEF	1.66	1.90
X-band, 2 34-m (BWG or HEF)	2	2.71
X-band, 3 34-m (BWG or HEF)	3	4.47
X-band, 3 34-m BWG and HEF	4	5.72
Ka-band, 2 34-m BWG	2	2.71
Relative to 70-m Antenna		
S-band, 70-m, 34-m BWG	1.12	0.18
S-band, 70-m, 34-m BWG & 34-m HEF	1.23	0.60
X-band, 70-m, 1 34-m (BWG or HEF)	1.18	0.42
X-band, 70-m, 2 34-m (BWG or HEF)	1.36	1.03
X-band, 70-m, 3 34-m (BWG or HEF)	1.53	1.55
X-band, 70-m, 3 34-m BWG and HEF	1.70	2.01

3 Typical Performance

Figure 2 and Figure 3 provide the expected performance at X-band and Ka-band using a reference spacecraft having the characteristics listed in Table 6. Spacecraft antenna size and transmitter power for the two bands have been made equal to provide a fair comparison. These figures illustrate that, all other factors being the same, the performance of the 34-m BWG antennas at Ka-band is essentially the same as the 70-m antennas at X-band. It is also evident that use of Ka-band omni-directional antenna for emergency purposes is not practical for most spacecraft.

4 Recommendations for Mission Design

4.1 Operating Frequency

The DSN supports telemetry reception in the S-, X-, K-, and Ka-bands. The trend in deep space communications (Category B spacecraft) has been towards the higher frequencies. Near-Earth (Category A) spacecraft have used S-band exclusively but are adopting K-band for high data rate applications.

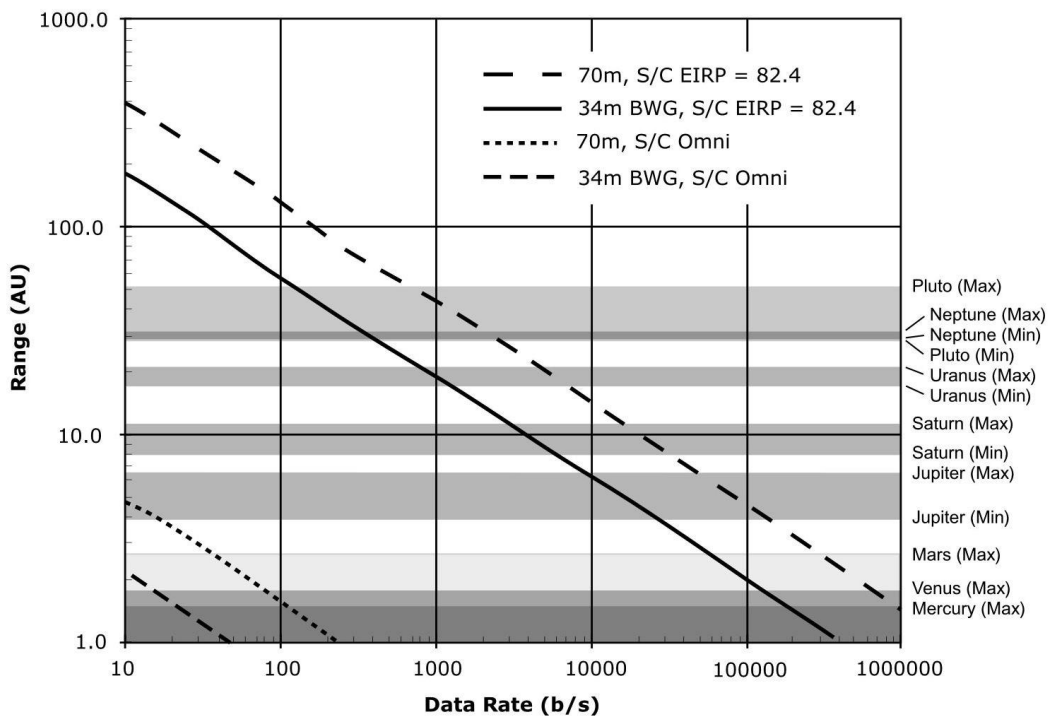

Figure 2. X-band Telemetry Performance with Reference Spacecraft

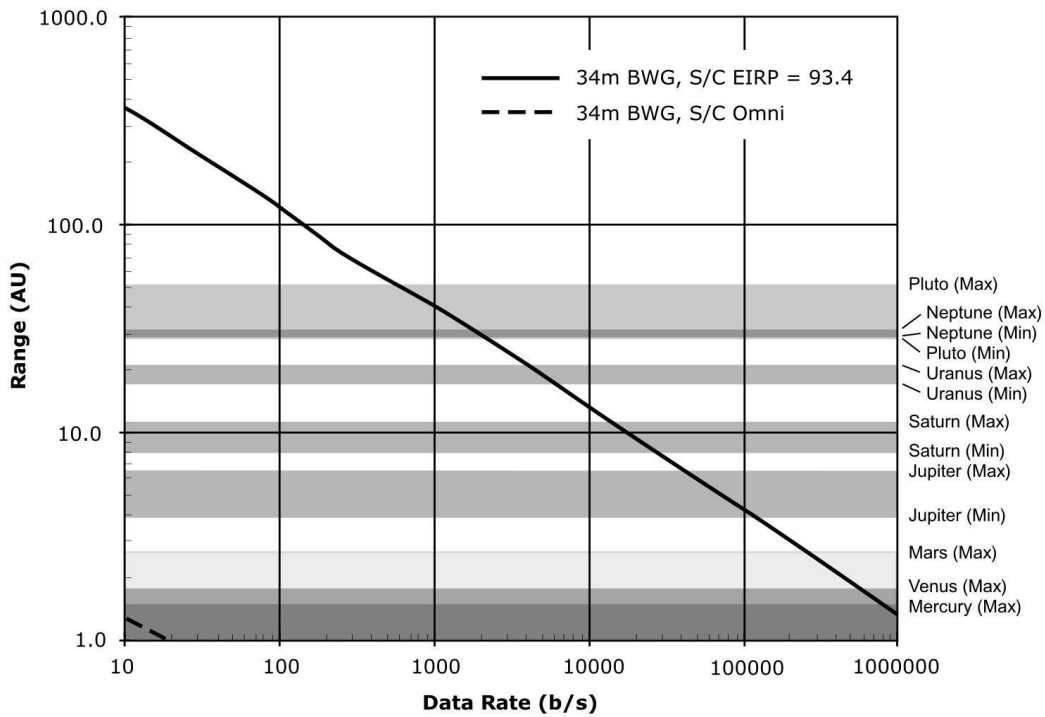

Figure 3. Ka-band Telemetry Performance with Reference Spacecraft

Table 6. Reference Spacecraft Characteristics

Parameter	X-band	Ka-band
Transmitter Power	35 W	35 W
Circuit Losses	2 dB	2 dB
Hi-gain Antenna (S/C HGA)	39 dB	50 dB
Pointing Loss (S/C HGA)	0.5 dB	1.5 dB
Coding	1784, $r=1/3$ Turbo	1784, $r=1/3$ Turbo
Weather	CD = 50	CD = 50
DSN Vacuum G/T	55.3 dB (34-m), 63.0 dB (70-m)	65.5 dB
Pointing Loss (DSN)	0.1 dB	0.1 dB
Margin	3 dB	3 dB

4.1.1 S-band (2.2 – 2.3 GHz)

S-band has been the frequency of choice for near-Earth spacecraft where link performance is relatively easy to obtain and the mass of spacecraft components is not as critical as with deep space spacecraft. Other advantages include the availability of low-cost spacecraft components and ground resources along with compatibility with the Goddard Spaceflight Center (GSFC)-managed Tracking and Data Relay Satellite System (TDRSS). The principal disadvantage of S-band for Category A spacecraft is that the total allocation bandwidth is 90 MHz. This creates a significant possibility of interference between spacecraft.

The principal advantage of S-band for deep space (Category B) spacecraft is low space loss that may be important for applications where there is little or no antenna gain at the transmitting (space) end of the link. Its disadvantages include larger spacecraft components, a limited channel bandwidth of 370 kHz, and significant link degradation when the link must pass near the sun. While it is possible to use more than one channel, the total deep space S-band allocation bandwidth is only 10 MHz.

4.1.2 K-band (25.5 – 27.0 GHz)

K-band is available for high data-rate, Category A (near-Earth) missions in combination with S-band for command and engineering telemetry. It provides an advantage of approximately 20 dB over an S-band link with equivalent specifications. Its principal disadvantage is degradation from adverse weather but this can be ameliorated by a combination of on-board data storage, weather forecasting, and an adaptive downlink data rate strategy.

4.1.3 X-band (8.4 – 8.5 GHz)

X-band is presently the most heavily used allocation for deep space missions. It is the highest frequency band in which uplink is currently supported making it possible to have a single-band spacecraft with a moderately high telemetry rate. The standard telemetry channel bandwidth at X-band is 1.4 MHz and, while missions may use more than one channel, the total X-band allocation bandwidth is only 50 MHz and the use of bandwidth-efficient modulation is preferred over multiple channel use.

4.1.4 Ka-band (31.8 – 32.3 GHz)

Ka-band is recommended for high data-rate missions in combination with X-band for command and engineering or emergency telemetry. It has no defined channels as its total allocation of 500 MHz cannot be accommodated with a single turn-around ratio from S- or X-band uplinks. It provides an advantage of approximately 9 dB over X-band for spacecraft with equivalent specifications and is the least susceptible to solar effects. Its principal disadvantages are degradation from adverse weather, high space loss that precludes use of an omni-directional antenna for emergency transmission, and somewhat greater spacecraft pointing requirements. Adverse weather effects can be ameliorated by a combination of on-board data storage, weather forecasting, and an adaptive downlink data rate strategy.

4.2 Telemetry Modulation

The DSN supports a wide range of telemetry modulation schemes. Some advantages and disadvantages of the various schemes are discussed in the following paragraphs. Additional information can be found in Module 207.

4.2.1 Residual-Carrier BPSK

Residual carrier BPSK using a square wave subcarrier is the modulation scheme that has been most commonly employed for deep space telemetry. There are historical reasons for this but it remains a good choice in many applications. A residual carrier provides the ability to share downlink power to support additional functions such as two-way ranging and Delta-differential One-way Ranging (Δ DOR). The ability of a spacecraft to provide an un-modulated carrier is also useful for Radio Science investigations. Residual carrier tracking tolerates a lower carrier loop SNR before experiencing cycle slips and is not subject to the more damaging half-cycle slips that are possible with suppressed carrier tracking. The subcarrier keeps the data sidebands away from the residual carrier in the frequency domain so the carrier can be tracked without interference. Use of a subcarrier occupies more spectrum than direct modulation, but the occupied bandwidth is typically not an issue for low data-rate telemetry.

Sine wave subcarriers have been used for Category A (near Earth) missions where relatively high power and wide antenna beamwidths make spectrum conservation essential. The higher-order harmonics of a sine wave subcarrier fall off faster with the result being that less bandwidth is occupied than by a square wave subcarrier of the same frequency. The disadvantage of sine wave subcarriers is that the receiver can recover only the power in the fundamental harmonics. Data power transmitted in the higher-order harmonics is lost. This is contrasted to square wave subcarriers where all data power within the bandwidth of the receiver is recovered.

Direct carrier modulation is a good choice for medium and high-rate telemetry when other considerations require a residual carrier. The baseline performance of this scheme is the same as that when using a square wave subcarrier and spectral occupancy is no more than half that of the equivalent square wave subcarrier system.

4.2.2 Suppressed-Carrier BPSK

Suppressed-carrier BPSK provides approximately the same performance at high data rates as residual-carrier BPSK and improved performance at some medium data rates. The bandwidth occupancy is the same as residual-carrier BPSK without a subcarrier. Suppressed-carrier BPSK can result in half-cycle slips and telemetry inversion, which is subsequently handled in frame synchronization. The half-cycle slips can also invert the ranging, which can be handled by configuring for automated detection of ranging polarity.

4.2.3 QPSK and OQPSK

QPSK and Offset QPSK offer better bandwidth efficiency than BPSK. For a given binary symbol rate, a QPSK or OQPSK carrier occupies only half the bandwidth of a

BPSK-modulated carrier (with no subcarrier). QPSK and OQPSK have the disadvantage that telemetry must be disabled in order to perform DSN ranging or Δ DOR.

The baseline telemetry performance of QPSK and OQPSK is the same as suppressed-carrier BPSK at high data rates. When shaped data pulses are used, there is some advantage to OQPSK, relative to QPSK, which accounts for the popularity of OQPSK in satellite communications; however, for unshaped data pulses, the performance and spectral occupancy of QPSK and OQPSK are the same. Note that for OQPSK modulation with shaped pulses (e.g., Gaussian Minimum-Shift Keying (GMSK) or Square Root Raised Cosine (SRRC) filtering), the DSN receivers can track the signal, but there are additional losses.

4.3 Symbol Formats

NRZ-L and biphase-L symbol formats are supported for all decoding schemes. Differentially encoded NRZ-M, NRZ-S, biphase-M and biphase-S formats are supported for uncoded and short constraint length convolutionally coded data (see below). The data is presented to downstream functions in NRZ-L format with differential decoding applied after convolutional decoding, if applicable.

4.4 Coding Schemes

Selection of coding scheme is independent of modulation scheme and involves the tradeoff of four considerations. These are coding gain, bandwidth, latency, and error floor. In general, coding gain increases with bandwidth and latency. More detailed information can be found in Module 208. The following coding schemes are supported by the DSN.

4.4.1 Uncoded

Uncoded data requires the least bandwidth and introduces the lowest latency. Its primary use is for transfer of extremely high data rates in bandwidth-limited situations when adequate link margin is available.

4.4.2 Reed-Solomon Code

The (255,223) Reed-Solomon (RS) code used by the DSN is capable of correcting up to 16 symbol errors out of each 255. The error-correcting capability provides a significant improvement over uncoded data with a modest bandwidth expansion but the lack of performance near threshold limits its use to high E_B/N_0 conditions.

4.4.3 Short Constraint Length, Rate 1/2 Convolutional Code

Short constraint length ($k = 7$), rate 1/2 convolutional code is a low-latency code that requires twice the bandwidth of uncoded data but provides coding gain for any input SNR. Its low latency makes it a good choice for low rate, emergency communications when recovery of data in real-time may outweigh the coding gain of higher-latency codes.

4.4.4 Concatenated Reed-Solomon and Rate 1/2 Convolutional Codes

When Reed-Solomon encoded spacecraft data is rate 1/2 convolutionally encoded before transmission, the resultant code has a slightly greater bandwidth expansion but significantly better performance at all SNRs than either of its components. This is because the convolutional decoder improves the input bit error rate to the Reed-Solomon decoder at low SNRs while the RS decoder improves the output error rate for all SNRs above its input threshold. As convolutional decoders tend to produce bursts of errors as they near their threshold, they can overwhelm the correction capability of the RS decoder. This can be alleviated by a technique called *interleaving* (See module 208) that trades improved performance for increased latency.

4.4.5 Long Constraint-Length, Higher-Rate Convolutional Codes

Long constraint-length convolutional codes with rates up to 1/6 offer significant improvements over the $k=7$, $r=1/2$ code but at the expense of bandwidth expansion of 6. As is the case with short constraint-length codes, they are usually concatenated with Reed-Solomon coding for better performance. Use of these codes is discouraged because of their limited support within the DSN.

4.4.6 Turbo Codes

Turbo codes provide near Shannon-limit performance with bandwidth expansions from slightly more than 2 to slightly more than 6. Block sizes of 1784, 3568, 7136, and 8920 symbols are accommodated. The smaller block sizes are intended for lower data rates while using larger block sizes as the data rate increases reduces coding overhead. Their principal disadvantages are the amount of processing that must be done to decode them and the presence of an error floor at a Frame Error Rate of about 10^{-6} . The decoding complexity limits the maximum supported data rate.

4.4.7 Low-density Parity-Check Codes

Low-Density Parity-Check codes conforming to the code family specified in Section 7 of the CCSDS Recommended Standard 131.0-B-2 are supported by the DSN. The decoding complexity limits the maximum supported data rate.

4.4.8 Derandomization

If the telemetry data is randomized as defined in CCSDS 131.0-B-2, derandomization is applied prior to frame (Reed-Solomon, turbo or LDPC) decoding.

5 Proposed Capabilities

The following paragraph discusses capabilities that have not yet been implemented by the DSN but have adequate maturity to be considered for spacecraft mission and equipment design. Telecommunications engineers are advised that any capabilities discussed in this section cannot be committed to except by negotiation with the Customer Interface Management Office (910).

5.1 Bandwidth-efficient Modulation

Several bandwidth-efficient modulation schemes are under consideration to permit the maximum amount of data to be returned within the allocated frequency bands. The most likely candidate for implementation is Gaussian minimum-shift keying (GMSK). This would remove the additional losses mentioned in section 4.2.3.