

**Deep Space Network**

# 209

## Open-Loop Radio Science

---

Document Owner:

Approved by:

Signature provided                      11/14/2023  
Dong Shin                                      Date  
OB System Engineer

Signature provided                      11/13/2023  
Timothy Pham                              Date  
Communications Systems Chief  
Engineer

Prepared By

Released by:

Signature provided                      11/19/2023  
Stephen Rogstad                              Date  
OLR Software CDE

Signature provided                      01/09/2024  
Christine Chang                              Date  
DSN Document Release Authority

DSN No. **810-005, 209, Rev. F**  
Issue Date: January 11, 2024  
JPL D-19379; CL#24-0315

---

**Jet Propulsion Laboratory**  
California Institute of Technology

*Users must ensure that they are using the current version in DSN Telecommunications Link Design Handbook website:*  
<https://deepspace.jpl.nasa.gov/dsndocs/810-005/>

© <2024> California Institute of Technology.  
U.S. Government sponsorship acknowledged.

## Review Acknowledgment

*By signing below, the signatories acknowledge that they have reviewed this document and provided comments, if any, to the signatories on the Cover Page.*

|                            |                   |
|----------------------------|-------------------|
| <u>Signature provided</u>  | <u>11/14/2023</u> |
| Jeff Berner                | Date              |
| DSN Project Chief Engineer |                   |

|                           |                   |
|---------------------------|-------------------|
| <u>Signature provided</u> | <u>11/14/2023</u> |
| Sue Finley                | Date              |
| OLR Subsystem Engineer    |                   |

***Document Change Log***

| <b>Rev</b> | <b>Issue Date</b> | <b>Prepared By</b>                       | <b>Affected Sections or pages</b> | <b>Change Summary</b>   |
|------------|-------------------|--|-----------------------------------|---|
| Initial    | 1/15/2001         | R. Sniffin                               | All                               | All   |
| A          | 6/1/2010          | A. Kwok                                  | All                               | Added Wideband VLBI Science Receiver (WVSR) and VLBI Science Receiver (VSR). Eliminated the Rev. E designation for the document series. |
| B          | 02/09/2015        | A. Bedrossian<br>S. Finley<br>D. Shin    | Section 2                         | Add DSS-35  |
| C          | 11/17/2016        | A. Bedrossian<br>D. Shin                 | Section 2                         | Add DSS-36<br>Remove DSS-45<br>Updated Figures<br>Some minor editorial corrections throughout the document                              |
| D          | 02/14/2019        | S. Rogstad<br>A. Bedrossian              | All                               | Updates for OLR Delivery<br>Remove DSS-15   |
| E          | 02/05/2021        | S. Rogstad<br>A. Bedrossian<br>S. Finley | Section 2                         | Added DSS-56 and DSS-53<br>Updated Table 2 and Table 3 information<br>Some minor editorial corrections                                  |
| F          | 01/11/2024        | D. Shin<br>S. Rogstad                    | Section 2                         | Updated DSS-53 status and added DDA annotation in Table 2   |
|            |                   |  |                                   |   |
|            |                   |  |                                   |   |
|            |                   |  |                                   |   |
|            |                   |  |                                   |   |

## *Contents*

| <b><u>Paragraph</u></b>          | <b><u>Page</u></b> |
|----------------------------------|--------------------|
| 1 Introduction.....              | 6                  |
| 1.1 Purpose.....                 | 6                  |
| 1.2 Scope.....                   | 6                  |
| 2 General Information.....       | 6                  |
| 2.1 Functions.....               | 6                  |
| 2.2 Hardware Configuration ..... | 7                  |
| 2.3 OLR Signal Processing.....   | 8                  |
| 2.4 Available IF Inputs .....    | 11                 |
| 2.5 OLR Signal Detection.....    | 11                 |
| 2.6 OLR Operation.....           | 12                 |
| 2.7 Data Delivery .....          | 13                 |
| 2.7.1 Ancillary Data.....        | 13                 |
| 2.8 Performance .....            | 13                 |
| 2.8.1 Frequency Stability .....  | 15                 |
| 2.8.2 Phase Noise.....           | 15                 |
| 2.8.3 Amplitude Stability.....   | 16                 |

## *Figures*

| <b><u>Figure</u></b>  | <b><u>Page</u></b> |
|---|--------------------|
| Figure 1. OLR Signal Flow.....                                | 7                  |
| Figure 2. Relationships between Processing Bands for OLR..... | 9                  |

## *Tables*

| <b><u>Table</u></b>  | <b><u>Page</u></b> |
|--|--------------------|
| Table 1 - Sample of OLR Supported Bandwidths .....                     | 10                 |
| Table 2 - Available IF Inputs at each complex .....                    | 12                 |
| Table 3. Open Loop Receiver Characteristics .....                      | 14                 |
| Table 4. Two-Way (Uplink and Downlink) Allan Deviation Estimates ..... | 16                 |
| Table 5. Uplink and Downlink Phase Noise Estimates .....               | 16                 |

## ***1 Introduction***

### ***1.1 Purpose***

This module describes the capabilities and performance of the Deep Space Network (DSN) open-loop receiving equipment used for supporting radio science (RS) experiments. Radio science experiments use the Open Loop Receiver (OLR) Subsystem.

### ***1.2 Scope***

This module discusses the open-loop radio science receiving equipment functions, architecture, operation, and performance. Although some RS experiments require uplink support and closed-loop Doppler and ranging data, this module only describes the open-loop recording capability that is used during radio science experiments. Open-loop recording is carried out by the OLR Subsystem. Details of the closed-loop Doppler tracking system can be found in module 202, Doppler Tracking. Details of the uplink functions can be found in the 70-m, the 34-m High Efficiency (HEF), and the 34-m Beam Waveguide (BWG) telecommunications interface modules 101, 103, and 104 respectively.

## ***2 General Information***

Radio science experiments involve measurements of small changes in the phase, frequency, amplitude, and polarization of the radio signal propagating from an interplanetary spacecraft to an Earth receiving station. By properly analyzing these data, investigators can infer characteristic properties of the atmosphere, ionosphere, and planetary rings of planets and satellites, measure gravitational fields and ephemerides of planets, monitor the solar plasma and magnetic fields activities, and test aspects of the theory of general relativity. Details of Radio Science System applications may be found in the JPL Publication 80-93, Rev. 1, written by S.W. Asmar and N.A. Renzetti, titled: *The Deep Space Network as an Instrument for Radio Science Research*. (<https://ntrs.nasa.gov/search.jsp?R=19950015039>).

### ***2.1 Functions***

The functions of the DSN with respect to conducting radio science experiments can be summarized as follows:

- Providing uplink carrier signals to the spacecraft with a pure spectrum, including low phase noise and stable frequency.
- Acquisition, down conversion, digitization, and recording of the downlink carrier with minimal changes to its frequency, phase, amplitude stability, and polarization.
- Assuring that the expected signals are being acquired and recorded.

## 2.2 Hardware Configuration

All radio science experiments require use of the antenna, microwave, antenna-mounted receiving equipment, and frequency and timing equipment at the stations, as well as the receivers in the signal processing center (SPC). They also require the Ground Communications Network (GCN) to deliver data from the stations to users at JPL, where experiments are monitored. A block diagram of the open-loop receiving capability is shown in Figure 1.

The receiving equipment on each DSN antenna produces one or more intermediate frequency (IF) signals with S-band producing an IF in the range 200 to 300 MHz; X-band 100-500 MHz and Ka-band 100-600 MHz. These IF signals are routed to an IF Gain Control (IGC) assembly and then digitized by the IF Digitizer (IFD). The IF digitizer channelizes the IF band and sends digital packets through the Digital IF Switch (DIS) to the OLR receivers.

Each of the 8 station OLRs can support up to 16 different IF inputs and each of the 16 possible configurable recording channels (see Table 1) can have a different BW, bit depth and static/predicted frequency configuration. However, limitations to this should be noted. An OLR should not be shared between users during a track, due to concerns about interference and having to divide up the available 16 channels. Users usually need multiple channels to record a given IF. Also, the total aggregate input bit rate of each OLR cannot exceed the 10Gbps Ethernet pipe.

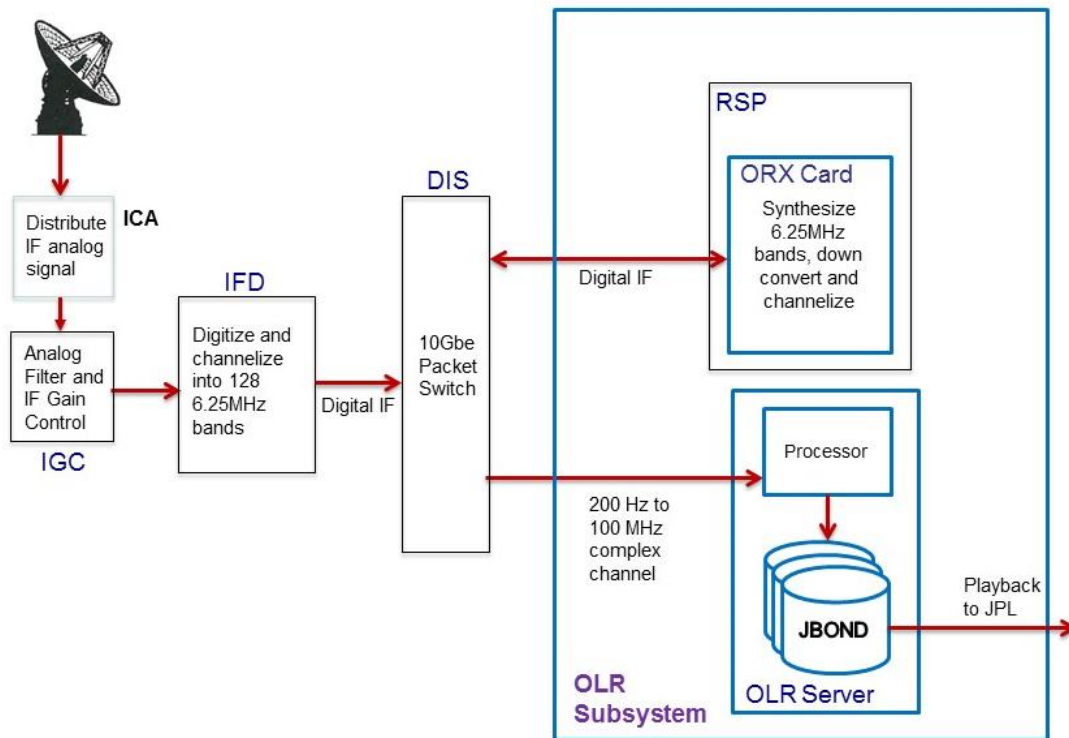

Figure 1. OLR Signal Flow

### **2.3**            ***OLR Signal Processing***

The IF signal is sampled in the IF Digitizer (IFD) where it is digitized and downconverted to 0-800MHz complex with a center frequency of 400MHz. However, the IF Gain Control (IGC) assembly filters the signal before entering the IFD to limit its bandwidth to the range of 85–609 MHz. This corresponds to a received frequency range of 2085-2609MHz at S-band, 8185-8709MHz at X-band, and 31785-32309MHz at Ka-band. However, the actual effective received frequency range will depend on the filter characteristics of the equipment on the selected antenna and may be narrower. Figure 2 illustrates the processing bandwidth through the OLR Subsystem.

The filtered IF signal is digitized at 3200 Ms/s with a 12-bit resolution, then downconverted to 0-800MHz complex with a center frequency of 400MHz and an equivalent resolution of 14 bits.

The recording channel filters are specified by their bandwidths, the desired resolution (bits/sample) and an offset from the predicted sky frequency predict file. This frequency predicts file is created by the DSN network support function and contains the spacecraft frequency altered by spacecraft trajectory and Earth-rotation. Table 1 lists a sample of the supported OLR filter bandwidths and resolutions. The OLR provides many other bandwidths and bit rates, however this table shows only those typically required by RS users. For a more exhaustive list of supported OLR channel bandwidths, see Section 3.2 of 820-013 0222-Science.



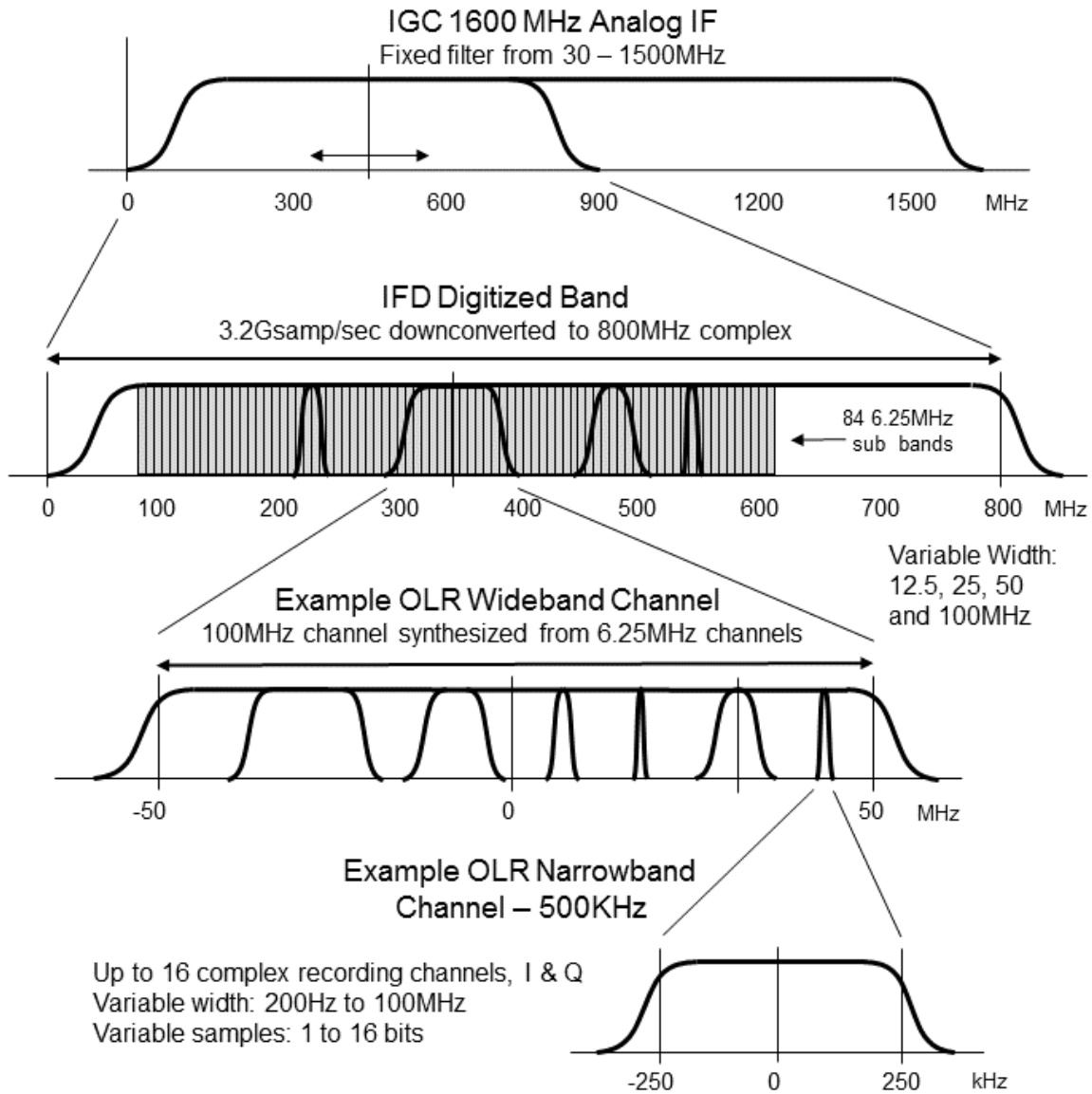

Figure 2. Relationships between Processing Bands for OLR

Table 1 - Sample of OLR Supported Bandwidths

| <b>Category</b> | <b>Bandwidth</b> | <b>Resolution (b/sample)</b> | <b>Upper Data Rate (b/s)</b> |
|-----------------|------------------|------------------------------|------------------------------|
| Narrowband      | 200 Hz           | 8,16                         | 6400                         |
|                 | 250 Hz           | 8,16                         | 8000                         |
|                 | 500 Hz           | 8,16                         | 16000                        |
|                 | 1 kHz            | 8,16                         | 32,000                       |
|                 | 2 kHz            | 8,16                         | 64,000                       |
|                 | 4 kHz            | 8,16                         | 128,000                      |
|                 | 8 kHz            | 8,16                         | 256,000                      |
|                 | 16 kHz           | 8,16                         | 512,000                      |
|                 | 25 kHz           | 8,16                         | 800,000                      |
|                 | 50 kHz           | 8,16                         | 1,600,000                    |
|                 | 80 kHz           | 8,16                         | 2,560,000                    |
|                 | 100 kHz          | 8,16                         | 3,200,000                    |
|                 | 250 kHz          | 8,16                         | 8,000,000                    |
|                 | 500 kHz          | 8,16                         | 16,000,000                   |
|                 | Wideband         | 1 MHz                        | 8,16                         |
| 2 MHz           |                  | 8,16                         | 64,000,000                   |
| 1 MHz           |                  | 2,4                          | 8,000,000                    |
| 2 MHz           |                  | 2,4                          | 16,000,000                   |
| 4 MHz           |                  | 2,4                          | 32,000,000                   |
| 8 MHz           |                  | 2                            | 32,000,000                   |
| 16 MHz          |                  | 2                            | 64,000,000                   |
| 32 MHz          |                  | 2                            | 128,000,000                  |
| 40 MHz          |                  | 2                            | 160,000,000                  |
| 50 MHz          |                  | 2                            | 200,000,000                  |

## **2.4            *Available IF Inputs***

Using a single client on a server, the OLR is capable of tracking and recording channels from up to 16 IF inputs at one time. These IF inputs available at each of the 3 DSN complexes are shown in Table 2.

## **2.5            *OLR Signal Detection***

The OLR does not have a mechanism to align its passband to (establish lock with, or track) the received signal. Instead, it relies on predicts to position its passband. This creates a risk that a predict error might result in the wrong portion of the received spectrum being processed. To assist in recognizing this, the OLR analyzes the data in each channel and provides a detected signal indication on the main display for that channel for diagnostic purposes only.

In addition to the detected signal indication, the OLR provides a frequency-domain representation of the bandpass being recorded in each channel using a Fast-Fourier Transform (FFT). Characteristics of the FFT such as number of points, averaging, and update rate are under user control.

Table 2 - Available IF Inputs at each complex

| Goldstone IF Inputs | Madrid IF Inputs | Canberra IF Inputs |
|---------------------|------------------|--------------------|
| 14_S1               | 63_S1            | 43_S1              |
| 14_S2               | 63_S2            | 43_S2              |
| 14_X1               | 63_X1            | 43_X1              |
| 14_X2               | 63_X2            | 43_X2              |
| 24_S1               | 65_S1            | 34_S1              |
| 24_X1               | 65_X1            | 34_X1              |
| 25_X1               | 54_S1            | 34_K1*             |
| 25_X2               | 54_X1            | 34_K2*             |
| 25_K1*              | 54_K1*           | 35_X1              |
| 25_K2*              | 54_K2*           | 35_X2              |
| 26_S1               | 55_X1            | 35_K1*             |
| 26_X1               | 55_X2            | 35_K2*             |
| 26_X2               | 55_K1*           | 36_S1              |
| 26_K1*              | 55_K2*           | 36_X1              |
| 26_K2*              | 56_S1            | 36_X2              |
| DDA1**              | 56_X1            | 36_K1*             |
|                     | 56_X2            | 36_K2*             |
|                     | 56_K1*           | DDA1**             |
|                     | 56_K2*           |                    |
|                     | 53_X1            |                    |
|                     | 53_X2            |                    |
|                     | 53_K1            |                    |
|                     | 53_K2            |                    |
|                     | DDA1***          |                    |

\*Software currently processes 'K' as 'Ka', Radio Science does not use K-band (25.5 – 26.0 GHz), only Ka-band.

\*\*DDA1 is the downlink array subsystem, used occasionally by Radio Science. It will be replaced by DDA3 and DDA4 in middle of 2024 for dual array capability.

## 2.6 OLR Operation

Of the 8 OLRs per station, six operate in a connection (link-assigned) mode and two in a stand-alone mode. In the connection mode, the Network Monitor and Control (NMC) function receives monitor data from the OLR for displays at the NMC and provides a workstation from which the OLR can be operated. OLRs that are not assigned to a link are operated in a stand-alone mode without interference to any activities in process at the complex. Monitor data is not forwarded to the NMC by OLRs operating in the stand-alone mode.

The OLR employs a client-server architecture where each one acts as a server capable of accepting multiple connections from users operating the appropriate receiver client software at any time. In the link-assigned mode, one of these clients is the NMC workstation.

The OLR does not recognize any remote client as being superior to the others so it is up to the user to assign responsibility for control to one client with the other clients operating in a passive mode. NMC clients, on the other hand, have priority over remote clients and will terminate remote clients when brought up in a connection. Users who want to remotely monitor link-assigned OLR activities should bring up a remote client after it is put in the link.

All functions of the OLR may be performed from the OLR client in real time. Of special interest to the RS experimenter is the ability to adjust the predicted frequency profile, to slew the individual channel frequencies, to adjust FFT parameters, and to enable or disable recording for each channel.

## **2.7            *Data Delivery***

When recording is enabled, baseband samples and ancillary information, discussed below, are formatted into a file of one-second data records and stored on an OLR server for delivery via network playback to JPL or other users. A separate data file is created for each channel. Data delivery is via file transfer using Secure Shell (SSH) protocol. Data also may be obtained via Secure File Transfer Protocol (SFTP). The OLR is capable of playing data back in legacy 0159-Science format as well as 0222-Science format.

### **2.7.1            *Ancillary Data***

The following ancillary data are included as a header in each data record. A detailed description of the data is contained in DSN Document 820-013, module 0222-Science. The users will need to include the last two items in the filename for each channel to properly identify the supporting station, tracking pass, and spacecraft.

- Data record version
- Receiver configuration
- Channel identification
- Time tag for first sample in block
- Station and pass identification
- Spacecraft identification

## **2.8            *Performance***

The principal characteristics of the OLR are summarized in Table 3. In addition, radio science experiments are influenced by the overall stability of equipment at the stations. The following sections provide information on performance characterization in terms of frequency stability, phase noise, and amplitude stability for the ground stations.

Table 3. Open Loop Receiver Characteristics

| Parameter  | Value           | Remarks   |
|--|-----------------|---|
| Frequency Ranges Covered                         |                 |   |
| At OLR Input (MHz)                               | 100 - 600       |   |
| Referenced to S-band (MHz)                       | 2,085 – 2,609   | S-band downlink allocation is 2,200–2,290 MHz for near Earth application and 2,290–2,300 MHz for deep space applications    |
| Referenced to X-band (MHz)                       | 8,185 – 8,709   | X-band downlink allocation is 8,400–8,450 MHz for deep space application and 8,450–8,500 MHz for near Earth applications    |
| Referenced to Ka-band (MHz)                      | 31,785 – 32,309 | Ka-band downlink allocation is 31,800–32,300 MHz for deep space applications.   |
| IF Attenuation                                   |                 | Applied by IGC  |
| Range (dB)                                       | 0 – 31.75       |   |
| Resolution (dB)                                  | 0.25            |   |
| Doppler Compensation                             |                 |   |
| Maximum Doppler Shift (km/s)                     | 30              | At all downlink frequencies   |
| Maximum Doppler Rate (m/s <sup>2</sup> )         | 17              | At all downlink frequencies   |
| Maximum Doppler Acceleration (m/s <sup>3</sup> ) | 0.3             | At all downlink frequencies   |
| Maximum Tuning Error (Hz)                        | 0.5             | At all downlink frequencies   |
| Maximum Bitrate (Mb/sec)                         | 512             | Maximum recordable data rate per OLR with no performance degradation, assuming all 8 station OLRs are running at this rate. |

Table 3. OLR Characteristics (Continued)

| Parameter                       | Value           | Remarks                              |
|---------------------------------|-----------------|--------------------------------------|
| Baseband Resolution (MHz)       | 1               |                                      |
| Configurable Recording Channels | 16              | Available on each of the 8 OLRs      |
| Narrow Channel Tuning           |                 |                                      |
| Tuning (MHz)                    | ±262            |                                      |
| Resolution (Hz)                 | <1              |                                      |
| Recording Bandwidths            | 200 Hz – 50 MHz |                                      |
| Resolutions (bits/sample)       | 1,2,4,8,16      |                                      |
| Time Tagging                    |                 |                                      |
| Resolution (s)                  | 1               | Data is time tagged once per second  |
| Accuracy (μs)                   | 1               | With respect to station clock        |
| Signal Detection Display        |                 | 1 for each subchannel being recorded |
| Number of points in FFT         | 128 – 131,072   | Default is 1024                      |
| Spectra Averaging               | 1 – 1000        | Default is 10                        |
| FFT Interval (s)                | 1 – 10,000      | Default is 10                        |

### 2.8.1 *Frequency Stability*

DSN stations are designed to meet radio science requirements for stability. Frequency stability of the ground station is characterized by means of Allan deviation. RS System Performance Testing (SPT) has been conducted with the exciter, transmitter, the low noise amplifier (LNA), and the OLR receiving equipment. In this test configuration, an uplink signal generated by the exciter is frequency shifted via the test translator to a downlink frequency. The downlink signal is injected at the front-end of the LNA and passed through the RF-IF downconverter IGC and IFD which provides the IF signal to the OLR. SPT excludes instability in the frequency and timing equipment and the mechanical vibrations of the antenna. This is because frequency and timing instability is cancelled out, while the mechanical vibrations of the antenna are not included in the test configuration. Measurements of these items can be obtained via other means, making it possible to provide an estimate of the overall frequency stability for the stations.

Repeated SPT measurements have provided the basis of estimating the Allan deviation over a specified integration time for the ground station. Table 4 shows the 2-way Allan deviation numbers that any DSN ground station can achieve. These estimates include all elements in the ground station that constitutes the measurement path through which the OLR data are obtained. The values shown are meant to be the upper bound for performance (i.e., the not-to-exceed numbers). The measurements and analysis have accounted for the various station types (HEF, BWG, 70m), the different frequency band combinations (S, X, and Ka), and various system configurations.

### 2.8.2 *Phase Noise*

Phase stability (Spectral Purity) testing characterizes stability over very short integration times. The region of the frequency band where phase noise measurements are

performed can be as far as 10 kHz off the carrier frequency. Such measurements are reported in dB relative to the carrier (dBc), in a 1 Hz band at a specified distance from the carrier.

Phase noise data have also been captured as part of the SPT measurements. Table 5 shows the not-to-exceed phase noise levels for the different frequency bands, at specified offsets. As is the case with frequency stability testing, these numbers have been obtained through many repeated SPT measurements. They represent what the DSN can achieve under normal operation conditions.

### 2.8.3 *Amplitude Stability*

Amplitude stability tests measure the amplitude fluctuations produced by the open-loop receiving system relative to a constant (mean) amplitude input signal. The amplitude stability performance is specified in terms of a threshold on the amplitude fluctuations relative to the mean amplitude, and the corresponding probability that such fluctuations will not exceed such a threshold. Analyses with the collected data indicate that the 1-sigma number (67% of the time) of the amplitude stability at a given DSN station over a 30-minute observation at any frequency bands is less than 0.2 dB. This number includes the gain variation due to antenna pointing errors.

Table 4. Two-Way (Uplink and Downlink) Allan Deviation Estimates

| Averaging Time, s          | Allan Deviation       |                       |                       |                       |
|----------------------------|-----------------------|-----------------------|-----------------------|-----------------------|
|                            | 1                     | 10                    | 100                   | 1000                  |
| Station                    |                       |                       |                       |                       |
| 34-m HEF / 34-m BWG / 70-m | $7.0 \times 10^{-13}$ | $2.0 \times 10^{-13}$ | $3.0 \times 10^{-14}$ | $5.0 \times 10^{-15}$ |

Table 5. Uplink and Downlink Phase Noise Estimates

| Offset from Carrier, Hz      | Phase Noise, dBc-Hz |     |     |
|------------------------------|---------------------|-----|-----|
|                              | 1                   | 10  | 100 |
| Frequency Band               |                     |     |     |
| S-band (Uplink or Downlink)  | -63                 | -69 | -70 |
| X-band (Uplink or Downlink)  | -63                 | -69 | -70 |
| Ka-band (Uplink or Downlink) | -50                 | -55 | -57 |