



## Review Acknowledgment

---

Jeff Berner  
DSN Project Chief Engineer

Date

---

Mike Levesque  
Manager, 927 Service Management and  
Operations Office

Date

---

Robert Navarro/Felicia Sanders  
Manager, 922 TT&C End-to-End Data  
Services Office

Date

---

Belinda Arroyo  
Manager, 913 DSN Planning and  
Scheduling Office

Date

---

David Jacobs  
O&M Contract Mission Planning Manager

Date

## Document Change Log

Revision	Check (X) If Minor Revision	Issue Date	Affected Sections or Pages	Change Summary
-		04/18/12	All	Initial issue of document.
A	X	05/10/12	Appendix B.6	New section on DSN antenna pointing operations
B	X	06/22/12	Sections 3.4.2, 3.4.3, B.2.1	Update section on Maintenance Scheduling, add section on setup/teardown/handover times (3.4.2), add section on r/t schedule changes (B.2.1)
C	X	11/01/2012	Section 3.3  Appendix B.2.1	Update duration for long-range ephemeris from 28 weeks to 200 days Add new section on internet sources for r/t information on station status
D	X	08/21/13	Section 1.5 Section 3.3.1, 3.4 Section 3.8 Section 3.9.5.1 & 3.9.5.2 3.3	Update web site references Update Service Preparation Interfaces Update process for spacecraft emergency Update process for missions to submit simulation TLM data files Update duration for long-range ephemeris from 28 weeks to 548 days
E	X	03/20/14	Section 1.5 Section 3.3.2  Section 3.5.3  Section 3.9  Appendix C	Update references and web sites Add accuracy requirements for long range ephemeris Clarify scheduling constraint for transmitter limits Update to DSN-Mission Service Interface Validation Policies Add new appendix on Generic DSN Mission Service Interface Descriptions
F	X	07/22/14	Section 3.9  Section 3.10	Rewrite validation section to clarify mission responsibilities Reformat reviews section to change from bullets to text; add more detail
G	X	02/18/15	Cover page	Remove export control markings (not required) Add required CIT marking
H		06/2020	Cover Page Reviewers All Sections and App A and B Section 3.8	Changed names to current office managers  Section re-writes entire or minor changes and updates Added Section for ECC capabilities

## Table of Contents

<b>1</b>	<b>General Information .....</b>	<b>1-1</b>
1.1	Purpose.....	1-1
1.2	Applicability .....	1-2
1.3	Revision Control .....	1-2
1.4	Termination and Notation.....	1-2
1.5	References .....	1-2
<b>2</b>	<b>DSN Mission Services Overview .....</b>	<b>2-1</b>
2.1	DSN Mission Interface .....	2-1
2.2	DSN and Mission Responsibilities.....	2-1
<b>3</b>	<b>DSN Mission Service Policies .....</b>	<b>3-1</b>
3.1	Overview .....	3-1
3.2	Risk Activities .....	3-1
3.2.1	Assessment Process for DSN Support of Mission Critical Events.....	3-1
3.2.2	DSN Elevated Support Levels for Critical Event Activities .....	3-2
3.2.3	DSN Critical Event Analysis.....	3-3
3.2.4	Policy for Use of Redundant Assets for High Risk Activities .....	3-4
3.2.5	Policy for Scheduling High Risk Activities .....	3-4
3.2.6	DSN Maintenance Prior to Critical Events .....	3-4
3.3	DSN Service Preparation for Tracking Support.....	3-4
3.3.1	Overview .....	3-4
3.3.2	Service Preparation Subsystem (SPS).....	3-5
3.4	DSN Scheduling.....	3-7
3.5	DSN Usage Forecast .....	3-7
3.5.1	DSN Mission Scheduling Priority .....	3-8
3.5.2	DSN Maintenance Scheduling Priority.....	3-8
3.5.3	Track Setup, Teardown, and Uplink Handover Times.....	3-8
3.6	DSN and Mission Operations Interface.....	3-9
3.6.1	DSN Operations Efficiency Policy .....	3-9
3.7	DSN Timing for Initial Acquisition.....	3-9
3.7.1	DSN Initial Acquisition Commitment.....	3-10
3.7.2	Historical Experience .....	3-10
3.7.3	Sources of Delay.....	3-10
3.7.4	Potential Mitigations.....	3-12
3.8	Policy for usage of DSN Emergency Control Center (ECC) .....	3-12
3.9	Policy for Support of Spacecraft Emergencies.....	3-13
3.10	DSN-Mission Service Interface Validation.....	3-14
3.10.1	DSN Test Facilities .....	3-14
3.10.2	DSN-Mission RF Compatibility Tests.....	3-14
3.10.3	Station Data Flow Tests.....	3-16
3.10.4	Operational Readiness Tests .....	3-16
3.10.5	Project Interface Tests and Station Return-to-Service Demonstrations.....	3-16

3.10.6	Test Data Inputs.....	3-17
3.11	DSN-Mission Reviews .....	3-17
3.11.1	Mission Review of DSN Initial Acquisition Plan.....	3-18
3.11.2	Mission Review of DSN Risk Assessment for Critical Events.....	3-18
3.11.3	Mission Event Readiness Review (MERR).....	3-18
3.11.4	Level Two Status Review (L2SR) .....	3-18
3.11.5	Smallsat Readiness Review (SRR).....	3-18
3.12	DSN Discrepancy Reporting Process.....	3-18
<b>A.</b>	<b>Appendix A: Acronyms and Abbreviations .....</b>	<b>A-1</b>
<b>B.</b>	<b>Appendix B: DSN and Mission Real-Time Operations Interface .....</b>	<b>B-1</b>

## List of Figures

<b>Figure 3-1.</b>	<b>DSN Service Preparation Subsystem (SPS) .....</b>	<b>3-6</b>
<b>Figure B-2.</b>	<b>DSOC End-to-End Data Delivery Overview.....</b>	<b>B-2</b>

## List of Tables

<b>Table 1-1.</b>	<b>Controlling Documentation.....</b>	<b>1-2</b>
<b>Table 1-2.</b>	<b>Reference Documentation .....</b>	<b>1-2</b>
<b>Table 1-3.</b>	<b>DSN Services Web Sites .....</b>	<b>1-3</b>
<b>Table 3-1.</b>	<b>DSN Elevated Support Requirements.....</b>	<b>3-3</b>
<b>Table 3-2.</b>	<b>Standard DSN Setup/Teardown Times .....</b>	<b>3-9</b>
<b>Table 3-3.</b>	<b>Potential Causes for Delay (organized by effort on the ground).....</b>	<b>3-11</b>
<b>Table 3-4.</b>	<b>DSN RF Compatibility Tests .....</b>	<b>3-15</b>
<b>Table B-1.</b>	<b>DSN General Points of Contact for Mission Support.....</b>	<b>B-5</b>
<b>Table B-2.</b>	<b>DSN-Mission Points of Contact for Special Requests .....</b>	<b>B-5</b>

# 1 GENERAL INFORMATION

## 1.1 PURPOSE

The purpose of this Deep Space Network (DSN) Mission Service Interfaces, Policies and Practices (MSIPP) document is to establish basic policies and practices that are applicable to mission customers of the DSN, and to describe key DSN-Mission operations interfaces. The DSN is a multi-mission system that provides space communication services, i.e., acquisition and transport of tracking, telemetry, command, and science data over the space links. These data services have corresponding interfaces for mission users that enable the DSN to provide the required functions and deliver the data.

The scope of this document is to define the policies and standard practices associated with the operations and engineering of the mission interface for DSN services. These services include all activities carried out to support flight missions in all phases of the lifecycle, from the pre-launch design phases through the mission operations phases, and to support ground-based science programs using the DSN facilities as an observing instrument. Appendix B provides an overview of the DSN mission interface for real-time operations support. Appendix C provides an overview description of the generic DSN mission service interfaces.

The MSIPP is part of a set of documents that specify the DSN services and external interfaces and the associated mission-specific service agreements. The documents include:

DSN Service Catalog (DSN 820-100) - provides a comprehensive overview of the capabilities available from the DSN to support flight projects and experiment investigations. It also aids pre-project planning by providing information on how to obtain services and support from the DSN.

DSN Telecommunications Link Design Handbook (DSN 810-005) – provides a source of technical information useful in the design of spacecraft telecommunications equipment for mission customers. The information is intended to provide reasonable assurance to mission customers that their spacecraft telecommunications subsystem design will be compatible with the established or planned DSN configurations. Included are performance parameters of DSN equipment that supports the forward and return telecommunications link interfaces between spacecraft and the DSN.

DSN External Interface Specification (DSN 820-13 Series) – includes a set of documents that provide detailed definitions of external interfaces between the DSN and mission users. Included within the scope of interface definitions are data delivery protocols, communications definitions/assignments, data formats, data rate characteristics, and physical and electrical characteristics.

<Mission> DSN Service Agreement (DSA), (DSN 870-xxx Series) – documents the commitment for a specific mission to receive standard and custom data and support services from the DSN, including any request for cross-support services from non-DSN stations. The DSA commits the DSN to specific services for the duration identified in the agreement.

DSN-<Mission> Operations Interface Control Document (OICD), (DSN 875-xxx Series) - defines and controls the software and operational interfaces related to the provision of agreed services and the exchange of mission data between a mission and the DSN. The scope of a Mission OICD includes:

operational interfaces, data and product delivery interfaces, service management interfaces, and engineering support interactions. The OICD does not have an effective end date. During the mission lifetime, the specific interfaces that are utilized to implement the services may change. If changes are anticipated, the DSN will work with the mission to provide advance notice of the change and negotiate a transition plan.

## 1.2 APPLICABILITY

This MSIPP is applicable to all mission customers using the DSN to provide telemetry, tracking, command, and science services and other associated services identified by the DSA and documented in the OICD. This includes services provided at the DSN facilities or provided as cross-support services with other space agencies.

The responsibility of the DSN and the mission customer are to adhere to the interfaces, policies, and practices that are described in this document. The DSN services have been determined to be compatible with and support the standard interfaces and practices that are described in this document.

## 1.3 REVISION CONTROL

The control responsibilities for this document are assigned to the DSN Customer Interface Management Office and Management (CIMO) Program Office. This MSIPP adheres to the specifications and descriptions in the DSN controlling documents listed below. These controlling documents define and govern the mission services and telecommunications capabilities offered by the DSN in support of a mission. Major changes will require approval signatures. Minor changes may be implemented and distributed for notification.

**Table 1-1.** Controlling Documentation

Document Number	Rev/Date	Document Title
DSN Document 820-100	Latest	<i>DSN Services Catalog</i>
DSN Document 810-005	Latest	<i>DSN Telecommunications Link Design Handbook</i>

## 1.4 TERMINATION AND NOTATION

Abbreviations and acronyms used in this document are defined with the first textual use of the term. Appendix A contains a list of abbreviations, acronyms, and terms used in this document.

## 1.5 REFERENCES

The following reference documents and websites are applicable to the mission interface with the DSN.

### Documents

**Table 1-2.** Reference Documentation

Document Number	Document Title
DSN 820-13 Series	DSN External Software Interface Specifications

DSN 870-xxx Series	<Mission> DSN Service Agreement (DSA)
DSN 875-xxx Series	DSN-<Mission> Operations Interface Control Document (OICD)
DSN 810-043	Services, Functions and Capabilities Description for DSN Test Facilities (DTF-21, Mil-71, and CTT-22)
CCSDS Blue Book Specifications	CCSDS Recommended Standards (Blue Books)

### Web Sites

A number of DSN service websites require a mission user to obtain a JPL Lightweight Directory Access Protocol (LDAP) user account prior to access. In addition to a JPL/LDAP user account, access to some DSN service websites may require a JPL BrowserRAS account. The DSN will establish JPL/LDAP and BrowserRAS accounts (if necessary) for mission users that require access to the DSN websites. Once the user accounts are established, access to a specific site may require a site account.

**Table 1-3. DSN Services Web Sites**

Description	URL	Site Specific Account (in addition to LDAP)
DSN Telecommunications Link Handbook 810-005	<a href="https://deepspace.jpl.nasa.gov/about/commitments-office/mission-documents/">https://deepspace.jpl.nasa.gov/about/commitments-office/mission-documents/</a>	None
DSN Software Interface Specifications of external user interfaces (820-13 Series)	<a href="https://jaguar.jpl.nasa.gov/">https://jaguar.jpl.nasa.gov/</a>	JPL LDAP + DSN request
Service Preparation Subsystem (SPS) Portal	<a href="https://spsweb.ftops.jpl.nasa.gov/">https://spsweb.ftops.jpl.nasa.gov/</a>	JPL LDAP + Authorization Request Form on SPS Portal
DSN Tracking Data Display	<a href="https://trkweb1.jpl.nasa.gov/">https://trkweb1.jpl.nasa.gov/</a>	JPL LDAP + BrowserRas
DSN Scheduling Wiki	<a href="https://wiki.jpl.nasa.gov/display/plansched/DSN+Scheduling+Wiki">https://wiki.jpl.nasa.gov/display/plansched/DSN+Scheduling+Wiki</a>	JPL LDAP + Email request to spo_admin@jpl.nasa.gov
DSN Tracking and Navigation Data File Server	OSCARX	JPL LDAP + User Account, SecurID required for some access*
Discrepancy Reporting System (DRMS)	<a href="https://cmmaster.jpl.nasa.gov/dr/">https://cmmaster.jpl.nasa.gov/dr/</a>	JPL LDAP + DSN request
DSN User Loading Profiles and Major Events Files	<a href="https://rapweb.jpl.nasa.gov/reqs.html">https://rapweb.jpl.nasa.gov/reqs.html</a>	JPL LDAP
DSN Status on Failed Station Equipment	<a href="https://cmmaster.jpl.nasa.gov/dr/esb.asp">https://cmmaster.jpl.nasa.gov/dr/esb.asp</a>	JPL LDAP
JPL Large File Transfer (LFT)	<a href="https://lft.jpl.nasa.gov/">https://lft.jpl.nasa.gov/</a>	None
CCSDS Blue Book Specifications	<a href="https://public.ccsds.org/publications/BlueBooks.aspx">https://public.ccsds.org/publications/BlueBooks.aspx</a>	None
CCSDS Silver Book Specifications (SLE)	<a href="https://public.ccsds.org/Publications/SilverBooks.aspx">https://public.ccsds.org/Publications/SilverBooks.aspx</a>	None

For missions using DSN network services, it is required that a NASA/DSN Spacecraft ID (SCID) be established for the spacecraft. The DSN uses the decimal value of the SCID for identifying the spacecraft on the ground.

In addition, the Consultative Committee for Space Data Systems (CCSDS) assigns a unique spacecraft transponder ID, which is referred to as the Global SCID (GSCID). The GSCID assignments are available online at <http://public.ccsds.org/SpacecraftID.aspx>. The GSCID is the concatenation of the 2-bit Version Number (VN) and the (8-10 bit) Spacecraft Identifier (SCID) = GSCID = VN • SCID



Note that the SCID value in the GSCID and the DSN SCID are not necessarily identical. The latest listing of DSN SCID is contained in the DSN 820-13 Document, OPS-6-21-4 Spacecraft Code Assignments.

## **2 DSN MISSION SERVICES OVERVIEW**

### **2.1 DSN MISSION INTERFACE**

The Customer Interface Management Office (CIMO) consists of three offices which oversee the life cycle of mission interfaces. Office 911 Strategic Partnerships and Customer Formulation which works with foreign and commercial partners seeking to utilize DSN services, Office 912, Mission Support Definition and Commitments Office manages the planning and development of the mission interface, and Office 913, DSN Planning and Scheduling, owns the scheduling and provision process of DSN services to space and science missions throughout the entire life cycle. The DSN Project Office manages and is responsible for the DSN, including system/service requirements and design, subsystem products development, operations, and maintenance.

Office 912 assigns a Mission Interface Manager (MIM) to act as the DSN service provider representative and to interface with customers from early planning through design, development, testing, flight operations, and closeout. The MIM is responsible for ensuring the provision of DSN operations support for a mission and for representing the mission to the DSN to assure a continued understanding of the mission's requirements, concerns, system performance, etc. As well, the MIM is responsible for representing the DSN to the project to ensure the project understands and is made of future evolution of DSN services and capabilities. Office 911 arranges for support services from non-NASA networks as required. In addition, the DSN Operations and Engineering contractor (O&M) assigns a Network Operations Project Engineer (NOPE) while Office 922, TT&C End to End Data Services (TTC) assigns a Project Data System Engineer (PDSE) to work with each mission.

### **2.2 DSN AND MISSION RESPONSIBILITIES**

The responsibilities of the DSN are to provide the telemetry, tracking, command, and science services (and other associated services identified by the Mission DSA) using space and earth link telecommunications capabilities either at the DSN facilities or by arranging support services with foreign or commercial space agencies.

The mission provides information about the spacecraft and mission design as necessary for Office 912 to provide the committed services and will participate in activities that are necessary to validate the service interface prior to the operational commitment.

If necessary to meet mission requirements, the DSN arranges foreign or commercial network services for NASA deep space missions with other space agencies or tracking networks. The responsibilities of the mission customer are to provide mission operations plans, technical details, and operational parameters related to the required services and telecommunications capabilities.

Throughout the mission lifetime, the mission and DSN personnel participate in joint planning meetings and a DSN representative presents at mission reviews as required or requested.

During the development phase, the mission and the DSN participate in a series of verification and validation activities with the support of all appropriate resources. Although the DSN participates in and supports the validation of the end-to-end, space-ground data accountability (uplink and downlink), the mission is ultimately responsible for that validation since the DSN cannot confirm that

the commands received by the spacecraft are correct in content nor that the data extracted by the mission from the DSN interface is the expected content.

## **3 DSN MISSION SERVICE POLICIES**

### **3.1 OVERVIEW**

This section establishes basic policies that will be applicable in the preparation, validation, and execution of the operational interfaces between the DSN and its mission customers in support of committed DSN services for a mission.

### **3.2 RISK ACTIVITIES**

#### **3.2.1 ASSESSMENT PROCESS FOR DSN SUPPORT OF MISSION CRITICAL EVENTS**

Notification of major mission events and special tracking conditions which may pose significant risk to a mission shall be communicated by the Mission Manager to the MIM with sufficient lead time so that appropriate planning and staffing adjustments can be made.

The DSN performs a risk assessment for tracking support of major mission events that may pose significant risk to a mission's success or to the DSN's ability to provide committed services. The DSN policy will be to evaluate each event based on likelihood of DSN failure and consequence to the mission. This review process will occur for each critical event and it will not be assumed to apply for all future events of a given type. As DSN reliability improves and the station gains experience with a given mission, the risks and associated support level will be updated to reflect the likelihood of failure at the station.

If the assessment concludes that there is a significant risk based on the likelihood of ground failures and associated consequences to the mission, then additional risk mitigation strategies are implemented. The DSN options include elevated support levels and the use of redundant assets as required to lower risk to acceptable levels.

The risk assessment is based on the likelihood and consequence of failures associated with a specific DSN tracking pass. The responsibilities for setting the likelihood and consequence values are defined in the following sections.

##### **3.2.1.1 Likelihood of Occurrence (DSN failure to provide services)**

Likelihood of Occurrence is the estimated probability that DSN will fail to deliver committed services as required during a tracking support. The likelihood may include consideration of several factors, such as the complexity or uniqueness of the support (such as first time use of new capabilities), uncertainty in mission sequence of events, need for technical assistance during the event, use of non-standard services, limited equipment availability for a critical event, lack of redundant assets, and other factors which increase likelihood of a ground system anomaly.

##### **3.2.1.2 Consequence of Occurrence (Impact to mission in the event of a service failure)**

Consequence of Occurrence is the estimated severity of the consequences that will be realized by the mission if there is a failure to provide committed data services during a tracking pass.

### 3.2.2 DSN ELEVATED SUPPORT LEVELS FOR CRITICAL EVENT ACTIVITIES

When a mission notifies the DSN about a high-risk event, the MIM coordinates with the mission to evaluate the support requirements and impact of the event on the mission. The MIM and NOPE assess the need for risk mitigation, including use of elevated support levels and redundant assets to ensure committed data services are provided as required. In some cases, the support level may be increased or decreased depending on the availability of redundant assets.

The DSN provides tracking support at one of four “support levels.” As described, the decision on the need for elevated support for a given pass is the responsibility of the DSN. The nominal support level is defined as Level-4 (L4). A Level-1 (L1) support is provided when the highest possible degree of ground system reliability is required. This may include a launch, landing, or orbit insertion, where a ground data system failure would jeopardize the safety of the spacecraft and potentially end the mission. Missions must provide one-year notification to the MIM for any mission-critical event, which may require elevated support at the highest levels (L1 or L2).

The process includes the following activities, summarized in **Table 3-1**:

1. For a mission critical event, the mission will provide a description of the event, spacecraft configuration, timeline of spacecraft and ground activities planned, uncertainty in sequence of events, success criteria, and an evaluation of the consequence to the mission if a tracking pass is not successful. The DSN will evaluate the likelihood of network failures to data service commitments, based on the uniqueness and complexity of the event. For L3 elevated support, the decision will be made jointly by the MIM and the NOPE with concurrence by Office 927 Service Management and Operations. For L1 or L2 supports, the decision will require concurrence of the DSN Project Office.
2. For both L1 and L2 events, a formal risk assessment review to review the mission risks and DSN support plans is held jointly with the mission and a DSN Review Board for: 1) Mission Event Readiness Review (MERR), 2) Level 2 Status Review (L2SR), or 3) Smallsat Readiness Review (SRR). All reviews are to held at least 30 days prior to the major event. An L3 support may include an informal DSN-Mission Status Review, at the discretion of the MIM and NOPE. The purpose of a DSN-Mission review is to assess the operational readiness of the DSN for a critical mission event. The MIM is the responsible individual for conducting these reviews. For an MERR, L2SR, or SRR the convening authority is the DSN Project Manager.
3. For L1 and L2 supports, a Briefing Message will be issued by the NOPE at least 5 days prior to the event. For L3 supports, a Briefing Message will be issued 3 days prior to the event. A Briefing Message for a L4 support is issued if notification of special activities is important for network operations.
4. The following DSN support activities are required for elevated support levels, as indicated by an X for each designated Level. For events designated as “(X)”, the requirement is at the discretion of the MIM and NOPE.

**Table 3-1. DSN Elevated Support Requirements**

<b>Support Level Requirements</b>	<b>L1</b>	<b>L2</b>	<b>L3</b>	<b>L4</b>
Mission Overview of Event, associated risks related to ground failures, Spacecraft Configuration and Timeline of Flight and Ground Events	x	x	x	
DSN Participation in Mission ORTs	x	x		
NOPE Briefing Message with Critical Event Advisory to Network	x	x	x	(x)
DSN Technical Advisor for Real-Time Support	x	x	x	
DSN Real-Time Operations Teams available	x	x	x	x
DSN JPL Subsystem Engineers (on site or on call)	x	x		
DSN Critical Event Planning	x	x	(x)	
DSN Network Configuration Control	x	x		
DSN-Mission joint Risk Assessment	x	(x)		
DSN Mission Event Readiness Review (MERR)	x			
DSN Mission Event Level 2 Status Review (L2SR)		x		
DSN Mission Smallsat Status Review		x	x	
DSN Redundant Assets (L1 required, L2 advised, L3 requires approval)	x	x	(x)	

### **3.2.3 DSN CRITICAL EVENT ANALYSIS**

For DSN readiness/status reviews associated with L1 or L2 supports, a DSN Critical Event Plan is generated. The plan contains specific strategic and tactical aspects of tracking operations that are not routine.

In addition to the spacecraft telecom information provided in the DSN-Mission OICD, the following is the list of information needed to perform a critical event analysis. All information should be supplied to the DSN no later than 90 days prior to the event:

1. Ephemeris files or vectors for the nominal and +/-3 sigma dispersion trajectories (Launch Case)
2. Ephemeris files that would include burn/no burn cases of critical maneuvers, such as orbit insertions, deep space maneuvers, flyby trajectories, and Entry, Descent, Landing (EDL) trajectories
3. Launch opportunities (Launch case)
4. Spacecraft receiver max input power level (nominal and emergency commanding)
5. Stability of frequency standard (USO [ultrastable oscillator], AUX OSC [auxiliary oscillator], etc.). This could include frequency vs. temperature plots and/or Allen deviation, if available, or boundary limits for the expected frequency.
6. Spacecraft configuration and sequence of events, including spacecraft and ground events
7. Ground track including any dependency on event times
8. Antenna gain patterns (supplied as gain vs. angle-off-boresight), including Right Ascension (RA) and Declination (DEC) of the antenna boresight axis. If multiple antennas are used during initial acquisition, specify RA/DEC for each boresight axis.

9. Contingency plans, including spacecraft configuration and trajectory information for cases such as parking orbits, unsuccessful burns, or any event that results in an unknown trajectory.

The following analysis is presented by the DSN Critical Event Planner (CEP) at DSN readiness reviews:

- Ground Tracks and Stereo Plots
- Maximum Tracking Observables and Capabilities
- Observables (open, mid, and close cases of the launch window)
- Downlink conditions (Signal level, Doppler, Doppler Rate, Doppler Acceleration Profiles)
- Uplink Conditions (Signal Level, Sweep Profile, Uplink Frequency Profiles)
- Azimuth/Elevation Rates

### **3.2.4 POLICY FOR USE OF REDUNDANT ASSETS FOR HIGH RISK ACTIVITIES**

The decision on the use of redundant assets, including antennas or global equipment (such as backup receivers), is the responsibility of the DSN, based on the risk assessment process defined in Section 3.2.1.

The use of redundant assets is usually required to mitigate risk for the highest support levels, L1 and L2. For L3 supports, there may be special cases in which redundant assets are required to mitigate risk. These cases must be assessed and approved by the MIM and NOPE. Redundant assets are not to be scheduled for tracking passes at the lowest criticality level L4.

### **3.2.5 POLICY FOR SCHEDULING HIGH RISK ACTIVITIES**

If the DSN has committed to an elevated level of support and/or agreed to the use of redundant assets for a high risk event, the mission is responsible for negotiating the required tracks to support the event. If redundant assets are not available, then the DSN and the mission must work together to reach agreement on the risks involved in supporting the event and to identify other risk mitigation strategies if possible.

### **3.2.6 DSN MAINTENANCE PRIOR TO CRITICAL EVENTS**

When a L1 critical event is being planned, the DSN may direct that a maintenance plan be generated and that special maintenance activities be conducted prior to the event. The plan will include identifying critical spares and maintenance that can be performed in advance to ensure the reliability and availability of particular DSN assets, which will be supporting that event.

## **3.3 DSN SERVICE PREPARATION FOR TRACKING SUPPORT**

### **3.3.1 OVERVIEW**

DSN tracking services are requested and controlled via a unified service management interface. This includes the allocation and scheduling of DSN resources and assets during the planning phase, configuring the assets during the preparation phase, executing operations in real-time, and assessing performance after the pass.

The service management phases include:

- 1) Service Planning
  - a) Develop mission service agreement and plans, generate long-range forecast and mid-range tracking schedules
- 2) Service Preparation
  - a) Generate mission viewperiods, DSN tracking schedules, DSN sequence of events, and support data products (including antenna and telemetry predicts)
- 3) Service Execution (real-time, setup=30-60 min prior to track)
  - a) Assign Deep Space Communications Complex (DSCC) equipment to a link, configure the equipment, and perform needed calibrations prior to the beginning of the track.
  - b) Execute the scheduled TTC services and deliver data to the mission customer. For tracks in support of the data acquisition service, this includes the execution of the track and delivery of the data to the mission customer. For tracks in support of the experiment access service, the execution is the responsibility of the authorized experiment access team.
- 4) Service Assessment
  - a) Post track data analysis to determine the quality of the services provided.

### **3.3.2 SERVICE PREPARATION SUBSYSTEM (SPS)**

The Service Preparation Subsystem (SPS) is the software interface for the planning and preparation of DSN tracking support for mission customers. The SPS includes a web portal and data repository for support products and an interface for DSN resource scheduling.

The SPS web portal, <https://spsweb.fltops.jpl.nasa.gov>, provides a single point of access for all service preparation related exchanges between the DSN and its customers. After a mission user has obtained a JPL LDAP user account, an SPS User Account can be established by filling out an SPS User Authorization Request Form, which is available on the SPS portal home page. Any mission user that will be uploading mission files to the SPS must indicate a “role” on the request form. The portal is the single point of entry for the delivery of input from the customer, including ephemeris files and mission sequence of events for the pass (i.e., via Nominal Sequence of Events (NSOE) or DSN Keyword Files (DKF)). The DSN NOPE also delivers mission-specific station configuration files to the SPS, based on the information that the mission provides in the OICD.

Using the mission input files and DSN configuration tables, the SPS will produce a Support Data Package (SDP) for each scheduled track. The SDP includes antenna pointing and telemetry predicts files and a Pass Sequence of Events (PSOE), which is a timeline of events during the pass. These files are used by DSN to automate pass operations, avoiding need for manual intervention by the station link controller. All such products can be viewed and retrieved from the SPS portal, with about six months of historical data online.



The SPS portal provides the following products applicable to the mission interface:

- DSN tracking schedules (7-day schedule files or custom files via SPS queries)
- View Period files containing information on spacecraft visibility with DSN stations
- SDP files including PSOE files used to automate station operations
- DSN Mission-specific station configuration files
- Mission ephemeris and Mission NSOE/DKF files

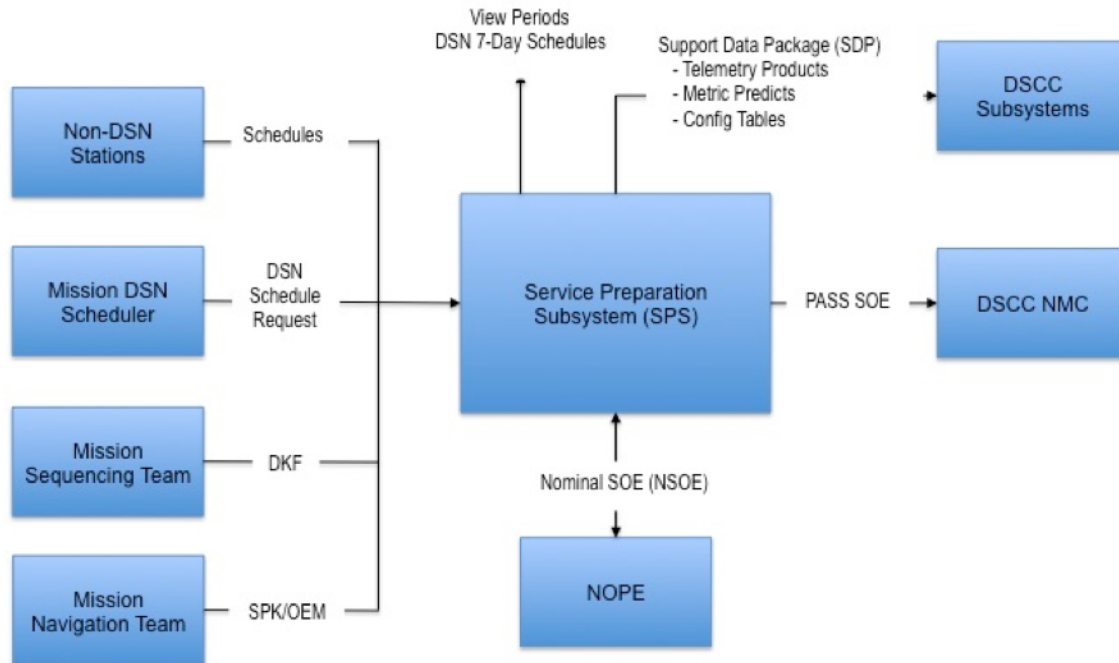

**Figure 3-1.** DSN Service Preparation Subsystem (SPS)

A mission will deliver two types of ephemeris files to the SPS portal:

- Long-range “scheduling grade” ephemerides (at least 548 days (18 months) in span) must be maintained on the portal at all times. These long-range files are used for View Period File Generation and for DSN Scheduling. They should be delivered at least every 6 months or more frequently as required for accurate scheduling. The scheduling grade ephemerides are required to be accurate to 300 seconds for the first 6 months and can be representative for the last 12 months.
- Short-range “predicts-grade” ephemerides (at least 3 days in duration, but with no specified maximum duration). These are used in the generation of the Support Data Package (SDP) that is delivered to the station to provide information about the spacecraft trajectory during the pass. Ephemeris files can be submitted at any time. It is not necessary to deliver a separate file for each track. The frequency of delivery for predict-grade files is at the discretion of the mission. The trajectory predictions must be sufficient to enable the DSN to successfully execute any tracks for which the latest delivered file is utilized. The SPS system will

automatically use the latest available, predict-grade ephemeris file on the portal for generating station predicts.

A baseline version of the predict-grade ephemeris files and DKF files (if applicable) must be delivered to the SPS portal prior to the predict generation time specified in the Mission OICD (typically 3-5 days prior to the beginning of activity (BOA) defined for the track). If updates to the baseline files are delivered more than one hour prior to the BOA for a track, the SPS will automatically re-generate the predicts for the pass. In the event that the mission must change the trajectory less than one hour prior to the track, the mission will deliver the files and notify the Ops Chief of the change.

### 3.4 DSN SCHEDULING

The DSN Scheduling Wiki (aka “Planning and Scheduling Space”) is located at:

<https://wiki.jpl.nasa.gov/display/plansched/DSN+Scheduling+Wiki>

The Wiki includes DSN schedule status, policies and processes, and access to scheduling tools for mission users. After obtaining a JPL user account, a mission user can request access to the DSN Scheduling Wiki by sending an email to [spo\\_admin@jpl.nasa.gov](mailto:spo_admin@jpl.nasa.gov)

For schedule requests, the mission’s scheduling representative submits the requests to the DSN Service Scheduling Software (SSS). Schedule requests conform to the DSN 820-13, OPS-6-12 document. The pass Beginning of Track (BOT) time for uplink passes is nominally based on transmitter limits (~10 degree elevation).

For mission change requests to a negotiated (“conflict-free”) schedule, the contact is as follows:

1. Contact the project scheduling representative for non-real-time changes. The scheduler will coordinate, work any conflicts with other projects, and submit changes to the schedule as requested.
2. Contact the DSN Operations Chief for real-time changes. Real-time equals current time plus 4 hours. The Ops Chief will submit and push changes to the schedule if “conflict-free”. Priority scheduling is given during spacecraft emergencies only. The Ops Chief may work conflicts with other projects in order to keep a “conflict-free” schedule. During off hours, projects that utilize lights-out operations may not be able to be moved to another DSN resource. The Ops Chief will provide contact information to users if needed for negotiation.
3. The scheduler will coordinate and submit changes to the schedule as requested.

### 3.5 DSN USAGE FORECAST

The mission is responsible for providing an up-to-date DSN User Loading Profile (ULP), along with an associated Major Events file, that describes expected tracking support requests for nominal operations throughout the mission. The ULP is described in the DSN 820-13, 0221-ServMgmt, “User Loading Profile (ULP) and Event Data File for DSN Scheduling and Forecasting.” The ULP must be signed by the mission manager and faxed to 626-305-6389. Electronic copies of the ULP and Events File are to be sent to: [DSN-ULP@jpl.nasa.gov](mailto:DSN-ULP@jpl.nasa.gov). The MIM should be contacted if a new service is requested or if there are significant changes in the tracking profile. The Mission ULP and Major Events

files can be obtained from the RAPWEB site at: <http://rapweb.jpl.nasa.gov/reqs.html>. There is a future plan to improve the long-range forecasting processes and associated products such as the ULP.

### **3.5.1 DSN MISSION SCHEDULING PRIORITY**

The scheduling of DSN resources is based on mission requirements and a peer-to-peer negotiation process for resolving schedule conflicts. The support level designation for a pass will not be used to obtain higher priority for securing DSN support in the Resource Planning and Scheduling process. A “schedule request priority” value is defined by the mission for each schedule request, but it is based on a different set of criteria and is not necessarily tied to the support level for a track.

### **3.5.2 DSN MAINTENANCE SCHEDULING PRIORITY**

The DSN Project is responsible for operations and maintenance of DSN assets. These assets represent a large capital investment, which are not easily replaced and, if not properly maintained, can degrade in performance and sustain serious failures.

Every DSN antenna requires recurring weekly preventive maintenance. Because this maintenance time represents the minimum time required to perform specific tasks, it will not normally be relinquished without being replaced by another equal length block of time in the same week. During high-activity periods surrounding critical events, it may not be possible to schedule maintenance on an antenna during a given week. Under these circumstances, DSN scheduling will coordinate for additional time in an adjacent week, if possible, to ensure that maintenance is scheduled within a reasonable time around the high-activity period. During execution of the 7-Day Operations schedule, DSN maintenance shall have a higher priority than nominal tracking activities, and other users requesting tracking passes are expected to appreciate the importance of maintenance time to help ensure high reliability of DSN antennas and to minimize the risk of unscheduled failures. Real-time schedule requests to delete DSN maintenance shall be made through the DSN Ops Chief, and will only be allowed on an occasional basis with the DSCC Director’s, or their representative’s, approval.

### **3.5.3 TRACK SETUP, TEARDOWN, AND UPLINK HANDOVER TIMES**

Standard setup times for tracking activities consists of a nominal time for a station to be configured for standard telemetry, command, and tracking data services, plus additional time for special services, e.g., ranging, high-power radiation, radio science, arraying, or multiple spacecraft per antenna (MSPA). The standard times are based on the DSN’s demonstrated ability to reliably assemble and validate the readiness of each support configuration. The standard post-track period is the minimum time required for tearing down the previous configuration. Table 3-2 shows the standard DSN Setup/Teardown Times to be used for scheduling purposes. Any proposed changes to these times must be approved by the DSN. Exceptions to standard times are documented in the DSN-Mission OICD.

When a mission is planning an uplink handover between two DSN stations, DSN operations nominally requires at least a 10-minute overlap in the incoming and outgoing station’s uplink windows. The incoming station can begin uplink radiation 5 minutes after the beginning of track (BOT), as long as the radiation limits have been cleared. Deviations from this convention for mission-critical events will be coordinated by the NOPE. When a mission is planning an uplink that does not include a handover, the uplink radiation can be planned any time after radiation limits have been cleared at that station and it is at least 5 minutes after BOT.

**Table 3-2.** Standard DSN Setup/Teardown Times

Track Function	Basic Setup Time (min)	Additional Time (min)	Basic Teardown Time (min)
Standard Track (Uplink with command but without ranging)	45		15
High Power Transmitter (70m)		15	
Ranging		15	
MSPA Support	75		15
2nd or 3rd MSPA Support	30		15
2nd or 3rd MSPA Support uplink/dual downlinks (s-band/x-band)	30		
Ka-band Monopulse Support		30	
Very Long Baseline Interferometry (VLBI)	90		30
Station Array		15	
DDOR or Downlink ONLY Support	30		15
Radio Astronomy (70m)	45		30
Goldstone Solar System Radar X-Band	90		30
Goldstone Solar System Radar S-Band	90		45
Bi-Static Radar Measure (70m)	120		60
Clock Sync	90		30
Maintenance	0		0

### 3.6 DSN AND MISSION OPERATIONS INTERFACE

The MSIPP Appendix B provides an overview of the mission interface with DSN for real-time tracking operations.

#### 3.6.1 DSN OPERATIONS EFFICIENCY POLICY

To support an expanding DSN network, DSN requires maximum operations efficiency during real-time tracking operations. This includes assigning multiple links to one controller, automating pass operations, reducing real-time voice communication with the link controller, and minimizing manual intervention. The real-time mission operations concept should be in alignment with this DSN operations efficiency policy. In addition, the mission sequence of events interface (either 0211 DKF or NSOE) is expected to fully describe the pass configuration and a DKF would be required if there are any dynamic changes during the pass. If there are changes from the predicted sequence of events or if the pass is identified as an elevated support level L1-L3, the mission is required to be present for a pre-pass briefing at BOA or as directed by the NOPE for a critical event. The mission should provide a single point of contact on the VOCA (Voice Output Communication Aid) interface for real-time exchanges.

### 3.7 DSN TIMING FOR INITIAL ACQUISITION

Initial acquisition refers to the first acquisition of a spacecraft by a DSN station following launch. This section is intended for use by missions to understand the generic DSN initial acquisition timing commitment for use in the mission planning.

### 3.7.1 DSN INITIAL ACQUISITION COMMITMENT

The DSN commitment is to acquire carrier and telemetry within 10 minutes of predicted acquisition of signal (assuming adequate link budget, stable spacecraft signal, and appropriate bit rate and frame lengths so that telemetry acquisition is not significantly delayed beyond carrier acquisition). Of course, this is not a guarantee of acquisition but is provided as the duration that the DSN recommends that missions use for planning purposes. Also, during the actual acquisition, the DSN will generally limit reporting information to a mission, and will request that a mission not request status updates, during this interval, prior to acquisition. This will allow the DSN to focus on analyzing the available information and work any potential problems with limited distractions (except, of course, where communication with the mission may facilitate the resolution).

**Note:** *If the spacecraft transmits a significantly suppressed carrier at the time of initial acquisition (suppressed to the point that residual carrier cannot be used), the time assumptions discussed in this document are not valid, and a larger acquisition time should be expected (although many of the additional causes for delay may still be applicable).*

### 3.7.2 HISTORICAL EXPERIENCE

The DSN can generally achieve acquisition within one minute under nominal conditions.

Ten minutes is sufficient for the DSN to recognize most of the common types of problems, make a decision on how best to proceed, and implement the response. In most cases, actually implementing the response is a relatively rapid process (on the order of seconds to one-to-two minutes). The majority of the time is spent in recognizing which of the many factors is the source of the lack of acquisition and selecting the best response.

A statistical analysis of the DSN's initial acquisition is not planned since it is not clear that results of the analysis would be meaningful. Given the diversity in the spacecraft (spinning or not, different frequency bands, different launch phase timelines, etc.), and the change of DSN equipment through the launches and through the years (different complexes, different stations used at each complex, new/modified equipment and DSN procedures), it is believed that further quantifying or characterizing the response within the one to ten minute range could be misleading. Instead, the DSN is providing information about the most common causes of delays in order to allow individual missions to evaluate their plans to determine how many of those factors may be applicable or are mitigated. Also, for any individual problem, narrowing the response time to less than ten minutes could be unrealistic even if a shorter response was demonstrated in specific instances.

### 3.7.3 SOURCES OF DELAY

The following conditions represent the most common causes of delay or causes that should be considered as possible even if unlikely in any analysis of the timeline for the acquisition of either telemetry or carrier. Generally, if carrier acquisition is achieved, telemetry acquisition will follow at a relatively deterministic time based on the bit rate, frame length, and encoding scheme; however, low signal levels can interfere with maintaining telemetry lock even if carrier lock is maintained.

The mitigations indicated in this table have a broad range of effects from eliminating or significantly reducing the likelihood of the problem occurring to simply making the DSN aware of the possibility of the condition as a mechanism for enabling a more rapid recognition of the source and therefore leading to a faster decision on the appropriate response.

**Table 3-3.** Potential Causes for Delay (organized by effort on the ground)

Cause	Comment	Mitigation
Excessive frame length coupled with low bit rate	Will cause "slow" telemetry acquisition but the delay is deterministic if lock can be achieved. DSN requires 3-4 frames before achieving telemetry lock	Short frame length/reasonable bit rates
Low (or no) signal level		
Transponder not performing as expected	Spacecraft anomaly	Be aware of possible symptoms
Mis-pointed spacecraft antenna	Spacecraft anomaly, launch release dispersion	Plan for possible ranges
Spacecraft trajectory error		Search strategy, acquisition aid
Reverse polarization		Be aware of possible ranges of signal level
Nulls in the antenna pattern		
Spinning that affects the signal		Be aware of possible effects
Spacecraft detumble timeline		
Mis-pointed ground antenna	Operator error (trajectory dispersion covered elsewhere). Note that a mis-pointed ground antenna as a result of operator error has not been experienced in recent memory	Training, procedures for trajectory deliveries
Spacecraft not in expected configuration (e.g., safe mode versus nominal)		Separate antennas and/or downlink channels configured (limits redundancy)
Spacecraft transponder temperature beyond expected range	May be caused by transponder warming up	Turn on transponder before BOT
Spacecraft trajectory rates so large that the ground antennas cannot keep up		Separate antennas (limits redundancy)
Ground (DSN) error		Training and familiarization with the launch timeline and spacecraft configuration(s)

Use of the X-band acquisition aid can increase the robustness of acquisition; however, there are limitations. The signal threshold for the acquisition aid is much higher than for the primary antennas. Thus, while the acquisition aid can be helpful in the event of trajectory dispersions, such dispersions will also generally significantly reduce the received signal level. Additionally, due to spacecraft antenna angles relative to the ground, there can be multipath reflections off of the spacecraft of the opposite signal polarization that can affect the acquisition aid signal reception. This can result in a signal level that is below the detection threshold for the acquisition aid.

Open-Loop Receivers (OLR) are used by the DSN for launch support, but they are primarily useful for forensics and not for real-time support – the primary antennas have sufficient information to enable them to find the signal.

### 3.7.3.1 Most Common Cause of Delays

The following represent the most common causes of delays in the acquisition of carrier or telemetry, generally in order that the first is the most common event:

- Pointing of the ground antenna and determining if moving the primary antenna is the appropriate response (regardless of the source – trajectory dispersion, ground error, etc.).
- Spacecraft pointing not as expected.
- Poor knowledge of the antenna patterns (patterns are frequently not measured after the antenna is installed on the spacecraft and, therefore, do not account for interference with other hardware).

### **3.7.4 POTENTIAL MITIGATIONS**

The following factors for the spacecraft and launch phase timeline can help to mitigate the potential for delays in acquisition:

- Short frame length/higher bit rates.
- Transponder Ranging Channel turned off to reduce the noise floor on the downlink
- Spacecraft not spinning or spinning in a way that is not significant to the received signal level
- Small trajectory dispersions.
- Transponder fully stable at beginning of track (sufficient warm-up time).
- Stable frequency that is well characterized for the expected thermal conditions
- DSN familiarity with the timeline and spacecraft configuration(s) (including off-nominal possibilities).
- Good coordination/plans for trajectory deliveries (especially in the case of trajectory slips – DSN practice is to not stage the predicts at the stations until the slip has actually occurred to prevent the wrong predict being used accidentally – also have SPS experts on-hand to facilitate the generation of new predicts, if necessary).

### **3.8 POLICY FOR USAGE OF DSN EMERGENCY CONTROL CENTER (ECC)**

The DSN Emergency Control Center (ECC) is a key DSN Continuity of Operations (COOP) facility. In accordance with the JPL DSN COOP plan, 841-004, the ECC will be activated in the event of the loss of the Deep Space Operations Center (DSOC) facility and its key service management support services.

The ECC provides only a limited set of the DSOC support services, documented in the [810-007-203, ECC Capabilities and Service Support](#) document. ECC provided support services are designed to enable subscribing missions to maintain spacecraft health and safety in a COOP event. The ECC support service profile is to provide key Telemetry Tracking & Command (TT&C) data services to the mission's Mission Operations Center (MOC) via remote connectivity from the MOC to the ECC in the event of the loss or unavailability of the Deep Space Operations Center (DSOC) located in the Space Flight Operations Facility (SFOF) within the Jet Propulsion Laboratory (JPL) Building 230.

Missions requiring ECC services shall document their required ECC services in the mission DSA and OICD. Upon ECC activation, subscribing missions will utilize ECC services in accordance with their OICD/DSA.

### **3.9 POLICY FOR SUPPORT OF SPACECRAFT EMERGENCIES**

The following policy statement governs spacecraft emergency support by DSN operational resources. These resources include, but are not limited to, DSN antennas, data systems, and operations personnel.

A spacecraft emergency, with the exception of Class D missions, is defined as any anomaly or onboard condition that requires immediate and unrestricted access to DSN resources in order to prevent complete and imminent failure of a mission.

In the event of a Class D mission spacecraft emergency concurrence for use of allocated assets must be obtained by the corresponding projects.

Each Project Manager (or designee) is responsible for establishing the technical and operational criteria for determining spacecraft emergencies, and is the single point of authority for declaring that an emergency exists. Each project shall maintain and provide the DSN with a current emergency contact list. The DSN Ops Chief shall use this list to provide information on ground system failures and suspected spacecraft problems when the project is not staffed.

Upon declaration, the DSN Ops Chief shall immediately coordinate release of DSN resources required to support the emergency. The DSN Ops Chief will respond to a voice request from the declaring project and coordinate with other users to release or obtain additional resources. Changes to support shall be negotiated and coordinated to ensure that terminating support for other spacecraft does not put another spacecraft or mission in danger. As soon as feasible, the declaring project will follow the voice declaration with a schedule change request in accordance with standard procedures.

The DSN will respond to a declared spacecraft emergency by immediately rearranging the operational schedule and providing the resources required to support the emergency. Conflicting missions will accommodate emergency support requests by expeditiously terminating their activities and relinquishing the required resources. If a resource is supporting a Level-1 critical event, that resource will not be reallocated to emergency support without the explicit approval of the Project Manager or designee. The DSN response time shall not exceed 2 hours, where the response time is defined as the time between the release of the antenna in use and being on-point and ready to begin emergency spacecraft acquisition. The response time specifically excludes the time required for negotiating in-use resources, and for “safing” and terminating support for the on-track spacecraft. The DSN Operations Chief will notify all affected missions.

A declaration of a spacecraft emergency will not be used solely to obtain DSN support that would not be available through the normal scheduling process.

DSN Spacecraft Emergency support shall be limited nominally to 72 hours. If there is a signal detected, the DSN Project Manager along with inputs coordinated via the DSN/Mission Services Planning and Management Program Manager, will determine the length of the emergency. The DSN Ops Chief will negotiate and bring up additional supports as needed for 72 hours. After that time, the project will be expected to use the normal DSN scheduling process. If additional time is required, the project shall notify the DSN Ops Chief as soon as possible to request an extension and the DSN Ops Chief shall work the request with the DSN Ops Manager and other DSN Project management. The project shall also provide status to the DSN Ops Chief, MIM, and DSN Project management regularly (e.g., every 24 hours, as to the current spacecraft status. It is expected that this status shall be brief.



When an outside agency declares a spacecraft emergency and emergency cross support is required, it may only receive support authorized by approved agreements unless otherwise authorized by the DSN Operations Manager.

### **3.10 DSN-MISSION SERVICE INTERFACE VALIDATION**

This section provides DSN requirements and expectations for DSN-to-Mission interface validation testing. Failure to execute these interface validation tests increases the risk of operational issues, and will result in a negative risk assessment by the DSN at the launch or mission event readiness review.

DSN assets will be available to support these interface validation tests, as well as other system tests conducted by missions to validate their ground data systems.

#### **3.10.1 DSN TEST FACILITIES**

The DSN maintains three test facilities:

- Development and Test Facility (DTF-21), near JPL
- Compatibility Test Trailer (CTT-22), a transportable facility
- Merritt Island Launch Facility (MIL-71), located at Kennedy Space Center

The services and capabilities of the DSN test facilities are described in the DSN 810-043 document. It should be noted that none of these facilities can validate Delta-Differential One-way Range (DDOR) services. In addition, only the DTF-21 facility includes a flow of station monitor data or an OLR.

#### **3.10.2 DSN-MISSION RF COMPATIBILITY TESTS**

DSN-Mission Radio Frequency (RF) Compatibility testing occurs pre-launch and validates the spacecraft radio frequency subsystem and its telecommunications capabilities as they interact with DSN RF and data systems. The 814-005 describes the tests performed for RF Compatibility in detail.

RF Compatibility testing is always conducted using a DSN test facility, and typically occurs under one or more of the following conditions, depending on the mission:

- Spacecraft RF subsystem testing at DTF-21, before spacecraft integration
- Spacecraft RF system testing at the spacecraft site, after the spacecraft is integrated, using the CTT-22 facility
- Integrated Spacecraft RF system testing at the Kennedy Space Center (KSC) launch site, using the MIL-71 facility

The DSN **strongly recommends** pre-launch RF compatibility testing as a means to eliminate post-launch anomalies and expensive troubleshooting. **Table 3-4** lists the set of standard compatibility tests for DSN customers.

**Table 3-4. DSN RF Compatibility Tests**

Test	Test Name
	<b>Receiver/Transmitter</b>
RF-0	RF Link Calibration
RF-1	Frequency Stability, Uplink Receiver Threshold and Antenna Gain Control (AGC) Calibration
RF-2	Uplink Receiver Acquisition and Tracking
RF-3	Uplink Receiver Tracking Range
RF-4	Downlink Transmitter RF Output Power
RF-5	Downlink RF Spectrum Analysis
RF-6	Downlink Receiver Threshold
	<b>Range</b>
RNG-1	DSN Station Range Delay
RNG-2	Range Delay and Polarity
	<b>Telemetry</b>
TLM-2	Telemetry Performance
	<b>Command</b>
CMD-1	Command Performance
	<b>End-To-End Test</b>
	Telemetry and Command System Data Flow Test

*If a mission does not accommodate the standard set of RF compatibility tests, the DSN will request a written waiver from the Project Manager stating that DSN will not be held responsible for potential loss of mission objectives, or the mission itself, due to incompatibility.*

The mission may also conduct an End-To-End (E2E) data flow test when CTT-22 is connected to the spacecraft telecommunications system at their local site. However, mission data flow tests using the CTT-22 will not be performed in parallel with DSN RF compatibility testing. The mission may schedule additional days for the CTT-22 to perform E2E data flow tests only after the RF compatibility tests are successfully completed. It should be understood that the CTT-22 is not operated using standard DSN operational procedures, and is not staffed by operational personnel. Rather, the CTT-22 is staffed by DSN test engineers. Therefore, tests conducted with this facility may not reflect operational interfaces and capabilities of the stations.

The MIM leads the planning and coordination of the RF Compatibility tests, and serves as point of contact for mission questions and concerns regarding test planning.

The mission is responsible for delivering a Spacecraft RF Compatibility Test Plan to the MIM that describes the spacecraft telecommunication subsystem, and the tests required to validate the spacecraft to DSN interface for: 1) transmission and reception of the spacecraft RF signals, and 2) that the DSN can properly process data generated by the spacecraft in all the planned operational modes. The mission is also responsible for completing the DSN RF Compatibility Test Checklist provided by the MIM. When the CTT-22 is being used, providing the necessary interfaces for it, such as power, network connectivity, parking space, etc., is also the mission's responsibility.

The DSN O&M contractor test team is responsible for using the mission's Spacecraft RF Compatibility Test Plan to generate the DSN Compatibility Test Procedure. The O&M contractor test team conducts the test and makes the measurements to verify predicted link performance and to validate DSN compatibility. The O&M contractor test team is also responsible for documenting the test results in the DSN Compatibility Test Report.

### **3.10.3 STATION DATA FLOW TESTS**

Station data flow tests validate a subset of the many possible spacecraft modes and DSN station configurations. These tests can be combined with other mission GDS tests. The DSN expects the mission to complete the following minimum set of pre-launch station data flow tests:

- CMD: Validate uplink data rate change at one supporting station
- CMD: Validate the ability to perform command bind and data flow with one supporting station at each complex
- TLM: Validate Quality of Service requirements (latency, completeness, continuity) for each unique telemetry mode (each rate/code/modulation configuration), including safe mode, at one station at each complex
- SPS: Validate predict generation at one supporting station

Additionally, station data flow tests validate the service interfaces between the DSN and the Mission Operations Center (MOC). The DSN expects the mission to complete the following pre-launch station data flow tests:

- Using a DSN station and the MOC, validate the interface to each unique operations and data service to be used by the mission

The MIM can assist the mission in understanding the station data flow test expectations.

### **3.10.4 OPERATIONAL READINESS TESTS**

Mission Operational Readiness Tests (ORTs) are planned and conducted by the Mission, and demonstrate that all elements of the ground segment (hardware, software, people, procedures, and facilities) work together to accomplish planned mission activities. In addition, ORTs may be used to validate the DSN-Mission E2E ground system data flows and operational interfaces with the mission. The DSN participates in ORTs to execute mission-specific configurations and operations processes as part of readiness verification for mission critical events.

*The DSN expects to be scheduled as a participant in at least one Mission ORT for each mission critical event.*

### **3.10.5 PROJECT INTERFACE TESTS AND STATION RETURN-TO-SERVICE DEMONSTRATIONS**

Missions are expected to participate in post-launch DSN Project Interface Tests (PITs) and Station Return-To-Service Demonstrations to test and validate new implementations, upgrades, and changes to DSN-mission system interfaces. The DSN is responsible for conducting these tests, with mission participation. It is expected that the mission will report any interface discrepancies observed during the test to the DSN.

### 3.10.6 TEST DATA INPUTS

Missions are responsible for providing binary simulation (SIM) files created from the spacecraft's telemetry to support testing of DSN telemetry processing and data delivery systems. To make these files effective for testing and training, a mission should record telemetry with all coding schemes expected during nominal operations, safe mode conditions, and special critical support operations.

The spacecraft simulation files are delivered to the Network Operations Project Engineer (NOPE) for installation on DSN test equipment for input into the station telemetry equipment. All coding, except Non-Return-to-Zero (NRZ-L), S, M, and Bi-Phase L, must be contained in the file, or special arrangements must be made to have the test equipment encode the data.

When delivering a binary file, there should be an additional text file that describes the data contents, including the following information:

- Project name
- Filename: (eight characters)
- File Size (Bytes)
- Number of frames
- Frame sync word: (in Hex)
- Frame size: (in Bytes)
- Code type: (NRZ or Bi-Phase)
- Bit rates: (with R-S if applicable)
- Symbol rates
- Coding included using Consultative Committee for Space Data System (CCSDS) formats
- Virtual Channel IDs (VCIDs) contained in the file
- Any errors in the data

The spacecraft simulation files are sent by the mission user to the NOPE via secure file transfer, such as that provided by the JPL Large File Transfer (LFT) at <https://lft.jpl.nasa.gov/>. The NOPE will assist the mission in using the JPL LFT server as required. The NOPE will install the delivered files on the DSN SIM file server.

The mission is responsible for the integrity of the binary files delivered to the NOPE. The NOPE will test newly delivered SIM files to ensure that the files satisfy DSN requirements and will notify the mission after testing is complete and the files are available for use.

### 3.11 DSN-MISSION REVIEWS

In addition to testing and other verification and validation activities, the DSN conducts a series of reviews that are intended to review the DSN's readiness to provide various aspects of the services.

The DSN invites the mission's participation in the following reviews, for which the MIM is the responsible individual.

### **3.11.1 MISSION REVIEW OF DSN INITIAL ACQUISITION PLAN**

This is an informal review of the Initial Acquisition Plan (IAP), held prior to and in preparation for, the Mission Event Readiness Review (MERR). The purpose of this review is to gather mission comments on the DSN IAP. The IAP identifies the configuration to support initial acquisition at the DSN station, and provides data link analysis and margins based on the spacecraft's configuration.

### **3.11.2 MISSION REVIEW OF DSN RISK ASSESSMENT FOR CRITICAL EVENTS**

This is an informal review conducted approximately one to two months prior to the critical event. The purpose of this review is to gather mission comments on the DSN risk assessment for the critical event. The results of this review are reported at the MERR.

### **3.11.3 MISSION EVENT READINESS REVIEW (MERR)**

The purpose of the Mission Event Readiness Review is to assess the operational readiness of the DSN for a critical mission event, and to report the results to the DSN Project Manager. This is a formal DSN review with the project or mission manager serving on the review board. The review highlights the DSN's supporting elements, system configuration, mission-related testing, training, problems encountered, and corrective actions. Cross-support services, if any, are included. The MERR is held at least 30 days prior to the critical event.

### **3.11.4 LEVEL TWO STATUS REVIEW (L2SR)**

The purpose of the L2SR is to assess the operational readiness of the DSN for a critical mission event Level 2, and to report the results to the DSN Project Manager. This is a formal DSN review with the project or mission manager serving on the review board. The review highlights the DSN's supporting elements, system configuration, mission-related testing, training, problems encountered, and corrective actions. Cross-support services, if any, are included. The L2SR is held at least 30 days prior to the critical event.

### **3.11.5 SMALLSAT READINESS REVIEW (SRR)**

The purpose of the SRR is to assess the operational readiness of the DSN for a critical mission event usually Level 3, and to report the results to the DSN Project Manager. This is a formal DSN review with the project or mission manager serving on the review board. The review highlights the DSN's supporting elements, system configuration, mission-related testing, training, problems encountered, and corrective actions. Cross-support services, if any, are included. The SRR is held at least 30 days prior to the critical event.

## **3.12 DSN DISCREPANCY REPORTING PROCESS**

This section establishes the DSN policy for identifying, reporting, investigating, and closing discrepancies that occur in the DSN while providing support services to mission customers. A discrepancy is any condition that negatively impacts the quantity or quality of committed data or service to a scheduled DSN customer or to an internal DSN process. In addition, problems experienced during the pre-track preparation period of an activity may also be recorded.

A Discrepancy Reporting Management System (DRMS) is maintained to provide information for performance analysis, data accountability, and the generation of reports for engineering, operations, maintenance, and management personnel.

All DSN and mission customers are considered observers and therefore responsible for reporting discrepancies. The requirements for reporting discrepancies under this policy apply to real-time support and non-real-time support. Discrepancies that are observed under any of the following circumstances are reportable:

- Failure of a committed resource to support a scheduled activity.
- Interruption to committed support, services, or data committed by the DSN and provided by a DSN facility.
- Nonstandard performance of a committed resource, which results in degraded data quality or service.
- Failure of a committed resource to support a nonscheduled activity such as playback, post-processing, or generation and distribution of support data products.
- Interruption to committed support, services, or data committed by the DSN and provided by a non-DSN facility.
- Failures of Research and Development (R&D) hardware or software when they are providing committed support.

When a discrepancy occurs during real time, the mission representative will request a Discrepancy Report (DR) to be opened by the DSCC Station Link Control Operator (LCO) or by the DSOC team as appropriate. If a discrepancy is discovered after the completion of real-time operations and station release, the mission representative will request a DR from the DSN Ops Chief or NOPE. The Ops Chief will open a DR based on the mission report.

Discrepancy reports may be tracked by mission personnel by referring to the MIM.

**A. APPENDIX A: ACRONYMS AND ABBREVIATIONS**

ATLO	Assembly, Test, and Launch Operations
BOA	Beginning of Activity
BOT	Beginning of Track
BWG	Beam Wave Guide
CCSDS	Consultative Committee for Space Data Systems
CDR	Critical Design Review
CDSCC	Canberra DSCC
CEP	Critical Event Planner
CMD	Command Subsystem
CIMO	Customer Interface Management Office (910)
CTT	Compatibility Test Trailer
DCD	Data Capture and Delivery Subsystem
DDOR	Delta Differential One-way Range
DRMS	Discrepancy Reporting Management System
DSA	DSN Service Agreement
DSCC	DSN Deep Space Communication(s) Complex
DSN	Deep Space Network
DSOC	Deep Space Operations Center (JPL Pasadena)
DSOT	Data System Operations Team (call sign is Data Control)
DSS	Deep Space Station (antenna)
DTF	Development and Test Facility
DTT	Downlink Tracking and Telemetry Subsystem
ECC	Emergency Control Center
E2E	End-to-End Data Flow
GDS	Ground Data System
GDSCC	Goldstone DSCC
GSCID	Global Spacecraft Identifier (CCSDS)
GSFC	Goddard Space Flight Center
GSSR	Goldstone Solar System Radar
IND	Interplanetary Network Directorate
JPL	Jet Propulsion Laboratory
KSC	Kennedy Space Center
LCO	Link Control Operator
LFT	Large File Transfer
MDSCC	Madrid DSCC
MERR	Mission Event Readiness Review
MIM	Mission Interface Manager
MOC	Mission Operations Center
MSA	Mission Support Area
MSPA	Multiple Spacecraft Per Antenna
MSTA	Mission Services Training Activities
NASA	National Aeronautics and Space Administration
NMC	Network Monitor and Control Subsystem
NOA	Network Operations Analyst
NOP	Network Operations Plan
NOPE	Network Operations Project Engineer
NRZ	Non-Return-to-Zero

NSOE	Nominal Sequence of Events
O&M	Operations and Maintenance
OICD	Operations Interface Control Document
ORT	Operations Readiness Test
PDR	Preliminary Design Review
PDSE	Project Data System Engineer
PIT	Project Interface Test
PSOE	Pass Sequence of Events
RF	Radio Frequency
RMDC	Radiometric Data Conditioning Software
ROC	Remote Operations Center
SCID	Spacecraft Identifier for ground services
SDP	Support Data Package
SFDU	Standard Formatted Data Unit
SIM	Simulation
SLE	Space Link Extension (CCSDS)
SOP	Standard Operations Procedure
SPC	Signal Processing Center
SPK	Spacecraft-Planet Kernel
SPS	Service Preparation Subsystem
TBD	To Be Determined
TC	Telecommand
TCM	Trajectory Correction Maneuver
TDM	Tracking Data Message (CCSDS)
TLM	Telemetry Data
TRK	Tracking Data
TTC	Tracking, Telemetry and Command
ULP	User Loading Profile
UTC	Universal Time Coordinates
VLBI	Very Long Baseline Interferometry
VOCA	Voice Operational Communications Assembly



## **B. APPENDIX B: DSN AND MISSION REAL-TIME OPERATIONS INTERFACE**

### **B.1 DSN Operations Overview**

The Deep Space Network (DSN) is an international network of antennas and supporting infrastructure that supports interplanetary spacecraft missions and radio and radar astronomy observations for the exploration of the solar system and the universe. The network also supports selected Earth-orbiting missions.

The specific assets and facilities that comprise the DSN are subject to change throughout the mission lifetime. The DSN includes three deep-space communications complexes located around the world: at Goldstone, California (GDSCC); Madrid, Spain (MDSCC); and Canberra, Australia (CDSCC). The antennas and ground data processing and delivery systems make it possible to acquire telemetry data from spacecraft, transmit commands to spacecraft, track spacecraft position and velocity, and perform ground-based scientific observations. Each DSN communications complex has a Signal Processing Center (SPC) and a number of antennas, including one 70 m antenna and at least three 34 m Beam Wave Guide (BWG) antennas. NOTE – the sole HEF 34M antenna is DSS65 and will remain active until ~2021.

Telemetry distribution and storage functionality for the DSN is implemented via the Deep Space Operations Center (DSOC) located at the Jet Propulsion Laboratory (JPL). This facility provides TTC data distribution and storage services and is the main center for ground voice/data communication.

The sites for real-time operations support during the service execution phase include the Deep Space Communications Complex (DSCC) and the DSN Deep Space Operations Center (DSOC), located at JPL in Pasadena. The real-time and offline data delivery interface for the missions is from the DSOC as shown in **Figure B-1**.

For nominal operational tracks, only the DSCC and DSOC are staffed with a DSCC staffed only during daylight prime shift hours during the Follow the Sun (FtS) era which started November 2017. During mission-critical activities, the DSN will support the track with additional personnel in a situational manner to meet the response requirements negotiated for the support. Those personnel will be located at the appropriate DSN locations including the Remote Operations Center (ROC) (near JPL) for monitoring the support.

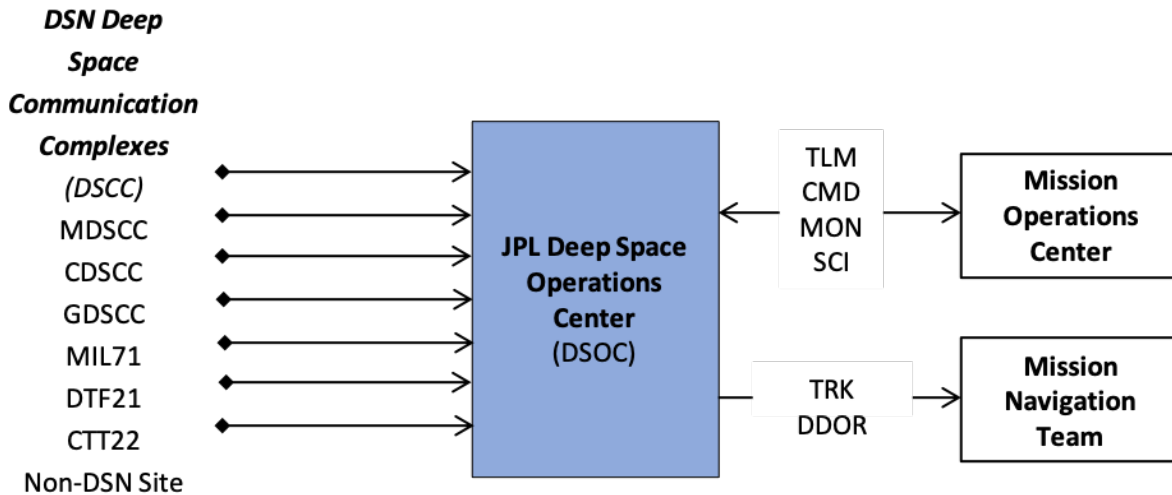

Figure B-1. DSOC End-to-End Data Delivery Overview

## B.2 Real-Time DSN Space Communications Complex (DSCC) Operations

The real-time operations of a station, called a Deep Space Station (DSS), are conducted by a Station Link Control Operator (LCO). The LCO's Call Sign is the Station Identifier, DSS-##. The LCO will communicate with the mission controller during the pass. Typical pass support activities are accomplished in three phases: setup time, tracking (or real-time), and teardown time. Pre-track activities occur during setup from Beginning of Activity (BOA) to Beginning of Track (BOT) as specified in the 7-day schedule. During this period, the station will configure in accordance with the predicted Pass Sequence of Events (PSOE) or, alternatively, in accordance with a pre-track briefing given by the mission. The PSOE utilized by the LCO is derived from the Nominal SOE (NSOE) specified by the mission in the schedule or from a DSN Keyword File (DKF) delivered by the mission for the pass. Any rate changes planned during the track are to be included in the NSOE/DKF. A mission pre-track briefing includes any spacecraft configuration or status information that may affect the track that is not reflected in the SOE, or that has a potential for deviating from the SOE. The briefing should not repeat information that is properly represented in the SOE. It also provides an opportunity for station personnel to raise any questions or concerns regarding support requirements.

The DSN station will nominally configure to support the activities that are planned during the track, as identified in the PSOE. The duration of the setup is defined by this set of activities and enforced by the DSN scheduling process. Because the station will only be configured and calibrated with appropriate subsystems assigned for the planned activities, some real-time changes may not be accommodated. For example, if the track is not planned to provide an uplink service, the station will not be configured to support uplink.

Typically, 15 minutes are allocated for teardown activities to allow the LCO to dissolve the link and begin preparations for the next scheduled support.

Prior to a critical elevated support pass, the mission will provide a pre-track briefing to confirm the planned activities and to brief the station on any deltas to the SOE.

### **B.2.1 Internet Sources for Real-Time DSN Station Status**

The following information can be obtained from internet sources and does not require real-time requests to the station link operator.

General DSN Operational Status

<https://eyes.nasa.gov/dsn/>

### **B.2.2 DSN Complex Weather Data**

If a mission needs real-time weather reports for the DSN locations, there are many available web sites. Here are some example web sites:

Madrid MDSCC Weather Report:

<https://www.accuweather.com/en/es/robledo-de-chavela/305924/weather-forecast/305924>

Goldstone GDSCC Weather Report:

<https://www.accuweather.com/en/us/fort-irwin-ca/92310/weather-forecast/342353>

Canberra CDSCC Weather Report:

<https://www.accuweather.com/en/au/tidbinbilla/12209/weather-forecast/12209>

### **B.2.3 Real-Time Schedule Changes**

The publication of the 7-Day Operations Schedule represents a commitment of DSN resources to the scheduled users. This commitment is not altered without the consent of the scheduled user except during spacecraft emergencies. Any real-time schedule changes are coordinated through the DSN Ops Chief.

## **B.3 DSN Deep Space Operations Center (DSOC) at JPL**

The Deep Space Operations Center (DSOC), located at JPL, provides real-time support and is staffed 24 hours per day, 7 days per week. The following defines the current configuration of the teams that support real-time operations at DSOC although this is subject to change throughout the life of the mission. The DSOC operations teams include:

1. Network Operations Control Team (NOCT):
  - a. Call sign: Ops Chief - Operations Chief manages the Network Operations Control Team (NOCT), directs DSN problem resolution and failure recovery, and manages Network resources.
  - b. Call sign: Comm Chief - Communications Chief monitors communication lines and coordinates data or voice problems.
  - c. Call sign: TSS - Tracking Support Specialist monitors tracking passes and ensures integrity of Network configurations, assists in troubleshooting Network problems, and assists with

generation and delivery of support products. The TSS acts as the technical advisor for L3 supports when the NOPE is not present.

2. Data System Operations Team (DSOT):
  - a. Call sign: Data Control
  - b. DSOT operates the TTC Central Data System to capture and deliver spacecraft telemetry, tracking, and station monitor data to missions. This includes operations of DSN Telemetry, Tracking, and Monitor data capture, processing, and delivery to the mission.
3. Radio Metric Data Conditioning Team (RMDC Team):
  - a. No call sign, offline support position
  - b. The RMDC Team supports validation and delivery of radiometric data product files to navigators and radio science team members on request. The team works only normal business hours, except for special support arrangements for critical activities. However, there is also RMDC software that conditions and generates the tracking data products and executes autonomously 24 hours per day, 7 days per week. DSOT monitors these autonomous functions. Functions that require manual intervention by the RMDC team will be executed on the first business day after each track.

The teams ensure that the DSN meets real-time, scheduled commitments and responds to emergency situations across the network. The Ops Chief provides inter-complex coordination and directs schedule conflict resolution, resource allocation, and failure recovery based on immediate support priorities and available DSN resources. The normal interface for operational support at the stations is between the mission controller and the Link Control Operator at the DSCC. When necessary, the Ops Chief and the TSS assists in problem resolution. For real-time TTC or science data delivery problems, the normal interfaces for operational support at DSOC are the DSN Comm Chief for voice/data communication issues and the Data Control Operator (Data System Operations Team, DSOT) for telemetry, monitor and tracking data delivery issues.

For critical L1/L2 events, the NOPE monitors network operations and authorizes any change in station configuration. The DSN Ops Chief responds to all mission polls for DSN readiness to support the critical activities. If a station is unable to provide committed data or meet expected performance levels because of equipment failure or degradation, the Ops Chief provides this information to the project and a DR is opened on the problem.

#### **B.4 DSN Real-Time Operations Points of Contact**

The real-time contact information for DSOC teams is provided below. The DSN-<Mission> OICD will contain mission-specific points of contact and voice call signs. All support communication is to be via DSN voice operations (VOCA) interfaces as described above. The telephone should be used only in the event that a VOCA interface is not available. During critical activities, additional facilities or workstations may be added to the network in support of the activity.

**Table B-1.** DSN General Points of Contact for Mission Support

<b>Position</b>	<b>Telephone Location</b>	<b>Call Sign</b>
DSN Operations Chief (Ops Chief) or Tracking Support Specialist (TSS)	(818) 393-7990 JPL DSOC	Ops Chief TSS
DSN Operations Chief (comm issues)	(818) 393-5800	Ops Chief
SCAMA Line (VOCA patch, emergency use only)	(818) 393-0100 JPL DSOC	
Data System Operations Control (Data Control)	(818) 393-7907 JPL DSOC	Data Control
DSS Station Link Control Operator	VOCA DSCC SPC	DSS-##
NOPE (For Elevated Supports only)	VOCA Remote Ops Center (ROC) DSN O&M	NOPE

The contact information for special requests is described in the table below:

**Table B-2.** DSN-Mission Points of Contact for Special Requests

<b>Category</b>	<b>Mission Rep</b>	<b>DSN Contact</b>
Declaration of Spacecraft Emergency	Flight Project Manager or Designee	Ops Chief (Real-Time)
Notification for release of station time for spacecraft emergency	Mission Manager or Designee	Ops Chief
Respond to mission poll for DSN readiness during L1 critical event	Mission Manager or Designee	Ops Chief
Mission contact for near real-time notification of ground support issues	(DSN Emergency Notification List)	Ops Chief
Approval of Mission Requests for JPL User Accounts	Mission Manager	MIM

## Notification List

Contact the document owner regarding additions, deletions, or changes to this list. Copies of this document are available in ePDMS: <https://plmpdms.jpl.nasa.gov/awc/#/showGateway>

<b>Electronic Notification</b>	
GDSCC Documentation	dl-jgld-documentation@gdsc.nasa.gov
Arnold, Brad	Bradford.W.Arnold@jpl.nasa.gov
Arroyo, Belinda	belinda.arroyo@jpl.nasa.gov
Asmar, Sami	sami.w.asmar@jpl.nasa.gov
Berner, Jeff B	jeff.b.berner@jpl.nasa.gov
Giovannoni, Brian	Brian.J.Giovannoni@jpl.nasa.gov
Levesque, Michael E.	levesque@jpl.nasa.gov
Mission Interface Managers	mim@jpl.nasa.gov
Navarro, Robert	Robert.Navarro@jpl.nasa.gov
Sanders, Felicia	felicia.a.sanders@jpl.nasa.gov
<b>DSN Overseas Personnel</b>	
CDSCC Documentation	cdsc-documentation@cdsc.nasa.gov
MDSCC Documentation	mdsc-documentation@mdsc.nasa.gov